

WASHBURN UNIVERSITY MABEE LIBRARY RENOVATION

GRAPHIC SYMBOLS

EXPANSION JOINT
CONTROL JOINT
FLOOR COVERING CHANGE
SPOT ELEVATIONS IN FEET AND INCHES (OR ON SITE PLAN IN FEET AND DECIMALS)
NEW DOOR
EXISTING DOOR
DOOR MARK - REFERENCE DOOR AND FRAME SCHEDULE
LOCATION OF SYMBOL ON PAIR OF DOORS INDICATES THE ACTIVE LEAF
PLAN NOTES
SECTION MARK:
 1 = DETAIL NUMBER
 A101 = SHEET NUMBER
INTERIOR ELEVATION MARKER:
 A202 = SHEET NUMBER
BUILDING ELEVATION MARKER:
 A201 = SHEET NUMBER
DETAIL MARKS:
 1 = DETAIL NUMBER
 A101 = SHEET NUMBER
ELEVATION MARK IN FEET AND INCHES
STEEL FRAME MARK - REFERENCE FRAME ELEVATIONS
ALUMINUM FRAME MARK - REFERENCE FRAME ELEVATIONS
GLASS TYPE - REFERENCE GLASS SCHEDULE ON SHEET A501
PARTITION MARK - REFERENCE PARTITION SCHEDULE (1) INDICATES FIRE RATING OF WALL IN HOURS
TB - 4" MB - 6"
PS - 8" IWB - 6"
MASONRY CONTROL JOINT FROM BEARING TO TOP OF WALL
MASONRY CONTROL JOINT FROM BEARING TO TOP OF WALL, PROVIDE ON BOTH SIDES OF WALL
MASONRY CONTROL JOINT FROM LINTEL BEARING TO TOP OF WALL OR BOND BEAM
MASONRY CONTROL JOINT FROM BEARING TO TOP OF WALL, PROVIDE ON BOTH SIDES OF WALL
MASONRY CONTROL JOINT FROM LINTEL BEARING TO TOP OF WALL OR BOND BEAM
MASONRY CONTROL JOINT FROM BEARING TO TOP OF WALL, PROVIDE ON BOTH SIDES OF WALL
MASONRY DUMMY CONTROL JOINT. LOCATE SIMILAR TO CONTROL JOINT NOTE ABOVE.
CASEWORK DESIGNATION: NUMBER INDICATES UNIT NUMBER SHOWN ON CASEWORK AXONS. REFERENCE SPECIFICATIONS.
EQUIPMENT OR FURNISHINGS SHOWN ON FLOOR PLANS. INDICATES FURNISHINGS BY OWNER (N.I.C.) ON FIXED EQUIPMENT PLANS
SIGN TYPE AND LOCATION SYMBOL
FLOOR DRAIN (ELEVATION IN FEET AND INCHES WHERE INDICATED)
MOP/SANITIZER SINK
WATERCLOSET, URINAL, LAVATORY (RESPECTIVELY)
DRINKING FOUNTAIN - REFERENCE PLUMBING
FEC: FIRE EXTINGUISHER CABINET
COLUMN GRID NUMBERS AND/OR LETTERS

NOTE: REF. SITE PLAN LEGEND, ROOF PLAN LEGEND AND CEILING PLAN LEGEND FOR ADDITIONAL NOTES AND LEGENDS.

ABBREVIATIONS

NOTE: REFER TO SPECIFICATIONS FOR ADDITIONAL ABBREVIATIONS OF REFERENCED STANDARDS, AS WELL AS CONSTRUCTION SPECIFICATION INSTITUTE, UNIFORM DRAWINGS SYSTEM, REGULATORY AGENCIES, ASSOCIATIONS AND OTHERS.

AB	ANCHOR BOLT	MAS	MASONRY
ABV	ABOVE	MATL	MATERIAL
ADJ	ADJACENT	MAX	MAXIMUM
AFF	ABOVE FINISH FLOOR	MC	MECHANICAL CONTRACTOR
AHU	AIR HANDLING UNIT	MDO	MEDIUM DENSITY OVERLAY
ALT	ALTERNATE	MECH	MECHANICAL MECHANISM
ALUM	ALUMINUM	MFR	MANUFACTURER
ANCH	ANCHOR	MIN	MINIMUM
ANG	ANGLE	MISC	MISCELLANEOUS
AR	ABUSE-RESISTANT	MO	MASONRY OPENING
ARCH	ARCHITECTURAL	MTL	METAL
AT	AVERAGE "R" FACTOR	NA	NORTH
AVC R	AVERAGE "R" FACTOR	N	NOT APPLICABLE
BD	BOARD	NIC	NOT IN CONTRACT
BLDG	BUILDING	NO #	NOMINAL
BM	BEAM, BENCH MARK	NOM	NOT TO SCALE
BRG	BEARING	NTS	NORMAL WEIGHT CMU
BTM	BOTTOM	NWCMU	NWCMU
BUR	BUILT-UP ROOFING	OA	OVERALL
CABT	CABINET	OC	OCCUPANT OCCUPANCY
CH	COAT HOOK	OC(S)	ON CENTER (STAGGERED)
CP	CAST-IN-PLACE	OD	OVERFLOW DRAIN
CJ	CONTROL JOINT	OP	OPERATING/OPERABLE
C	CENTER LINE	OPNG	OPENING
CG	CEILING	Q	QUANTITY
CMU	CONCRETE MASONRY UNIT	PARTN	PARTITION
CMT	CERAMIC MOSAIC TILE	PB	PARTICLE BOARD
CMP	CORRUGATED METAL PIPE	PC	PORTLAND CEMENT, PIECE
CO	CLEAN OUT	PERM	PERMETER
COL	COLUMN	PLAM	PLASTIC LAMINATE
COND	CONCRETE CONDITION	PNL	PANEL
CONC	CONCRETE	PWD	PLYWOOD
CONST	CONTINUOUS, CONTINUE	PSF	POUNDS PER SQUARE FOOT
COAT	CONTINUOUS, CONTINUE	PSI	POUNDS PER SQUARE INCH
DBL	DOUBLE	PVMT	PAVEMENT
DF	DRINKING FOUNTAIN	QTY	QUANTITY
DIA	DIAMETER	QT	QUARRY TILE
DIM	DIMENSION	R	RADIUS
DR	DOOR	RA	RETURN AIR
DWG(S)	DRAWING(S)	RCP	REINFORCED CONCRETE PIPE
DS(O)	DOWNSPOUT (OUTLET)	RD	ROOF DRAIN
DTL	DETAIL	REF	REFER TO REFERENCE
E	EAST	REFL	REFLECTED
EA	EACH	REIN	REINFORCING, REINFORCED
EJ	EXPANSION JOINT	REQD	REQUIRED
ELEC	ELECTRICAL	REV	REVERSED, REVISED
EL	ELEVATION	RJ	RUSTICATION JOINT
ENCL	ENCLOSURE	RMS	ROOM
EQ	EQUAL	RO	ROUGH OPENING
EQUIP	EQUIPMENT	RTU	ROOF TOP UNIT
EXP	EXPANSION	S	SOUTH
EXT	EXTERIOR, EXTERNAL	SAN	SANITARY
EXIST, EX	EXISTING	SC	SAWTOOTH
FD	FLOOR DRAIN	SD	SOAP DISPENSER
FE	FIRE EXTINGUISHER	SECT	SECTION
FEC	FIRE EXTINGUISHER CABINET	SF	SQUARE FOOT
FHC	FIRE HOSE CABINET	SFCMU	SPLIT FACE CMU
FIN	FINISH	SHT	SHEET
FLWR	FLOWLINE	SIM	SIMILAR
FLNG	FLOORING	SND	SANITARY NAPKIN DISPENSER & DISPOSER
FND	FOUNDATION	SPEC(S)	SPECIFICATION(S)
FOS	FACE OF STRUCTURE	SQ	SQUARE
FR	FIRE RATED, FIRE RESISTIVE	SS	STAINLESS STEEL
FS	FLOOR SINK, FOOD SERVICE	STD	STANDARD
FT	FEET OR FOOT	STL	STEEL
FV	FIELD VERIFY	STRUCT	STRUCTURAL, STRUCTURE
GA	GAUZE	SUSP	SUSPENSION
GALV	GALVANIZED	SYMM	SYMMETRICAL
GC	GENERAL CONTRACTOR	TB	TACKBOARD
GEN	GENERAL	TD	TOWEL DISPENSER & DISPOSER (PAPER), OR TRENCH DRAIN TONGUE AND GROOVE
GL	GALVANIZED IRON	TEMP	TEMPERED, TEMPORARY
GLASS	GLASS	TEXT	TEXTURED
GYP	GYPSONUM	TGT	TARGET
HC	HANDICAPPED (ACCESSIBLE)	TP	TOWEL PAPER DISPENSER
HD	HAND DRYER	TR	TRANSFORMER, TRANSITION
HDW	HARDWARE	TYP	TYPICAL
HM	HOLLOW METAL	UNO	UNLESS NOTED OTHERWISE
HT	HEIGHT	US	URINAL SCREEN
HORIZ	HORIZONTAL, HORIZONTALLY	VCT	VINYL COMPOSITION TILE
HPL	HIGH PRESSURE LAMINATE	VERT	VERTICAL, VERTICALLY
HR	HOUR	VVW	VINYL WALL COVERING
HVAC	HEATING VENTILATING & AIR CONDITIONING	W	WEST
ID	INSIDE DIAMETER	WC	WATER CLOSET
INSUL	INSULATION	WD	WOOD
INT	INTERIOR	WDP	WINDOW
IWB	INTERACTIVE WHITE BOARD	W/O	WITH OUT
JB	JUNCTION BOX	WO	WHERE OCCURS
J(S)	JOINT(S)	WT	WEIGHT
LT WT	LIGHTWEIGHT	WPG	WATERPROOFING
LT	LIGHT		
LTWC	LIGHTWEIGHT CONCRETE		
MASONRY UNIT	MASONRY UNIT		

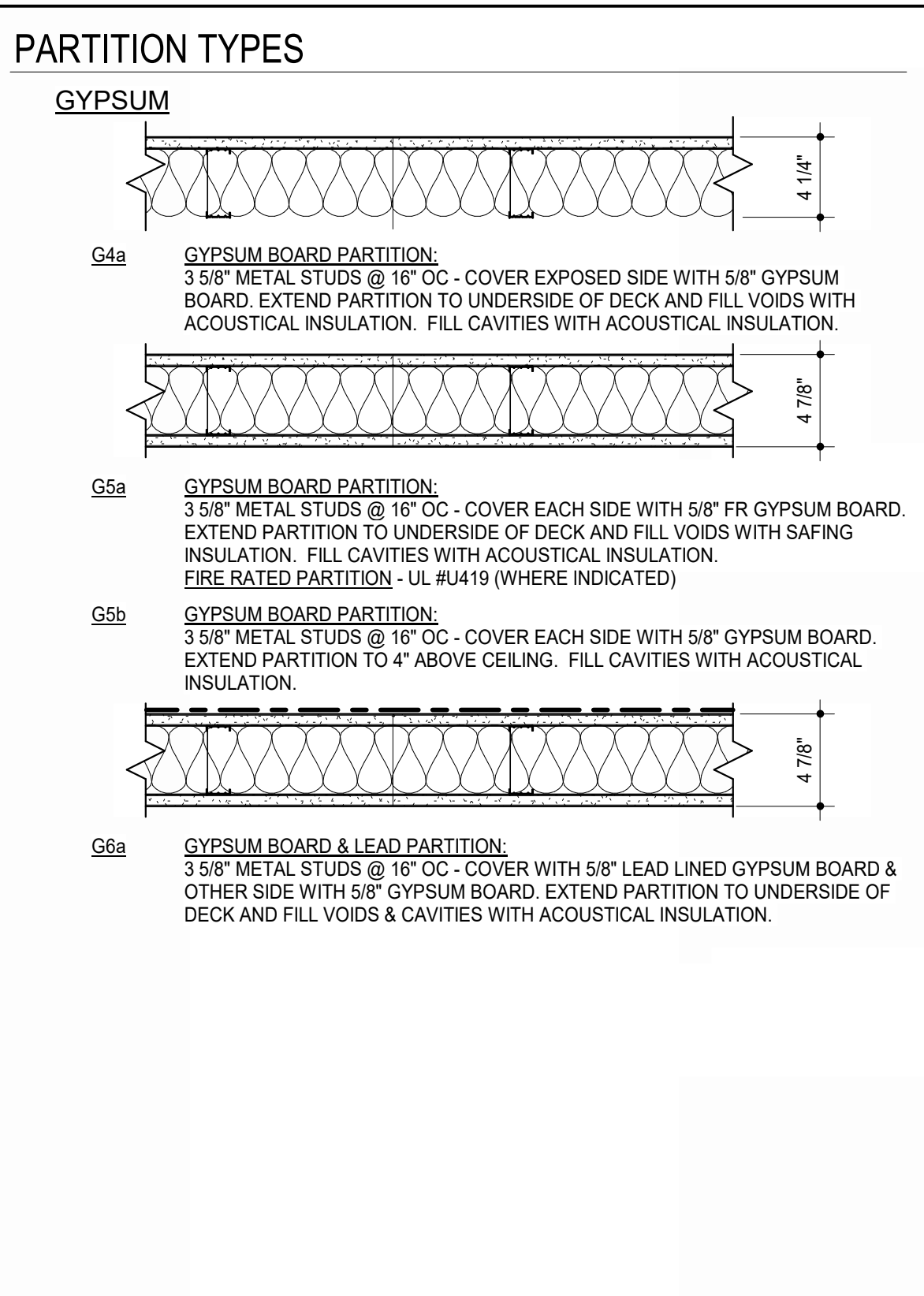

- ### PARTITION SCHEDULE NOTES
- #### GYPSONUM BOARD GENERAL NOTES
- UNLESS NOTED OTHERWISE, EXTEND GYPSONUM BOARD TO UNDERSIDE OF STRUCTURAL DECK ABOVE.
 - REFER TO SPECIFICATIONS SECTIONS 054000 AND 092216 FOR ADDITIONAL REQUIREMENTS.
 - UNLESS NOTED OTHERWISE, PROVIDE 4" ACOUSTICAL INSULATION IN CAVITIES OF ALL PARTITIONS.
 - FRAME AROUND DUCTWORK, BACK BRACE AS REQUIRED FOR STABILITY.
 - REFER TO HOLLOW METAL FRAME DETAILS FOR ADDITIONAL DETAIL REQUIREMENTS.
 - EXTEND STUDS TO TOP RUNNER ATTACHED TO STRUCTURE ABOVE, OR BACK BRACE TO STRUCTURE AS NECESSARY TO FULLY STABILIZE THE PARTITIONS.
 - REFER TO COLUMN DETAILS FOR ADDITIONAL DETAIL REQUIREMENTS.
 - REFER TO FINISH SCHEDULE FOR WALL FINISH.
 - ALL PENETRATIONS THROUGH GYPSONUM BOARD PARTITIONS EXPOSED TO VIEW WILL BE TRIMMED NEAT AND TRUE AND SEALED.
 - WHEN PARTITION EXTENDS TO STEEL BEAM ABOVE, FILL VOIDS BETWEEN DECK AND TOP OF STEEL BEAM WITH SAFING INSULATION.
 - WHERE JOISTS PENETRATE PARTITIONS EXTENDING TO STRUCTURE ABOVE, HOLD PARTITIONS 3/4" CLEAR OF JOIST TO ALLOW FOR DEFLECTION AND FILL VOID WITH SAFING INSULATION.



KEYNOTES

NOTE: KEYNOTES ARE DRAWN FROM A MASTER LIST AND MAY NOT BE SEQUENTIALLY NUMBERED. ISSUES EX-244 OR OTHER INFO FOLLOWING KEYNOTE ON DRAWINGS INDICATES CRITERIA FOR THOSE MATERIALS/LOCATIONS WHICH MAY DIFFER FROM THE STD. MATERIAL SPECIFIED.

033000	-1 CONCRETE	062000	-1 GYPSONUM BOARD (*)
	-2 CONCRETE FLOOR SLAB		-2 FIRE RATED GYPSONUM BOARD (*)
	-3 VAPOR BARRIER		-3 CERAMIC TILE BACKER
	-4 WELDED WIRE FABRIC		-4 METAL SUSPENSION SYSTEM
050000	-1 STEEL ANGLE		-5 ACOUSTICAL SEALANT
	-2 STEEL ANGLE		-6 ACOUSTICAL INSULATION(*)
	-3 STEEL PLATE		-7 METAL EDGE TRIM
061000	-2 2X WOOD BLOCKING (*)		-8 AUXILIARY SUPPORT FRAMING
	-3 PLYWOOD BACKER		-9 HIGH IMPACT GYPSONUM BOARD
064110	-1 PLASTIC-LAMINATE		-10 INTERIOR FINISHING
	-2 FACED ARCHITECTURAL CABINETS	093013	-2 GLAZED WALL TILE (X")
	-3 CABINET LAMINATE		-3 PORCELAIN FLOOR TILE
	-4 PLYWOOD		-4 METAL EDGE STRIP
	-5 3/4" DOOR MOLDING	095113	-1 ACOUSTICAL PANEL (X")
	-6 DOOR HINGE		-2 CEILING SUSPENSION SYSTEM
	-7 DOOR/DRAWER PULL		-3 EDGE MOLD TRIM
	-8 MAGNETIC CATCH		-4 AUXILIARY SUPPORT FRAMING
	-9 DRAWER		-5 RESILIENT WALL BASE
	-10 SHELF SUPPORTS	096513	-2 EDGE STRIP
	-11 COUNTERTOP SUPPORT		-3 RESILIENT SHEET FLOORING
	BRACKET	096519	-1 RESILIENT FLOOR TILE
072100	-4 BUILDING INSULATION - FACED (R)	096513	-1 CARPET TILE
	-5 SILL SEALER	097200	-1 WALL COVERING
	-6 SAFING INSULATION	099123	-1 INTERIOR PAINT
076200	-1 SHEET METAL FLASHING AND COUNTERFLASHING	101100	-1 MARKERBOARD
076200	-1 JOINT SEALANT - RAKE	101400	-1 DIMENSIONAL LETTER SIGNAGE
	-2 JOINT FILLER	102113.17.1	-1 PHENOLIC CORE TOILET COMPARTMENT
	-3 GASKET	102600	-1 CORNER GUARD
	-4 BACKER ROD		-2 RRP IMPACT RESISTANT WALLCOVERING
081113	-2 HOLLOW METAL FRAME	102800	-2 TOILET TISSUE DISPENSER
	-3 FRAME ANCHOR		-3 PAPER TOWEL DISPENSER
081410	-1 FLUSH WOOD DOOR		-4 SANITARY NAPKIN DISPOSER
081113	-1 ALUMINUM ENTRANCE DOOR		-7 GRAB BAR
	-2 ALUMINUM STOREFRONT FRAME	104413	-1 DIAPER CHANGING STATION
088000	-1 GLAZING (AS SCHEDULED)	122413	-1 ROLLER WINDOW SHADES
092216	-1 STEEL STUD (*)	123513.13.1	-1 METAL LABORATORY CASEWORK
	-2 STEEL STUD RUNNER (*)	123611.16.1	-1 SOLID SURFACE COUNTERTOP
	-3 FURRING CHANNEL	134000	-1 LEAD LINED OVP. BR.
			-2 LEAD GLASS
			-3 HOLLOW METAL FRAME
			-4 LEAD LINED WOOD DOOR

- ### GENERAL NOTES
- CONTRACTOR SHALL NOTIFY THE ARCHITECT OF ANY DISCREPANCIES BETWEEN SPECIFICATIONS AND DRAWINGS. BETWEEN MULTIPLE SPECIFICATION SECTIONS AND/OR BETWEEN MULTIPLE DRAWINGS. THE ARCHITECT WILL DETERMINE WHICH SHALL GOVERN.
 - CONTRACTOR SHALL VERIFY ALL DIMENSIONS AND CONDITIONS OF THE JOB SITE INCLUDING UTILITIES AND EXISTING STRUCTURES PRIOR TO BEGINNING WORK AND REPORT ANY DISCREPANCIES TO THE ARCHITECT.
 - CONTRACTOR SHALL BE RESPONSIBLE FOR STABILITY OF THE STRUCTURE DURING CONSTRUCTION INCLUDING ALL SHORING AND BRACING REQUIRED TO RESIST REQUIRED VERTICAL AND LATERAL FORCES.
 - ALL ARCHITECTURAL FLOOR PLAN DIMENSIONS ARE FROM FACE OF CONCRETE, MASONRY AND FINISHED DRYWALL.
 - HORIZONTAL MASONRY DIMENSIONS FROM OUTSIDE TO OUTSIDE CORNERS ARE ACTUAL. WHEN DIMENSIONS ARE 2'-8" OR LESS, CONSTRUCT ONE JOINT LESS THAN DIMENSION SHOWN.
 - GYPSONUM BOARD PARTITIONS ARE TYPE G5a UNLESS INDICATED OTHERWISE.
 - CONTRACTOR SHALL PROVIDE 3/4" HIGH CONCRETE CURBS AT ALL ELECTRICAL PANELS AND WHERE 2 OR MORE CONDUITS ARE EXPOSED AT THE FLOOR LINE.
 - CONTRACTOR SHALL SIZE FORM, DOWEL AND POUR INTERIOR AND EXTERIOR BASES FOR MECHANICAL AND ELECTRICAL EQUIPMENT (3/4" AT INTERIOR LOCATIONS AND 5/8" AT EXTERIOR LOCATIONS UNLESS INDICATED OTHERWISE). REFER TO GENERAL PROVISIONS OF MECHANICAL SPECIFICATIONS FOR MINIMUM SIZES. UNLESS INDICATED OTHERWISE, REINFORCE WITH 4"x4" - W4.0x4.0 W/WF.
 - NO WALL FINISH OTHER THAN PAINT IS REQUIRED BEHIND CABINETS, CHALKBOARDS, TACKBOARDS, ETC UNLESS WALL BEHIND IS EXPOSED TO VIEW AND/OR WHERE NOTED OTHERWISE.
 - PROVIDE WALL BASE AT ALL CABINETS, SHELVING AND COLUMNS, AND AS SCHEDULED.
 - PROVIDE LINTELS (REF. STRUCTURAL AND MISC. LINTEL SCHEDULE) FOR ALL OPENINGS IN MASONRY WALLS FOR FIRE EXTINGUISHER CABINETS, LOUVERS, GRILLES, DOORS, ETC.
 - CONTINUE CONTROL JOINTS, INCLUDING SEALANTS, ABOVE CEILING ELEVATIONS FOR FULL HEIGHT OF WALL OR PARTITION.
 - PROVIDE 2x6 FIRE-RETARDANT TREATED BLOCKING IN GYPSONUM BOARD PARTITIONS BEHIND CASEWORK. BLOCK AT TOP OF BASE UNITS, TOP & BOTTOM OF WALL UNITS, TOP AND MID-HEIGHT OF TALL UNITS. PROVIDE 2x6 FIRE-RETARDANT TREATED BLOCKING IN GYPSONUM BOARD PARTITIONS BEHIND GRAB BARS, DOOR STOPS, WALL-MOUNTED SHELVING, WALL-MOUNTED TVs AND OTHER LOCATIONS AS SPECIFIED OR NOTED. CUT TO FIT SMOOTHLY BETWEEN STUDS & KERF AT STUD FLANGES TO FIT FIRMLY TO BACK OF DRYWALL.
 - REFER TO STRUCTURAL DRAWINGS AND SPECIFICATIONS FOR REINFORCING STEEL IN MASONRY WALLS AND POURED CONCRETE.
 - REFER TO CODE COMPLIANCE PLANS FOR FIRE RATINGS OF PARTITIONS AND SMOKE BARRIER LOCATIONS. GENERAL CONTRACTOR SHALL BE RESPONSIBLE FOR CONSTRUCTION OF PARTITIONS AND BARRIERS TO COMPLY WITH RATINGS INDICATED.
 - PROVIDE PAINT FINISH ON ALL EXPOSED BARE, PRIMED, OR GALVANIZED STEEL SURFACES ON BUILDING EXTERIOR AND SITE ELEMENTS. PAINT TYPE SHALL BE COMPATIBLE WITH SUBSTRATE IF NOT INDICATED OTHERWISE IN PROJECT SPECIFICATIONS.
 - PROVIDE SEALANT IN ALL JOINTS BETWEEN DISSIMILAR MATERIALS.
 - WALLS REQUIRED TO HAVE PROTECTED OPENINGS OR PENETRATIONS MUST BE PERMANENTLY IDENTIFIED WITH SIGNS OR STENCILING IN THE CONCEALED FLOOR, FLOOR-CEILING, OR ATTIC SPACES. SUCH IDENTIFICATION SHALL:
 - BE LOCATED WITH 20 FEET OF THE END OF EACH WALL AND INTERVALS NOT EXCEEDING 30 FEET MEASURED HORIZONTALLY ALONG THE WALL OR PARTITION ON ONE WALL/PARTITION SIDE ONLY.
 - INCLUDE LETTERING NOT LESS THAN 3 INCHES IN HEIGHT WITH MINIMUM 3/8" STROKE IN CONTRAST COLOR INCORPORATING THE WORDS "FIRE AND/OR SMOKE BARRIER-PROTECT ALL OPENINGS."

MATERIALS

	EARTH
	SAND
	GRANULAR FILL/ DRAINAGE MATERIAL
	ASPHALT PAVING
	CONCRETE (ELEVATION/SECTION)
	PRECAST CONC/PC, PLASTER/CUT STONE
	GROUT
	CONCRETE MASONRY UNIT AS NOTED
	INSULATION - FOUNDATION
	INSULATION - WALL
	STEEL
	WOOD FRAMING OR BLOCKING
	FINISH WOOD
	PLYWOOD
	TILE
	INSULATION - ROOF
	INSULATION - BATT
	GLASS (ELEVATION/SECTION)
	GYPSONUM BOARD (ELEVATION/SECTION)
	PARTICLE BOARD
	ACOUSTICAL CEILING PANEL OR TILE
	STONE (ELEVATION/SECTION)
	CAVITY DRAINAGE

PROJECT CONTACTS

OWNER
Washburn University
 1700 SW College Ave.
 Topeka, KS 66621

PROJECT CONTACT
 Tamara Hampton
 (785) 670-1848

ARCHITECT
HTK Architects
 900 S. Kansas Ave., Suite 200
 Topeka, KS 66612

PROJECT CONTACT
 Maria Nadra & Louis Weishaur
 (785) 266-5373

MECHANICAL, ELECTRICAL, PLUMBING ENGINEER
Latimer Sommers & Associates
 3639 SW Summerfield Dr., Suite A
 Topeka, KS 66614

PROJECT CONTACT
 Jim Latimer & Kyle Wolk
 (785) 233-3222

CONSTRUCTION MANAGER
MCP Build
 3501 SW Fairview Rd
 Topeka, KS 66614

PROJECT CONTACT
 TBD
 (785) 273-3880

SHEET INDEX

INFORMATION

G101	TITLE SHEET
G201	CODE FOOTPRINTS
ARCHITECTURAL	
D101	DEMOLITION PLANS
A101	ARCHITECTURAL FLOOR PLAN - LOWER LEVEL
A102	ARCHITECTURAL FLOOR PLAN - MAIN LEVEL
A103	ARCHITECTURAL FLOOR PLAN - UPPER LEVEL
A301	SECTIONS & DETAILS
A401	ROOF PLAN & DETAILS
A501	DOOR, FRAME, & WINDOW SCHEDULES & DETAILS
A601	REFLECTED CEILING PLAN - LOWER LEVEL
A602	REFLECTED CEILING PLAN - MAIN LEVEL
A603	REFLECTED CEILING PLAN - UPPER LEVEL
A801	SIGNAGE
FE101	FIXED EQUIPMENT ELEVATIONS & DETAILS
PLUMBING	
P100	LOWER LEVEL FLOOR PLAN - BELOW GRADE PLUMBING
P101	LOWER LEVEL FLOOR PLAN - PLUMBING
P102	MAIN LEVEL FLOOR PLAN - PLUMBING
P103	UPPER LEVEL FLOOR PLAN - PLUMBING
MECHANICAL	
ME001	MEP COVER SHEET
ME101	LOWER LEVEL FLOOR PLAN - DEMOLITION
ME102	MAIN LEVEL FLOOR PLAN - DEMOLITION
ME103	UPPER LEVEL FLOOR PLAN - DEMOLITION
ME104	LOWER LEVEL CEILING PLAN - DEMOLITION
ME105	MAIN LEVEL CEILING PLAN - DEMOLITION
ME106	UPPER LEVEL CEILING PLAN - DEMOLITION
ME201	BUILDING AUTOMATION SYSTEM DIAGRAMS
M101	LOWER LEVEL FLOOR PLAN - HVAC
M102	MAIN LEVEL FLOOR PLAN - HVAC
M103	UPPER LEVEL FLOOR PLAN - HVAC
M104	PENTHOUSE FLOOR PLAN - HVAC
MP101	MECHANICAL DETAILS
MP102	MECHANICAL SCHEDULES
ELECTRICAL	
E101	LOWER LEVEL FLOOR PLAN - POWER
E102	MAIN LEVEL FLOOR PLAN - POWER
E103	UPPER LEVEL FLOOR PLAN - POWER
E104	PENTHOUSE FLOOR PLAN - POWER
E201	LOWER LEVEL PLAN - LIGHTING
E202	MAIN LEVEL FLOOR PLAN - LIGHTING
E203	UPPER LEVEL FLOOR PLAN - LIGHTING
E301	ELECTRICAL DETAILS
E302	ELECTRICAL SCHEDULES
AUDIO/VISUAL	
AV101	LOWER LEVEL FLOOR PLAN - AUDIO/VISUAL
AV102	MAIN LEVEL FLOOR PLAN - AUDIO/VISUAL
AV103	UPPER LEVEL FLOOR PLAN - AUDIO/VISUAL
TELECOM	
T101	LOWER LEVEL FLOOR PLAN - TELECOM
T102	MAIN LEVEL FLOOR PLAN - TELECOM
T103	UPPER LEVEL FLOOR PLAN - TELECOM
T201	TELECOM DETAILS

MABEE LIBRARY RENOVATION

Washburn University
 1800 SW 19th Street, Topeka, KS 66621

DATE: July 16, 2024
 REVISED DATE:

SHEET CONTENTS:
 TITLE SHEET

HTK PROJECT NUMBER:
 2312.03

SHEET NUMBER:
G101

ORIGINAL CONTRACT DOCUMENTS

GENERAL INFORMATION:
 LOCATION: MABEE LIBRARY
 1800 SW 19th Street
 Topeka, KS 66621

AGENCY INFORMATION: WASHBURN UNIVERSITY
 1700 SW College Ave.
 Topeka, KS 66621

RESPONDING FIRE DEPARTMENT: Topeka Fire Department

REASON FOR SUBMITTAL: Renovation

AUTHORITIES HAVING JURISDICTION: City of Topeka

PROJECT DESCRIPTION:
 RENOVATION OF 3 FLOORS OF EXISTING STRUCTURE FOR OFFICES AND CLASSROOMS.

APPLICABLE CODES:
 2021- International Building Code
 2021- International Fire Code
 2016- International Residential Code
 2021- International Existing Building Code
 2015- Uniform Mechanical Code
 2018- Uniform Plumbing Code
 2015- International Fuel Gas Code
 2021- International Energy Conservation Code
 2010- ADAAG

NFPA 10-2018
 NFPA 13-2016
 NFPA 14-2016
 NFPA 25-2017
 NFPA 70-2017 (National Electrical Code)
 NFPA 72-2016 (National Fire Alarm Code)
 NFPA 101-2018
 NFPA 110-2016
 NFPA 241-2013
 Kansas Fire Prevention Code
 Kansas State Boiler Code KSA 44-913

State Law establishes a minimum Life Safety and has a uniform effect throughout the State. KSA 31-133 and KSA 2003 Supp. 31-134 require that all occupied structures conform to the basic life safety requirements: A) Existing occupied buildings cannot have hazardous conditions which slow speedy exits. B) Alteration of existing buildings cannot make existing conditions worse or block exits. C) New construction and changes in use are subject to greater life safety requirements.

OCCUPANCY & CONSTRUCTION TYPE:
 Occupancy Type: B (Business), A-2 (Cafe), A-3 (Conference-Accessory use to B), S-1 (Storage)
 Separation: Not required per 508.2 - Accessory Occupancies
 Construction Type: II-B

GENERAL BUILDING LIMITATIONS:
 Construction Type II-B Structural Fire Ratings Table 601
 Structural frame including columns, girders & trusses: 0 HR
 Bearing exterior walls: 0 HR
 Bearing interior walls: 0 HR
 Nonbearing exterior walls & partitions: 0 HR
 Nonbearing interior walls & partitions: 0 HR
 Floor construction including supporting beams & joists: 0 HR
 Roof construction including supporting beams & joists: 0 HR

ACTUAL BUILDING AREA:
 Gross Sq. Ft.: B
 Lower Level: 13,779 sq. ft.
 Main Level: 15,516 sq. ft.
 Upper Level: 19,484 sq. ft.

ALLOWABLE BUILDING AREA:
 B Occupancy
 Lower Level: 23,000 sq. ft.
 Main Level: 23,000 sq. ft.
 Upper Level: 23,000 sq. ft.

ALLOWABLE BUILDING HEIGHT:
 3 Stories
 39'

ACTIVE LIFE SAFETY SYSTEMS; REQUIRED / PROVIDED:
 Fire Alarm: YES / YES
 FACP: YES / YES
 Remote Annunciator Panel: NO / NO
 Smoke Detection: YES / YES
 MNS: NO / NO
 Exit Signs: YES / YES
 Egress Lighting: YES / YES
 Emergency Lights: NO / NO
 Backup Power: NO / NO
 Suppression- Standpipes: NO / NO
 Suppression- Automatic: YES / YES
 Fire Extinguishers: YES / YES

TRAVEL DISTANCE: Allowable = 150 ft.
COMMON PATH OF EGRESS: Allowable = 75 ft.

PLUMBING FIXTURE COUNT:

Occupancy Type	Occupant Load	Water Closet	Lavatory	Drinking Fountain	Service Sink		
LOWER LEVEL	138	3	3	2	2	2	1
MAIN LEVEL	155	3	3	2	2	2	1
UPPER LEVEL	195	3	3	2	2	2	1

TOTAL REQUIRED FIXTURES: 9 9 6 6 6 6 1
TOTAL PROVIDED FIXTURES: 12 12 9 9 8 8 2

PASSIVE LIFE SAFETY SYSTEMS:
 Corridor Ratings: Required/Provided: 0 Hour
 Stairwells: Required/Provided: 2 HR / 2 HR
 Shafts: Required/Provided: 2 Hour
 Occupancy Separations: A/B - 0 Hour per 508.2. Aggregate accessory occupancies do not occupy more than 10% of the floor area. B/S - 0 Hour

REGISTERED DESIGN PROFESSIONALS:
 HTK Architects
 800 S. Kansas Ave., Suite 200
 Topeka, KS 66612
 785-266-5373

CODE SYMBOL LEGEND		
SYMBOL	DESCRIPTION	PROTECTIVE ELEMENTS
EXT	EXT- EXTERIOR	
INT	EXT- INTERIOR (Assembly occ. over 50 and seats from floors.)	
FE	FIRE EXTINGUISHER	
FC	FIRE DEPT. CONNECTION	
STANDP	STANDPIPE	
HC	HOSE CABINET	
FRS	FIRE EXTINGUISHER SPACING (Show Radius)	Show Radius
NP	NON PROTECTED EXIT PATH	Show per exemption for fully sprinklered A, B, E, F, M, S, & U Occupancies
LP	LIMITED PROTECTION EXIT PATH	Automatic: Smoke Detection Throughout Exit Path.
PP	PROTECTED EXIT PATH	1 Hour Fire Barrier wall construction, 20-minute rated door assembly, Fire & Smoke Dampers.
SC	SPECIAL COVERAGE	Limited Sprinkler Coverage
1	1 HOUR EXIT PASSAGEWAY	1 Hour Fire Barrier wall construction. No openings other than required exit doors. 1-hour door assembly.
2	2 HOUR EXIT PASSAGEWAY	2 Hour Fire Barrier wall construction. No openings other than required exit doors. 1 1/2-hour door assembly.
1	1 HOUR EXIT ENCLOSURE (vertical shaft) - 3 stories or less	1 Hour Fire Barrier wall construction. No openings other than required exit doors. 1-hour door assembly.
2	2 HOUR EXIT ENCLOSURE (vertical shaft) - 4 stories or more	2 Hour Fire Barrier wall construction. No openings other than required exit doors. 1 1/2-hour door assembly.
1	1 HOUR FIRE BARRIER (Occupancy & Isolated Use Area)	1 Hour Fire Barrier wall construction, 3/4 hr. rated door assembly, Fire Dampers, 10' clear height.
2	2 HOUR FIRE BARRIER (Occupancy)	2 Hour Fire Barrier wall construction, 1 1/2 hour rated door assembly, Fire Dampers.
2	2 HOUR FIRE WALL (Building Separation)	2 Hour Fire Wall construction per IRC 705, 1 1/2 hour door assembly, Fire dampers other than fire doors are allowed to penetrate wall.
1	1 HOUR SHaft	1 Hour Fire Barrier wall construction, 1 hour door assembly, Fire Dampers.
2	2 HOUR SHaft	2 Hour Fire Barrier wall construction, 1 1/2 hour door assembly, Fire Dampers.
1	1 HOUR FIRE WALL (4 stories or more)	1 Hour Fire Barrier wall construction, 1 1/2 hour door assembly, Fire Dampers.
2	2 HOUR FIRE WALL (4 stories or more)	2 Hour Fire Wall construction per IRC 705, 1 1/2 hour door assembly, Fire dampers other than fire doors are allowed to penetrate wall.
SP	SPRINKLERED INCIDENTAL USE AREA	Wall construction to resist the passage of smoke from floor to floor, floor ceiling assembly, 1 1/2 hr. fire & smoke barrier door set or fire transfer grilles, Fire Dampers.
SP	FIRE PARTITION (swallowing occupancies) (1 1/2 hr. & 2 hr. occupancies)	1-hour fire barrier wall, 20-minute rated door assembly, Fire Dampers.
SP	SMOKE BARRIER (1 1/2 hr. & 2 hr. occupancies)	1-hour fire barrier wall, 20-minute rated door assembly, Fire Dampers.
SP	SMOKE PARTITION	Not required to have a fire-resistance rating. All other components are to resist the passage of smoke. Reference Chapter 7.
SP	ACCUMULATED EXIT WIDTH AT REQUIRED EXIT (lower width)	Occupancy/Required width
SP	PUBLIC FIRE HYDRANT (show distance from building)	Provided with
ROOM	ROOM DESIGNATION	Room Designation, Type, Room Area, Maximum Allowable Occupancy
40	40'	SHOW ACCUMULATED OCCUPANT LOADS FOR COMPLEX PATHS
TR	TRAVEL DISTANCE	
EL	EXIT SIGN & EMERGENCY LIGHT	
RENO	RENOVATION	Designates areas where the existing building is being modified or altered.
EXIST	EXISTING TO REMAIN	Designates areas where the existing building has no new work.

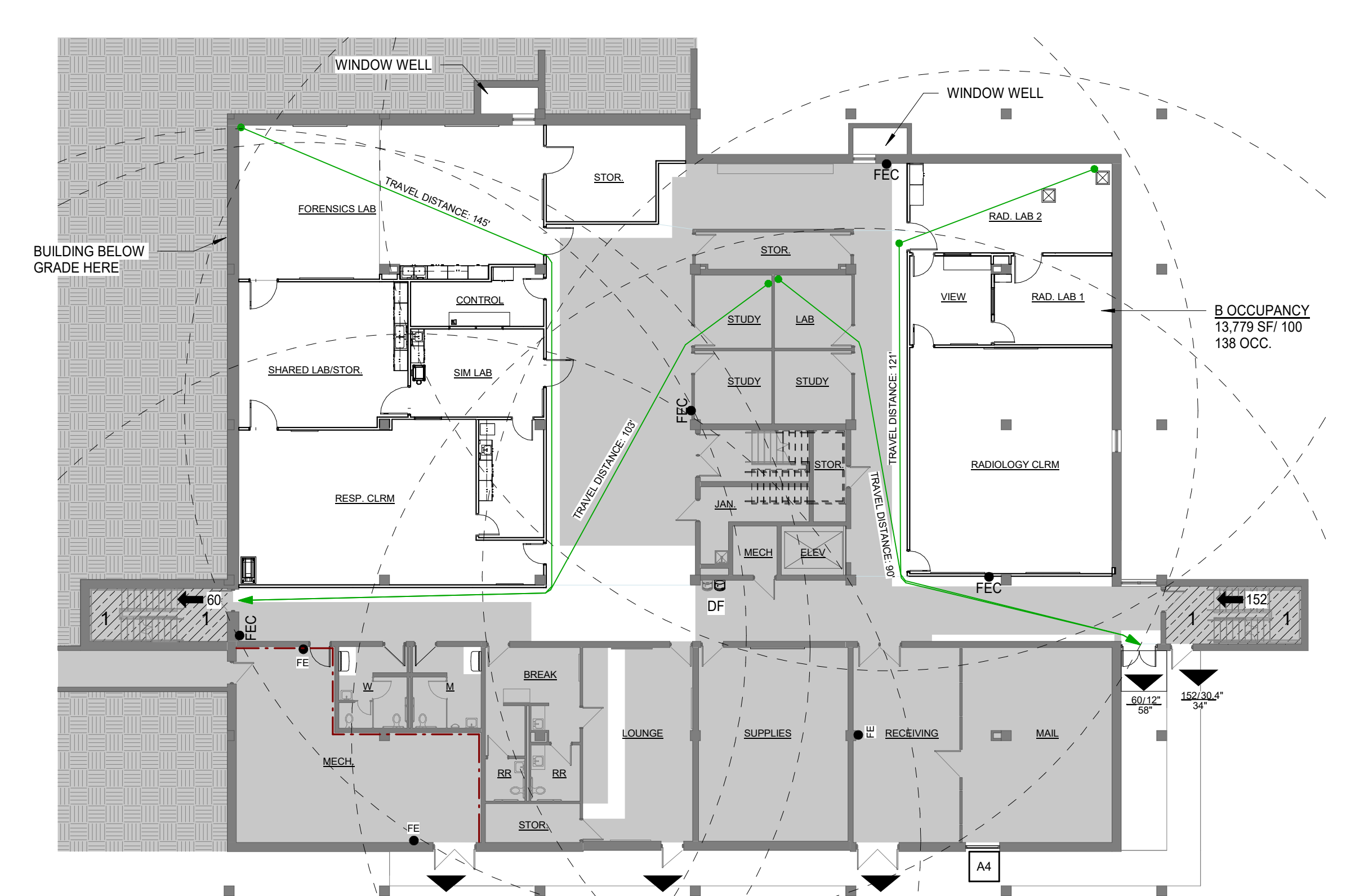

2 CODE FLOOR PLAN - LOWER LEVEL
 1/16" = 1'-0"

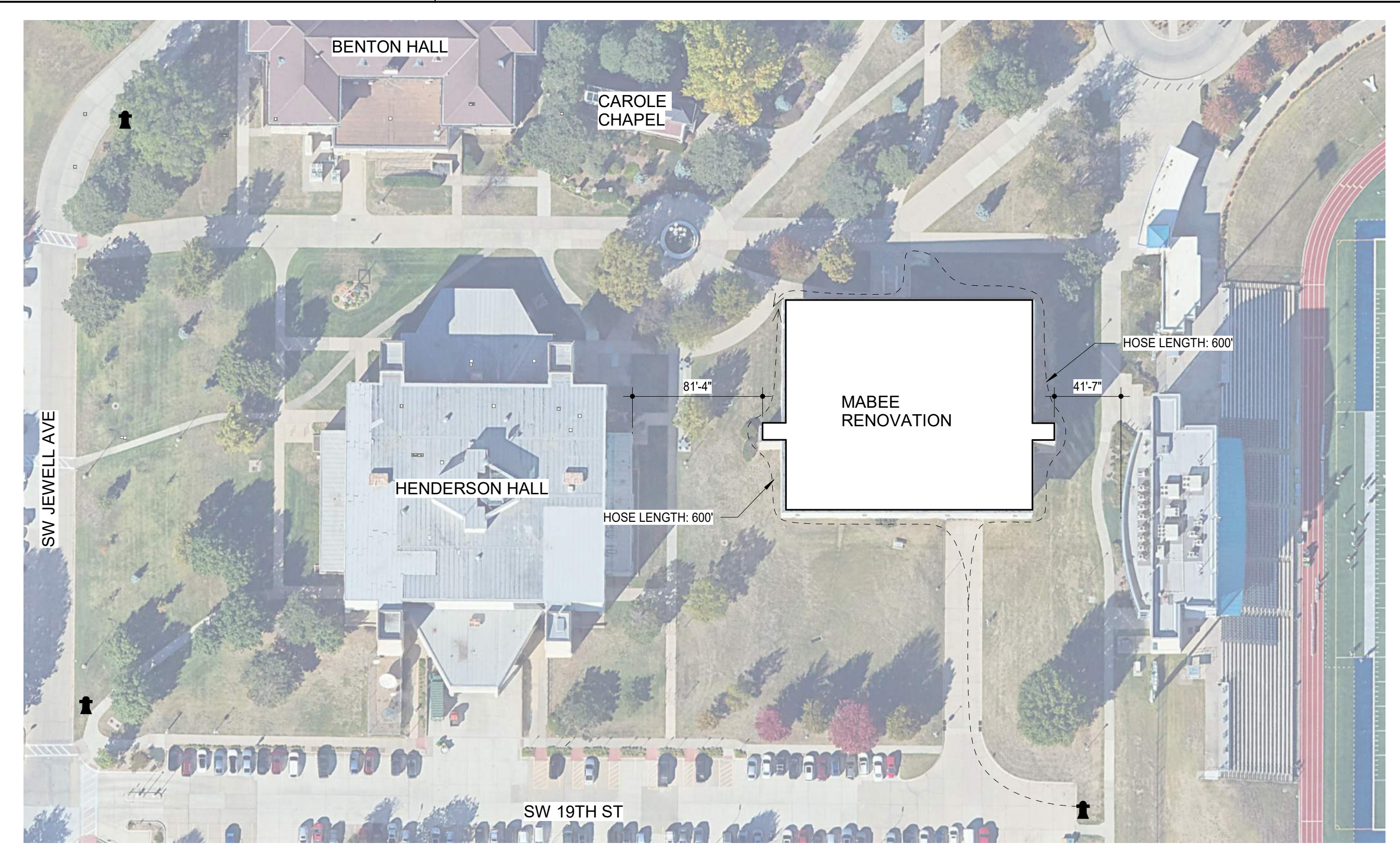

1 CODE SITE PLAN
 1" = 60'-0"



3 CODE FLOOR PLAN - MAIN LEVEL
 1/16" = 1'-0"

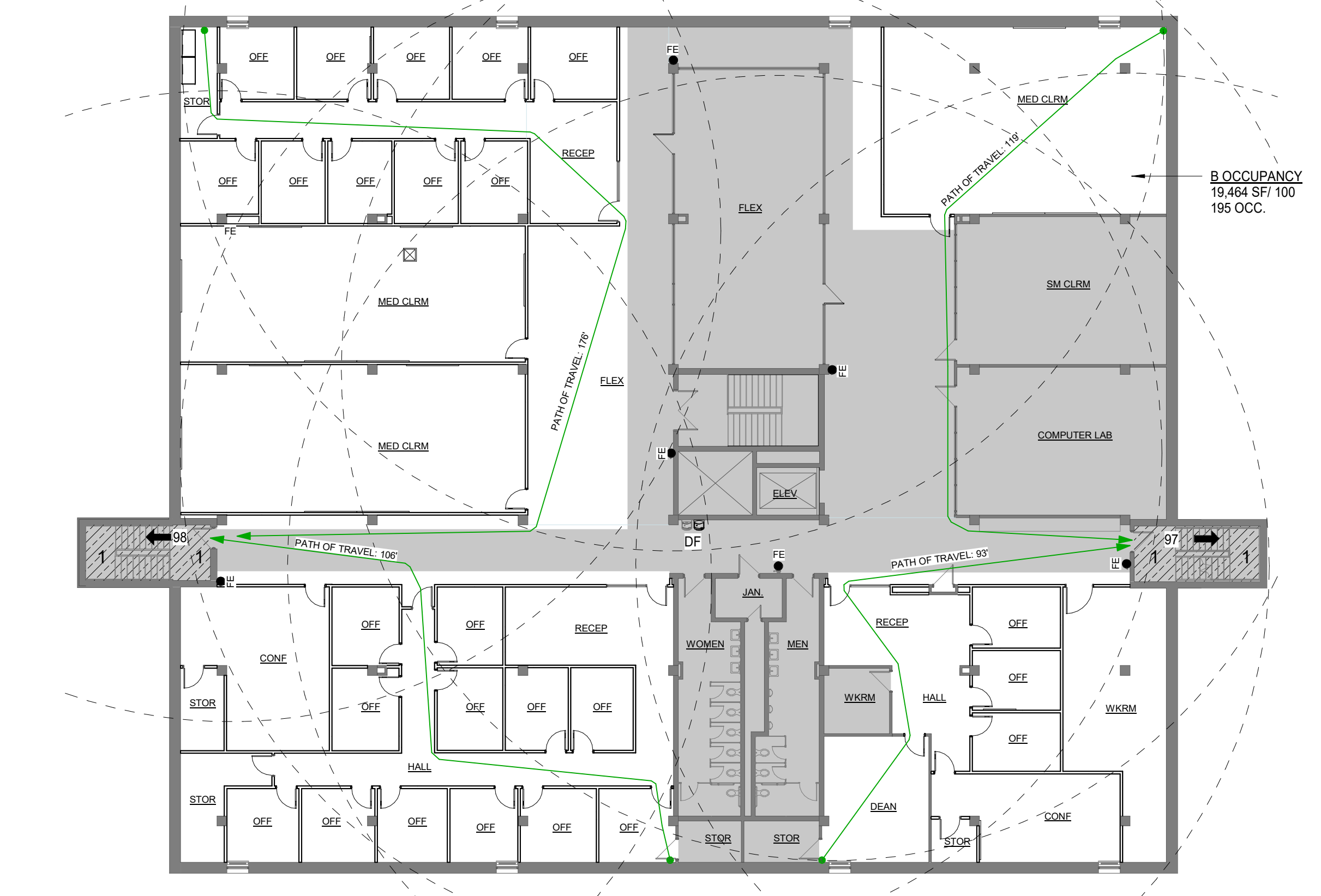

4 CODE FLOOR PLAN - UPPER LEVEL
 1/16" = 1'-0"

HTK ARCHITECTS

1800 SW 19th Street, Suite 200
 Topeka, Kansas 66612
 P 785-266-5373
 www.htkarchitects.com

Professional Seal: R. Keith
 License No. 16833
 State of Kansas
 Architect

DATE: July 16, 2024
 REVISED DATE:

MABEE LIBRARY RENOVATION

Washburn University
 1800 SW 19th Street, Topeka, KS 66621

SHEET CONTENTS:
 CODE FOOTPRINTS

HTK PROJECT NUMBER:
 2312.03

SHEET NUMBER:
G201

ORIGINAL CONTRACT DOCUMENTS



DATE: July 16, 2024
 REVISED DATE:

GENERAL DEMOLITION NOTES

- WALLS & STRUCTURE NOTED TO REMAIN SHALL BE BRACED & SUPPORTED AS NECESSARY DURING DEMO & UNTIL NEW CONSTRUCTION IS IN PLACE.
- PROTECT EXISTING CONSTRUCTION AND FINISHES TO REMAIN FROM DAMAGE DURING DEMOLITION.
- REPAIR SURFACES ADJACENT TO DEMOLITION AREAS AS REQUIRED TO MATCH ADJACENT FINISHES.
- COORDINATE DEMOLITION WORK WITH NEW WORK.
- REF. MECHANICAL, ELECTRICAL & PLUMBING FOR EXTENT OF RELATED DEMOLITION. REPAIR ALL WALLS/FLOOR/CEILING PENETRATIONS WHERE DEVICES/EQUIPMENT, ETC. WAS REMOVED. MATCH ADJ. FINISH & MATERIAL.
- REF. STRUCT FOR RELATED DEMOLITION.
- WHEN REPLACING SURFACE TO MATCH ADJACENT, MAKE NEW SURFACE FLUSH WITH ADJACENT UNLESS NOTED OTHERWISE.
- SOME NEW CONSTRUCTION WILL REQUIRE REMOVAL/CUTTING AND ADDITIONAL DEMO WORK NOT SHOWN ON DEMO SHEETS. REF. ENTIRE SET FOR DEMOLITION.
- FIELD VERIFY EXTENT OF DEMO ITEMS BEFORE BIDDING.
- DEMO WALLS & DOORS SHOWN DASHED IN AREAS OF NEW WORK. CONSULT ARCHITECT FOR ANY DISCREPANCIES OR QUESTIONS.
- WALLS, SLABS, CEILING, ETC. WITHIN RENOVATION AREAS NOT CALLED FOR DEMO SHALL BE PATCHED & REPAIRED TO MATCH ADJ. SURFACES & FINISHES. TYP. PRIOR TO FINISHING AS SCHED.
- WHERE NEW FINISHES ARE INDICATED ON PLANS, SPECIFICATIONS, OR SCHEDULES, ANY EXISTING FINISHES IN CONFLICT SHALL BE DEMOLISHED. CONTRACTOR SHALL FIELD VERIFY EXTENT OF EXISTING FINISHES PRIOR TO BIDDING.

DEMOLITION PLAN NOTES

GENERAL. COORDINATE WITH NEW CONSTRUCTION AND WORK SHOWN ON MECHANICAL, PLUMBING, AND ELECTRICAL DRAWINGS. DEMO ALL EXISTING ROOM SIGNAGE, PATCH & PAINT AT WALL

- DEMO DOOR & FRAME, WALL OR SOFFIT & ALL ELEMENTS IN WALL, FLOOR TILE OR CARPET FLOORING & WALL BASE, CEILING & LIGHTS, AND ALL CASEWORK OR CUBBIES. PREP FOR NEW CONSTRUCTION
- REMOVE PORTION OF EXISTING WALL AS REQ'D FOR NEW OPENING. PATCH & REPAIR SLAB & ADJ. WALLS TO SMOOTH SURFACE, TOOTH-IN MASONRY TO PROVIDE A SMOOTH TRANSITION WHERE APPLICABLE; PROVIDE SHORING AS REQ'D
- DEMO EXISTING FLOOR TILE OR CARPET FLOORING AND WALL BASE, W.O.
- NOT USED
- CUT SLAB AT NEW PLUMBING, TOILET, DRAIN, AND/OR OR ELEC. UNDER SLAB, REF. MEP
- NOT USED
- DEMO WALL INTO CHASE FOR MEP WORK
- DEMO EXISTING WALL OR SOFFIT AND ALL ELEMENTS IN WALL INCLUDING DOORS SHOWN DASHED
- DEMO EXISTING WINDOW, FRAME, BLOCKING & SILL
- NOT USED
- REMOVE EXISTING PLUMBING FIXTURE AND CAP OR EXTEND LINES AS REQ'D FOR NEW PLUMBING, REF. MEP
- REMOVE VINYL WALL COVERING & ADHESIVE AROUND COLUMN ON FACES LEFT EXPOSED IN NEW WORK
- DEMO EXISTING CASEWORK
- EQUIPMENT AND FURNITURE TO BE REMOVED & SALVAGED BY OWNER
- FLOORING TO REMAIN; PROTECT
- SALVAGE EXISTING FIRE EXTINGUISHER FOR REINSTALLATION INTO NEW FEC CABINETS
- DEMO FIRE EXTINGUISHER CABINET. PATCH WALL TO MATCH SURROUNDING FINISH
- SALVAGE METAL BUILDING SIGNAGE TO OWNER
- DEMO EXISTING HIGH DENSITY STORAGE SYSTEM AND FLOOR RAILS
- DEMO EXISTING SHELVING
- CASEWORK TO REMAIN; PROTECT

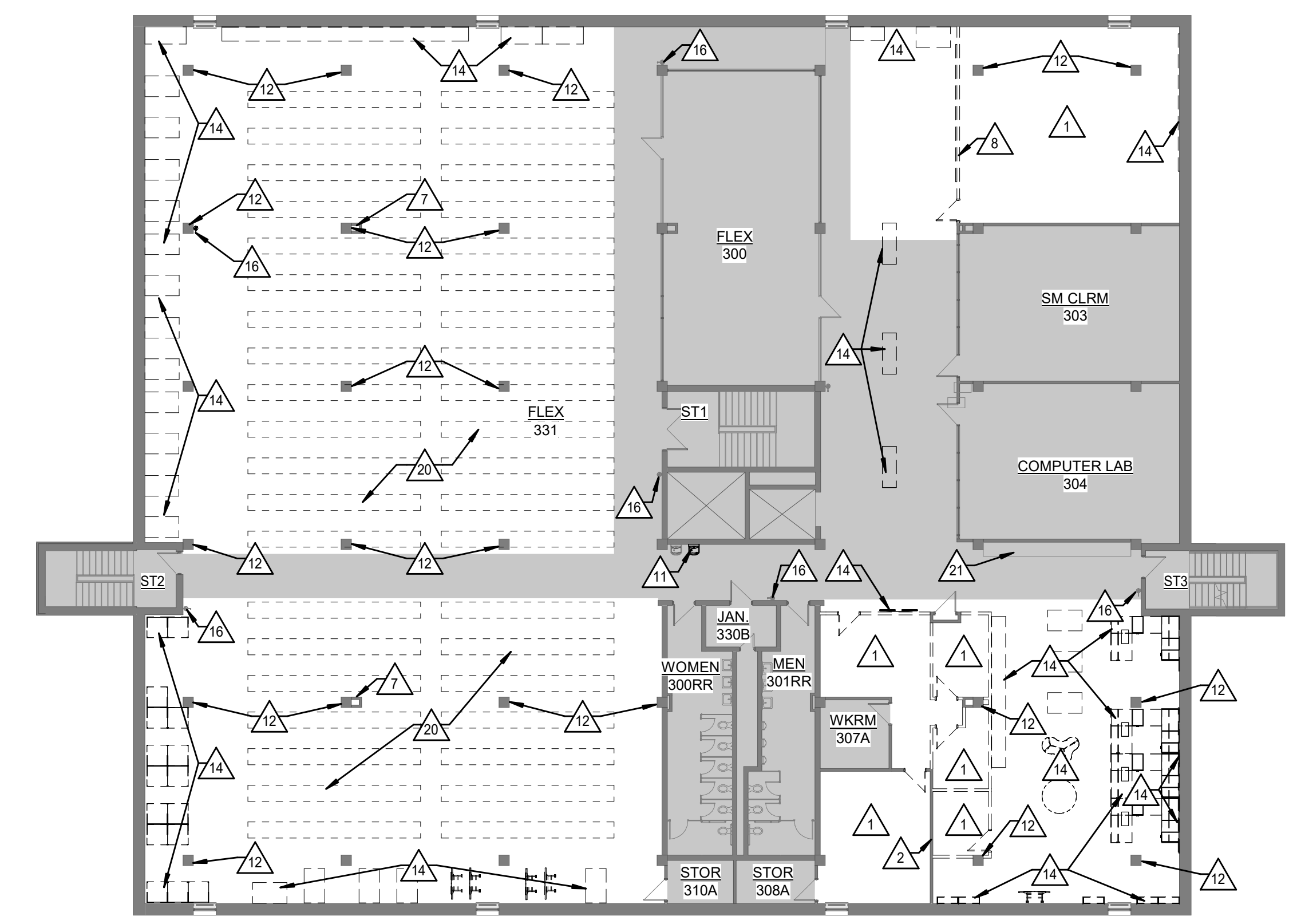

3 DEMOLITION PLAN - UPPER LEVEL
 1/16" = 1'-0" NORTH

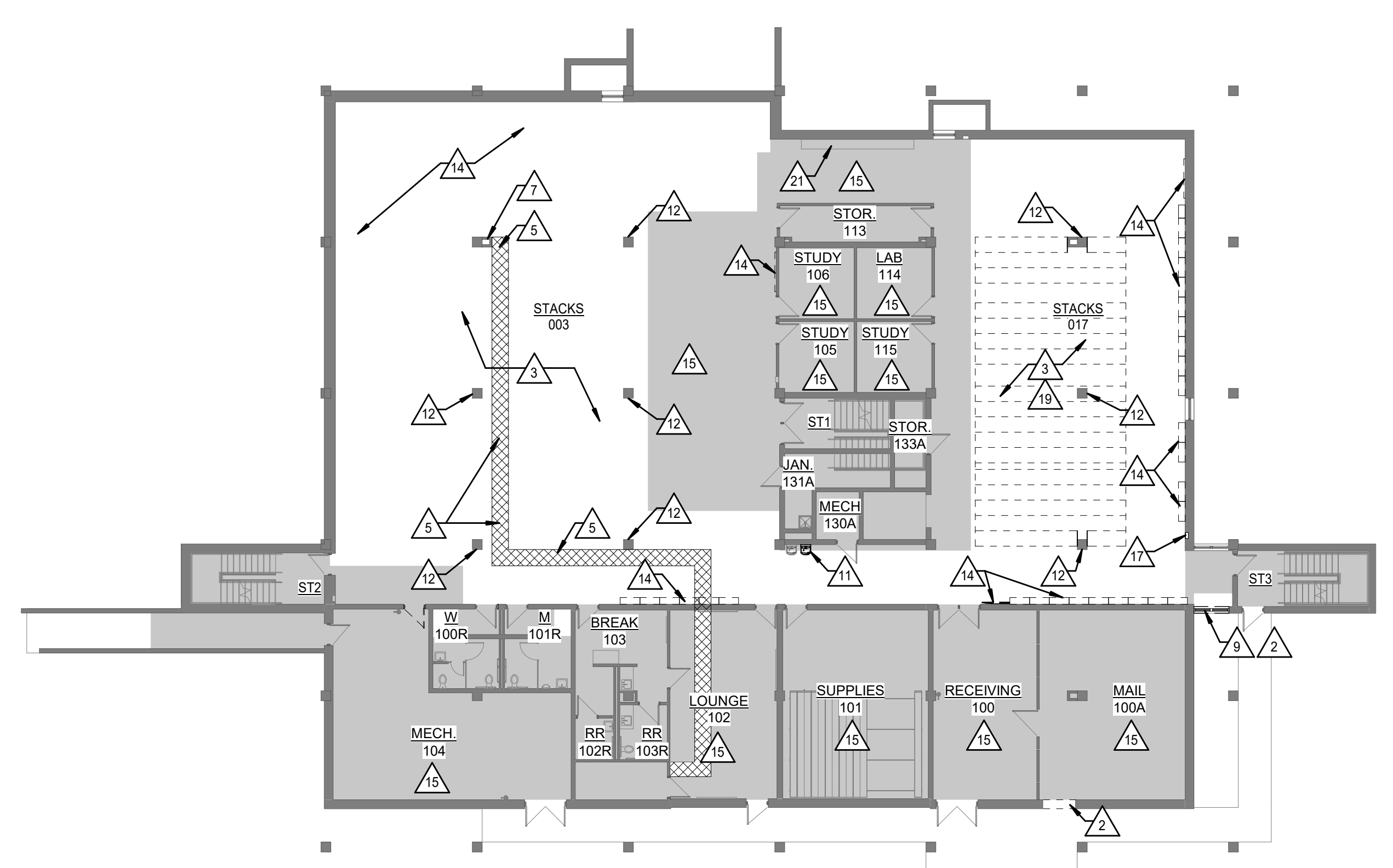

1 DEMOLITION PLAN - LOWER LEVEL
 1/16" = 1'-0" NORTH

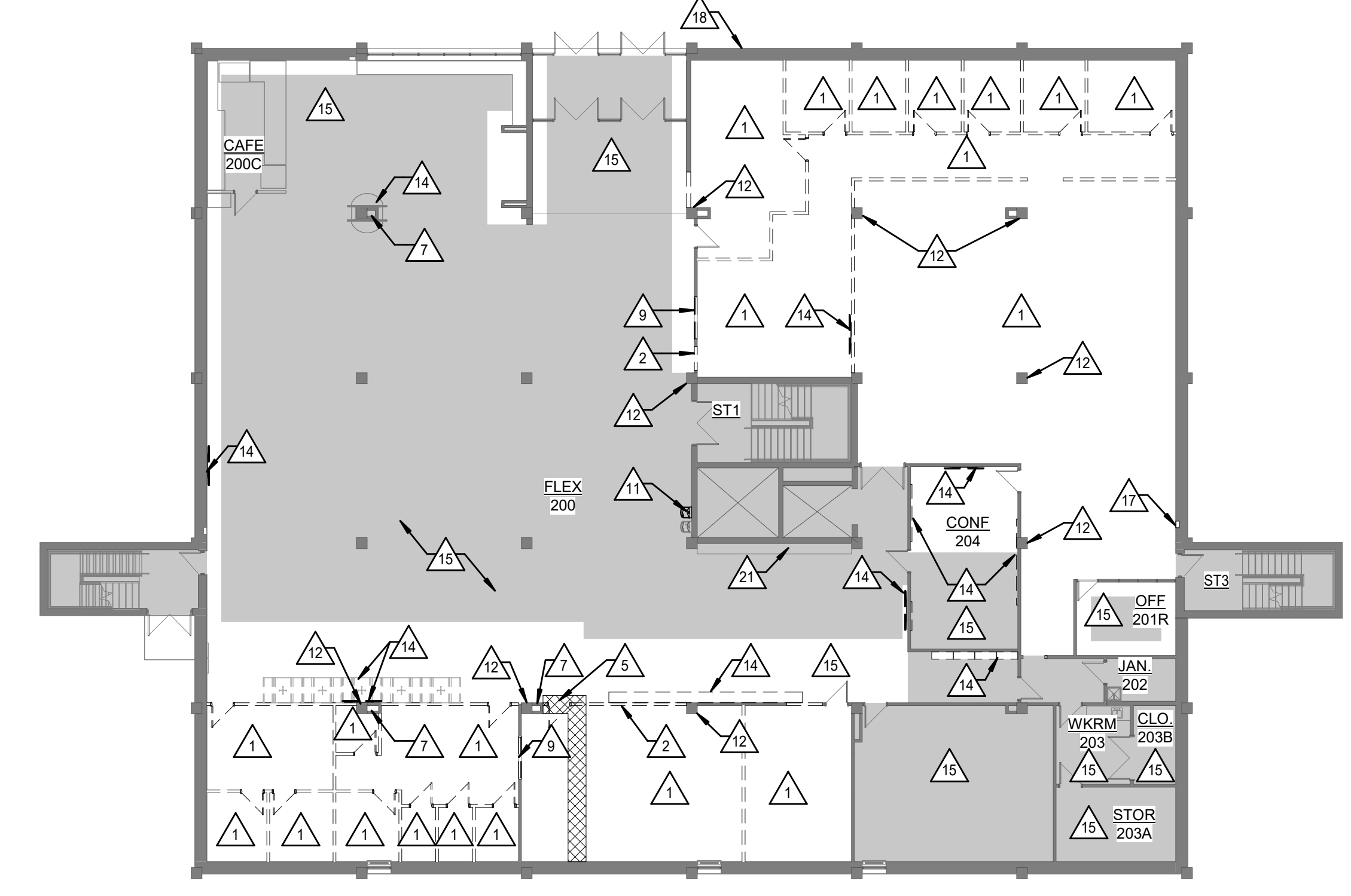

2 DEMOLITION PLAN - MAIN LEVEL
 1/16" = 1'-0" NORTH

NOTES:
 REFER TO SECTIONS AND DETAILS ON ALL OTHER SHEETS FOR APPLICABLE NOTES NOT SHOWN.

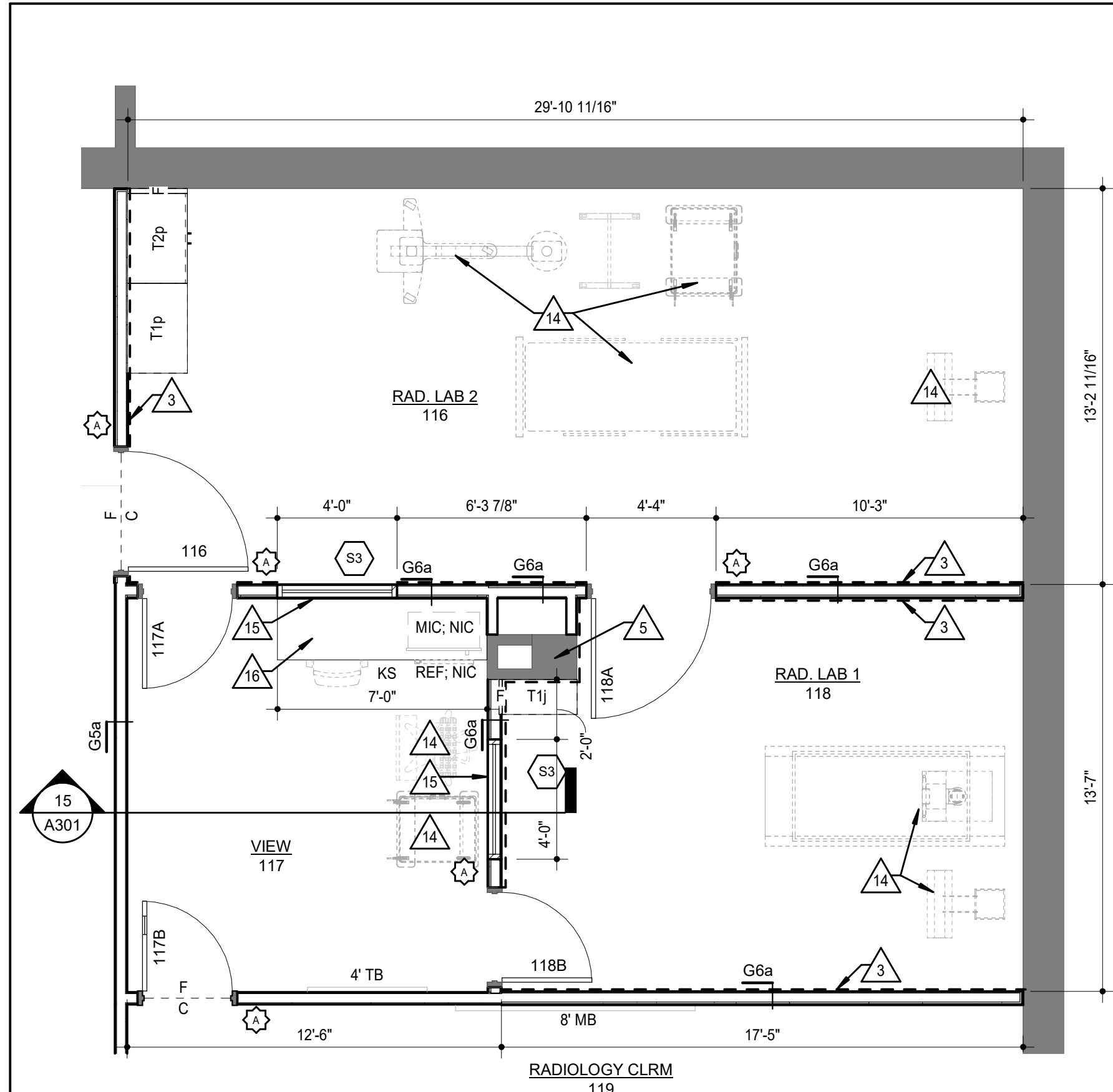

2 ENL. PLAN - RADIOLOGY LABS
1/4" = 1'-0"

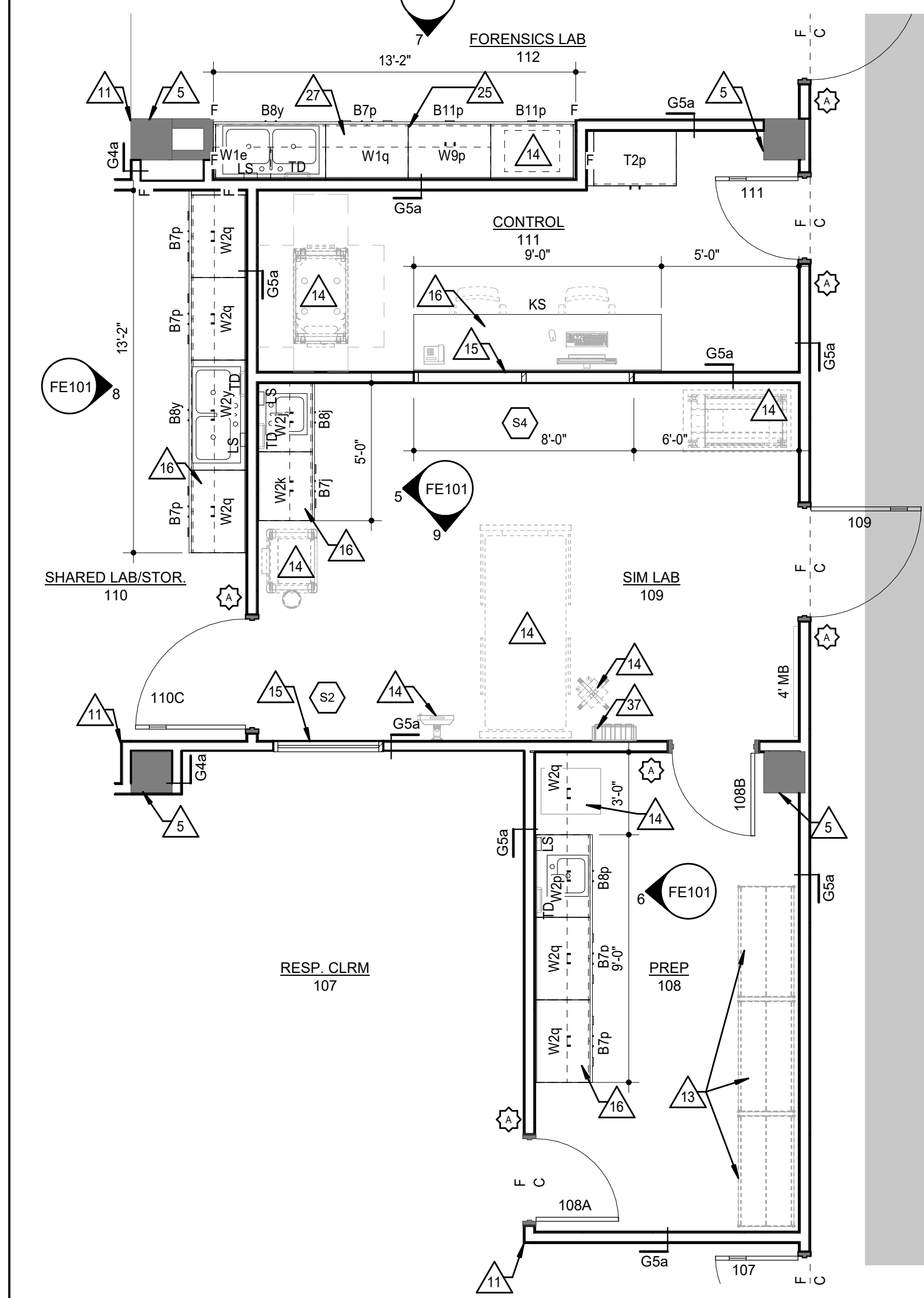

3 ENL. PLAN - CONTROL/LAB/PREP
1/4" = 1'-0"

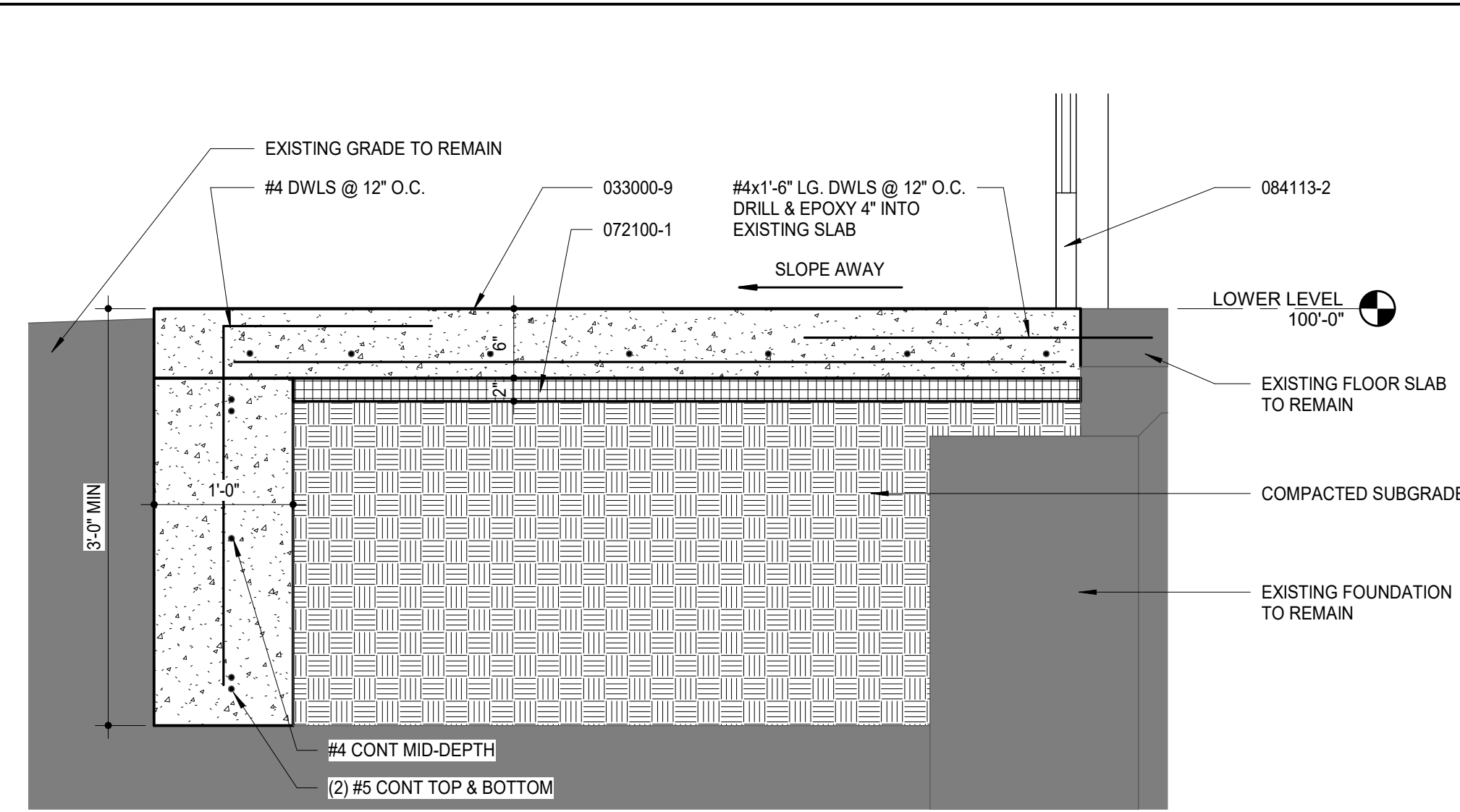

4 EXTERIOR STOOP
1" = 1'-0"

ROOM FINISH SCHEDULE - LOWER LEVEL

ROOM MARK	ROOM NAME	FLOOR	BASE	WALLS				NOTES
				NORTH	EAST	SOUTH	WEST	
100A	MAIL	CPT/EXIST	RB/EXIST	EXIST	EXIST	LPT	EXIST	1
102	LOUNGE	CPT/EXIST	EXIST	EXIST	EXIST	EXIST	EXIST	1
107	RESP. CLRM	CPT	RB	LPT	LPT	LPT	LPT	1
108	PREP	LVT	RB	EPT	EPT	EPT	EPT	1
109	SIM LAB	LVT	RB	EPT	EPT	EPT	EPT	1
110	SHARED LAB/STOR.	LVT	RB	EPT	EPT	EPT	EPT	1
111	CONTROL	CPT	RB	LPT	LPT	LPT	LPT	1
112	FORENSICS LAB	SV	SV	FRP/EPT	EPT	FRP/EPT	FRP	1
112A	STOR.	LVT	RB	LPT	LPT	LPT	LPT	1
116	RAD. LAB 2	LVT	RB	EPT	EPT	EPT	EPT	1
117	VIEW	LVT	RB	LPT	LPT	LPT	LPT	1
118	RAD. LAB 1	LVT	RB	EPT	EPT	EPT	EPT	1
119	RADIOLOGY CLRM	CPT	RB	LPT	LPT	LPT	LPT	1
130	HALL	CPT/EXIST	RB/EXIST	EPT	EXIST	EXIST	EXIST	1
131	HALL	CPT/EXIST	RB/EXIST	EPT	EXIST	EXIST	EPT	1
132	HALL	CPT/EXIST	RB	EXIST	EPT	EXIST	EPT	1
133	HALL	CPT/EXIST	RB/EXIST	EXIST	EPT	EXIST	EXIST	1

ROOM FINISH SCHEDULE LEGEND

FLOOR
 EXIST NO NEW FINISH, EXISTING TO REMAIN
 SC SEALED CONCRETE
 VCT VINYL COMPOSITION TILE
 PT PORCELAIN TILE
 CPT CARPET TILE
 RES RESINOUS FLOORING
 RTR RUBBER TREADS AND RISERS
 WOM WALK-OFF MAT

WALL BASE
 EXIST NO NEW FINISH, EXISTING TO REMAIN
 RB RESILIENT BASE (4" HIGH)
 RES EPOXY COVE BASE

WALLS
 EXIST NO NEW FINISH, EXISTING TO REMAIN
 LPT LATEX PAINT
 EPT EPOXY PAINT
 PWT PORCELAIN WALL TILE
 CT CERAMIC TILE

NOTES
 1 PROVIDE NEW FINISHES AT NEW WALLS, PATCH EXISTING WALLS AND FINISHES AS REQUIRED
 2 WALL BASE AT NEW WALL
 3 PAINT & WALL BASE IF ALTERNATE FOR NEW WALL IS ACCEPTED

PAINT LEGEND

PAINT WALL
 # PAINT COLOR

PAINT OVERHEAD ELEMENT
 # PAINT COLOR

PAINT ACCENT
 1 PAINT 1 (FIELD WHITE)
 MFR: BENJAMIN MOORE
 COLOR: SPRING THAW
 2 PAINT 2 (ACCENT)
 MFR: BENJAMIN MOORE
 COLOR: IN THE NAVY
 3 PAINT 3 (FRAME & TRIM COLOR)
 MFR: BENJAMIN MOORE
 COLOR: MATCH EXISTING

GENERAL PAINT NOTES
 1 UNLESS NOTED OTHERWISE, USE PAINT 1 (FIELD COLOR)
 2 ALL DOOR FRAMES, RAILINGS, MECHANICAL GRILLS THAT WERE PREVIOUSLY PAINTED, & TRIM ARE TO BE PAINTED PAINT 3, U.N.O.

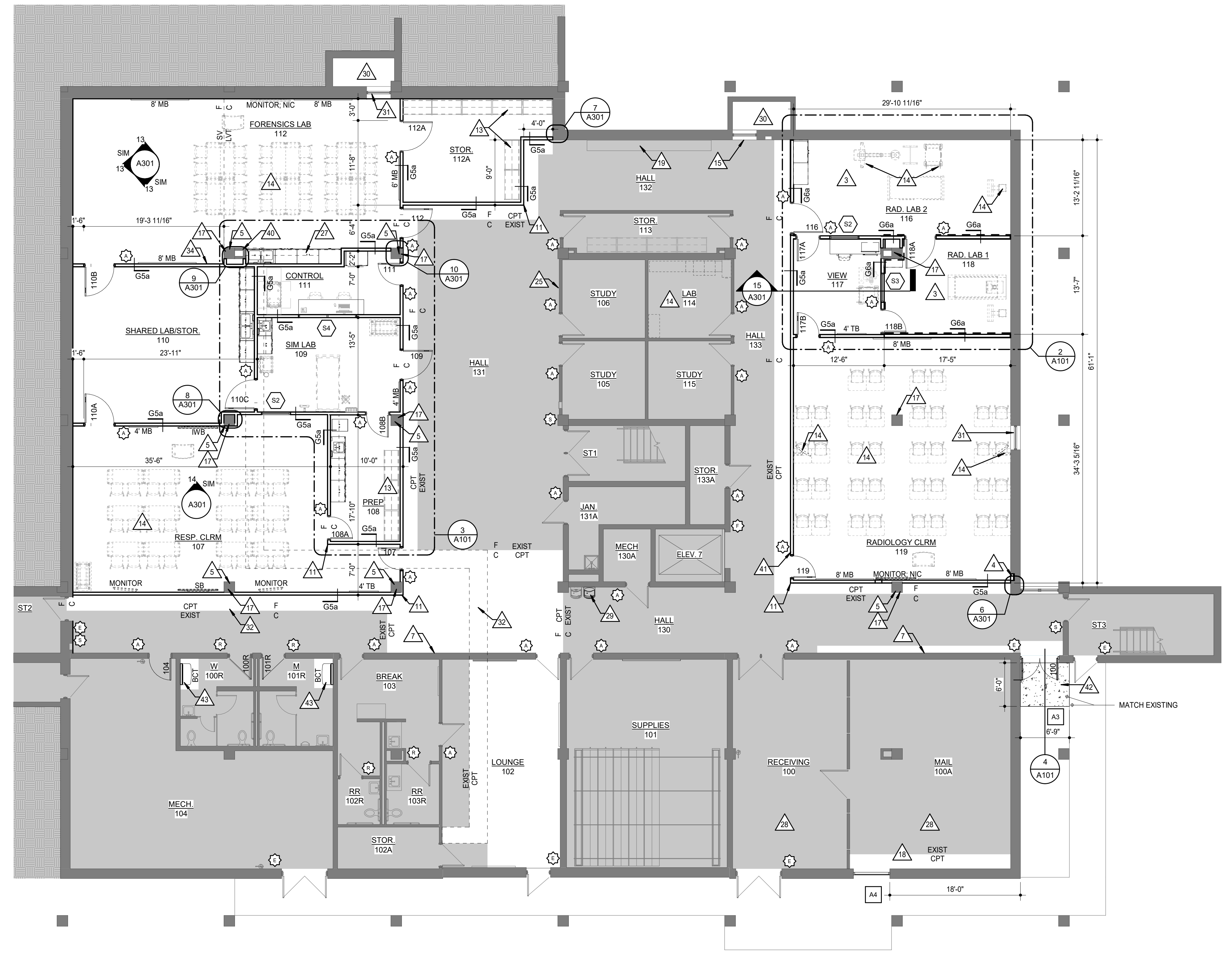

1 ARCHITECTURAL FLOOR PLAN - LOWER LEVEL
1/8" = 1'-0"

ARCHITECTURAL PLAN NOTES

GENERAL: COORDINATE WITH WORK SHOWN ON MECHANICAL, PLUMBING, AND ELECTRICAL DRAWINGS

- △ PROVIDE FIRE EXTINGUISHER CABINET, REF. 5/A301
- △ EXISTING FLOOR CHANGE TO REMAIN
- △ LEAD LINED GYP. BD. FOR 7" A.F.F.; LEAD GYP THICKNESS, LEAD WINDOW AND DOOR TO BE INCLUDED IN GC ALLOWANCE
- △ INFILL EXISTING WALL OPENING, PATCH TO MATCH ADJ. SURFACES FOR LIKE NEW APPEARANCE; PAINT WALL CORNER TO CORNER
- △ EXISTING COLUMN TO REMAIN; PROTECT
- △ EXISTING DOOR TO REMAIN; PROTECT
- △ PATCH WALL & PAINT CORNER TO CORNER
- △ PATCH CMU @ PLUMBING WORK; TOOTH IN MASONRY
- △ EXISTING ELECTRICAL PANEL TO REMAIN; PROTECT
- △ PATCH SLAB @ NEW PLUMBING IN EXISTING SLAB; REF. MEP & A100 FOR LOCATIONS
- △ CORNER GUARD; MOUNT ABOVE WALL BASE
- △ NOT USED
- △ SHELVING BY OWNER
- △ FURNITURE OR EQUIPMENT BY OWNER
- △ MANUAL ROLLER SHADE
- △ SOLID SURFACE COUNTERTOP
- △ SKIM COAT EXISTING COLUMNS W/ DRYWALL COMPOUND
- △ PATCH FLOORING WITH EXISTING CARPET TILE
- △ EXISTING CASEWORK TO REMAIN; PROTECT
- △ PATCH FLOORING & WALL @ WALL DEMO
- △ NOT USED
- △ PATCH WALL @ EXISTING WALL REMOVAL
- △ IT EQUIPMENT TO REMAIN
- △ PROVIDE FIRE EXTINGUISHER CABINET, REF. A302
- △ METAL LAB CASEWORK
- △ EXISTING PIPING TO REMAIN; PROTECT
- △ STAINLESS STEEL COUNTERTOP
- △ ROOM OCCUPIED THROUGHOUT CONSTRUCTION FOR CAMPUS MAIL SERVICE. MAINTAIN OPERATION & ACCESS FROM OUTSIDE
- △ PROVIDE DRINKING FOUNTAIN; REF. MEP
- △ WINDOW WELL TO REMAIN
- △ MANUAL BLACKOUT SHADE
- △ AREA OF FLOOR FILL, REF. DETAIL ON A301
- △ DIMENSIONAL LETTER SIGNAGE
- △ PROVIDE BLOCKING FOR OWNER PROVIDED EQUIPMENT
- △ NEW G5a WALL BY ALT.
- △ ROOM SCHEDULER; REF. MEP
- △ HEAD WALL, REMOVED FROM EXISTING LOCATION, REINSTALL IN NEW LOCATION
- △ GLAZED WALL TILE TO 5'-6" AFF. U.N.O. REF. RESTROOM ELEVATIONS A101
- △ CUSTOM WALL GRAPHIC BY ALT.; REF. ELEVATIONS A801; PATCH WALL AND PROVIDE LEVEL 5 GYP. BD. FINISH, PATCH WALL AND PROVIDE LEVEL 5 GYP. BD. FINISH
- △ PATCH CHASE AT NEW MEP WORK
- △ CARD READER; REF. MEP
- △ CONCRETE STOOP, REF. DTL.
- △ PROVIDE DIAPER CHANGING STATION 102800-14

NOTES:
 REFER TO SECTIONS AND DETAILS ON ALL OTHER SHEETS FOR APPLICABLE NOTES NOT SHOWN.

HTK ARCHITECTS

325 W. 11TH ST., STE. 150
 TOPEKA, KANSAS 66612
 P 785.266.5373
 www.htkarchitects.com

MABEE LIBRARY RENOVATION

Washburn University
 1800 SW 19th Street, Topeka, KS 66621

SHEET CONTENTS:
 ● ARCHITECTURAL FLOOR PLAN - LOWER LEVEL

HTK PROJECT NUMBER:
 ● 2312.03

SHEET NUMBER:
A101

ORIGINAL CONTRACT DOCUMENTS

DATE:
 ● July 16, 2024

REVISED DATE:
 ●

TYP. TLT. & ACCESS. MTG. HGTS.

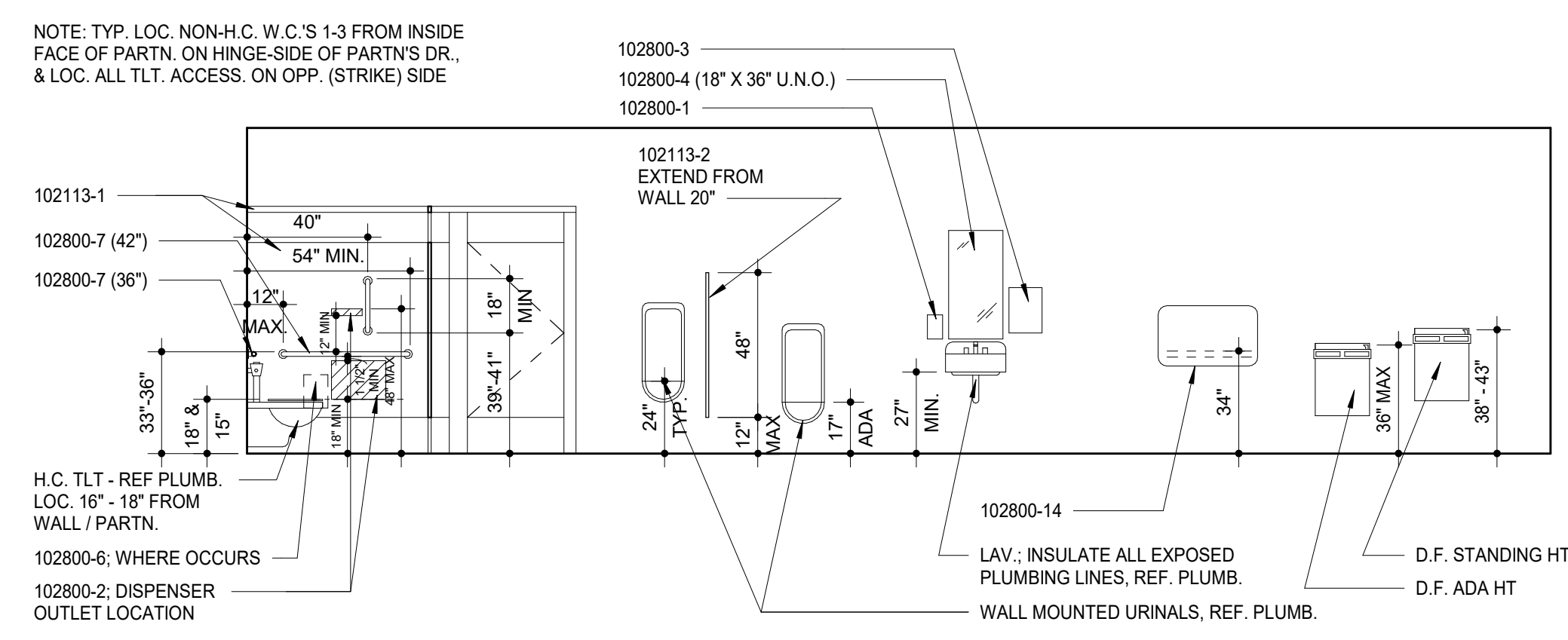

5 MAIN FLOOR DF WALL ELEV.

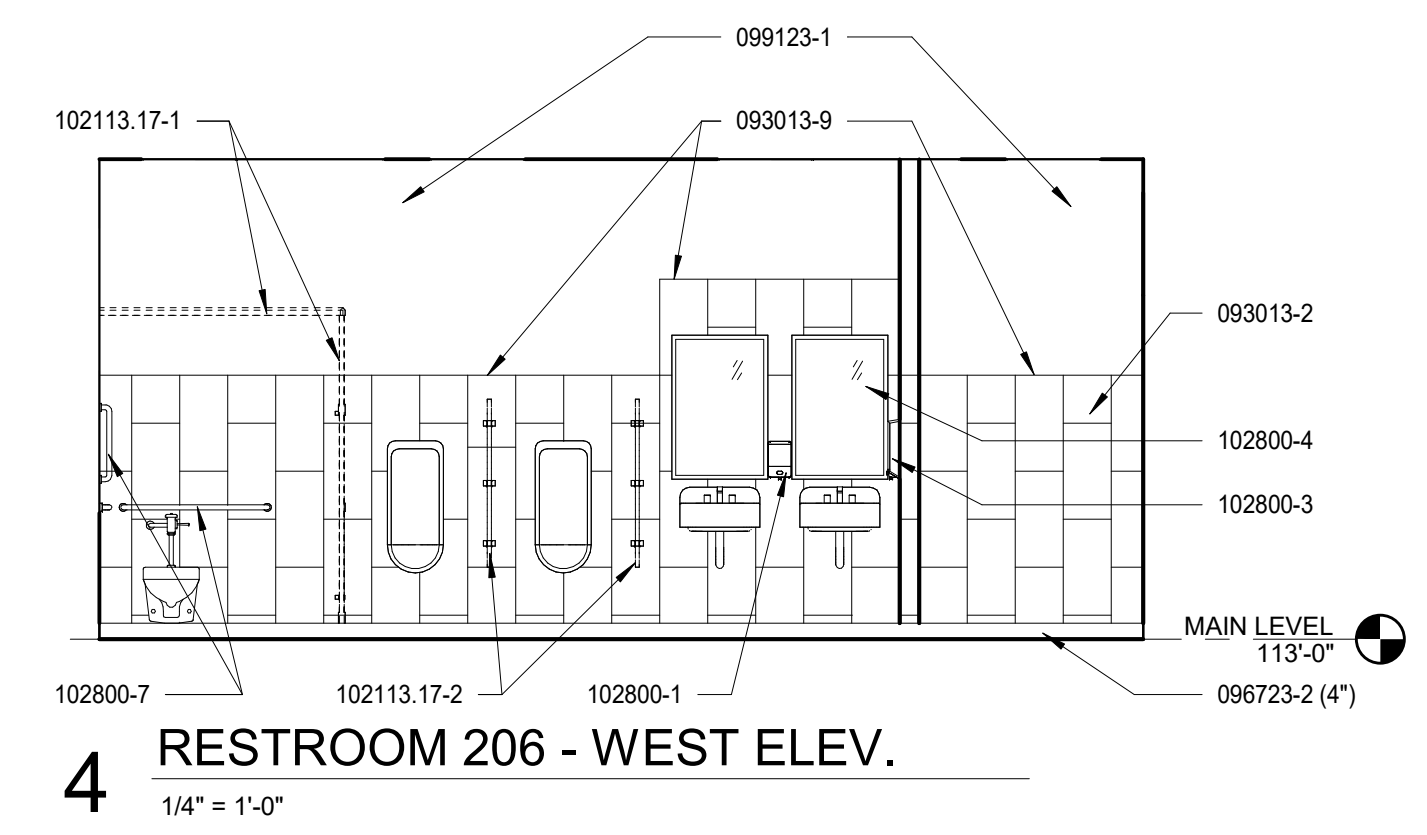
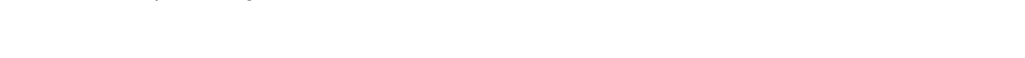

PAINT LEGEND

PAINT WALL "P" PAINT COLOR
PAINT OVERHEAD ELEMENT "P" PAINT COLOR

PAINT ACCENT:
1 PAINT 1 (FIELD WHITE)
MFR: BENJAMIN MOORE
COLOR: SPRING THAW
2 PAINT 2 (ACCENT)
MFR: BENJAMIN MOORE
COLOR: IN THE NAVY
3 PAINT 3 (FRAME & TRIM COLOR)
MFR: BENJAMIN MOORE
COLOR: MATCH EXISTING

GENERAL PAINT NOTES:
1. UNLESS NOTED OTHERWISE, USE PAINT 1 (FIELD COLOR)
2. ALL DOOR FRAMES, RAILINGS, MECHANICAL GRILLS THAT WERE PREVIOUSLY PAINTED, & TRIM ARE TO BE PAINTED PAINT 3, U.N.O.

ROOM FINISH SCHEDULE LEGEND

FLOOR
EXIST NO NEW FINISH; EXISTING TO REMAIN
SC SEALED CONCRETE
VCT VINYL COMPOSITION TILE
PT PORCELAIN TILE
CPT CARPET TILE
RES RESINOUS FLOORING
RTR RUBBER TREADS AND RISERS
WOM WALK-OFF MAT

WALL BASE
EXIST NO NEW FINISH; EXISTING TO REMAIN
RB RESILIENT BASE (4" HIGH)
RES EPOXY COVE BASE

WALLS
EXIST NO NEW FINISH; EXISTING TO REMAIN
LPT LATEX PAINT
EPT EPOXY PAINT
PWT PORCELAIN WALL TILE
CT CERAMIC TILE

NOTES:
1. PROVIDE NEW FINISHES AT NEW WALLS. PATCH EXISTING WALLS AND FINISHES AS REQUIRED
2. WALL BASE AT NEW WALL
3. PAINT & WALL BASE IF ALTERNATE FOR NEW WALL IS ACCEPTED

ROOM FINISH SCHEDULE - MAIN LEVEL

ROOM MARK	ROOM NAME	FLOOR	BASE	WALLS				NOTES
				NORTH	EAST	SOUTH	WEST	
200	FLEX	EXIST	RB/EXIST	EPT	EPT	EPT	EPT	1
200C	CAFE	EXIST	EXIST	EPT	EPT	EPT	EPT	
200RR	WOMEN	PT	PTB	PWT/EPT	PWT/EPT	EPT	EPT	
200V	VESTIBULE	EXIST	EXIST	EPT	EPT	EXIST	LPT	
201	RECEP	CPT	RB	LPT	LPT	LPT	LPT	
201A	OFF	CPT	RB	LPT	LPT	LPT	LPT	
201B	STOR	CPT	RB	LPT	LPT	LPT	LPT	
201C	OFF	CPT	RB	LPT	LPT	LPT	LPT	
201D	OFF	CPT	RB	LPT	LPT	LPT	LPT	
201E	OFF	CPT	RB	LPT	LPT	LPT	LPT	
201F	OFF	CPT	RB	LPT	LPT	LPT	LPT	
201G	OFF	CPT	RB	LPT	LPT	LPT	LPT	
201H	OFF	CPT	RB	LPT	LPT	LPT	LPT	
201H1	HALL	CPT	RB	LPT	LPT	LPT	LPT	
201H2	HALL	CPT	RB	LPT	LPT	LPT	LPT	
201H3	HALL	CPT	RB	LPT	LPT	LPT	LPT	
201H4	HALL	CPT	RB	LPT	LPT	LPT	LPT	
201H5	HALL	CPT	RB	LPT	LPT	LPT	LPT	
201J	OFF	CPT	RB	LPT	LPT	LPT	LPT	
201K	OFF	CPT	RB	LPT	LPT	LPT	LPT	
201L	OFF	CPT	RB	LPT	LPT	LPT	LPT	
201M	OFF	CPT	RB	LPT	LPT	LPT	LPT	
201N	OFF	CPT	RB	LPT	LPT	LPT	LPT	
201O	OFF	CPT	RB	LPT	LPT	LPT	LPT	
201P	OFF	CPT	RB	LPT	LPT	LPT	LPT	
201Q	OFF	CPT	RB	LPT	LPT	LPT	LPT	
201R	OFF	EXIST	EXIST	LPT	LPT	LPT	LPT	
201RR	MEN	PT	PTB	PWT/EPT	EPT	EPT	PWT/EPT	
201S	OFF	CPT	RB	LPT	LPT	LPT	LPT	
201T	OFF	CPT	RB	LPT	LPT	LPT	LPT	
201U	OFF	CPT	RB	LPT	LPT	LPT	LPT	
201V	OFF	CPT	RB	LPT	LPT	LPT	LPT	
201W	OFF	CPT	RB	LPT	LPT	LPT	LPT	
201X	OFF	CPT	RB	LPT	LPT	LPT	LPT	
201Y	OFFICE	CPT	RB	LPT	LPT	LPT	LPT	
204	CONF	EXIST	EXIST	LPT	EXIST	EXIST	EXIST	2
205	CLRM	EXIST	EXIST	EXIST	EXIST	EXIST	EXIST	3
206	WAITING	CPT	RB	LPT	LPT	LPT	LPT	
207	OFF	RB	LPT	LPT	LPT	LPT	LPT	
208	OFF	RB	LPT	LPT	LPT	LPT	LPT	
209	WELLNESS	LVT	RB	LPT	LPT	LPT	LPT	
210	RECEP	CPT	RB	LPT	LPT	LPT	LPT	
210A	OFF	CPT	RB	LPT	LPT	LPT	LPT	
210B	OFF	CPT	RB	LPT	LPT	LPT	LPT	
210C	OFF	CPT	RB	LPT	LPT	LPT	LPT	
210D	OFF	CPT	RB	LPT	LPT	LPT	LPT	
210E	OFF	CPT	RB	LPT	LPT	LPT	LPT	
210F	STOR	CPT	RB	LPT	LPT	LPT	LPT	
210G	OFF	RB	LPT	LPT	LPT	LPT	LPT	
210H	OFF	CPT	RB	LPT	LPT	LPT	LPT	
210H1	HALL	CPT	RB	LPT	LPT	LPT	LPT	

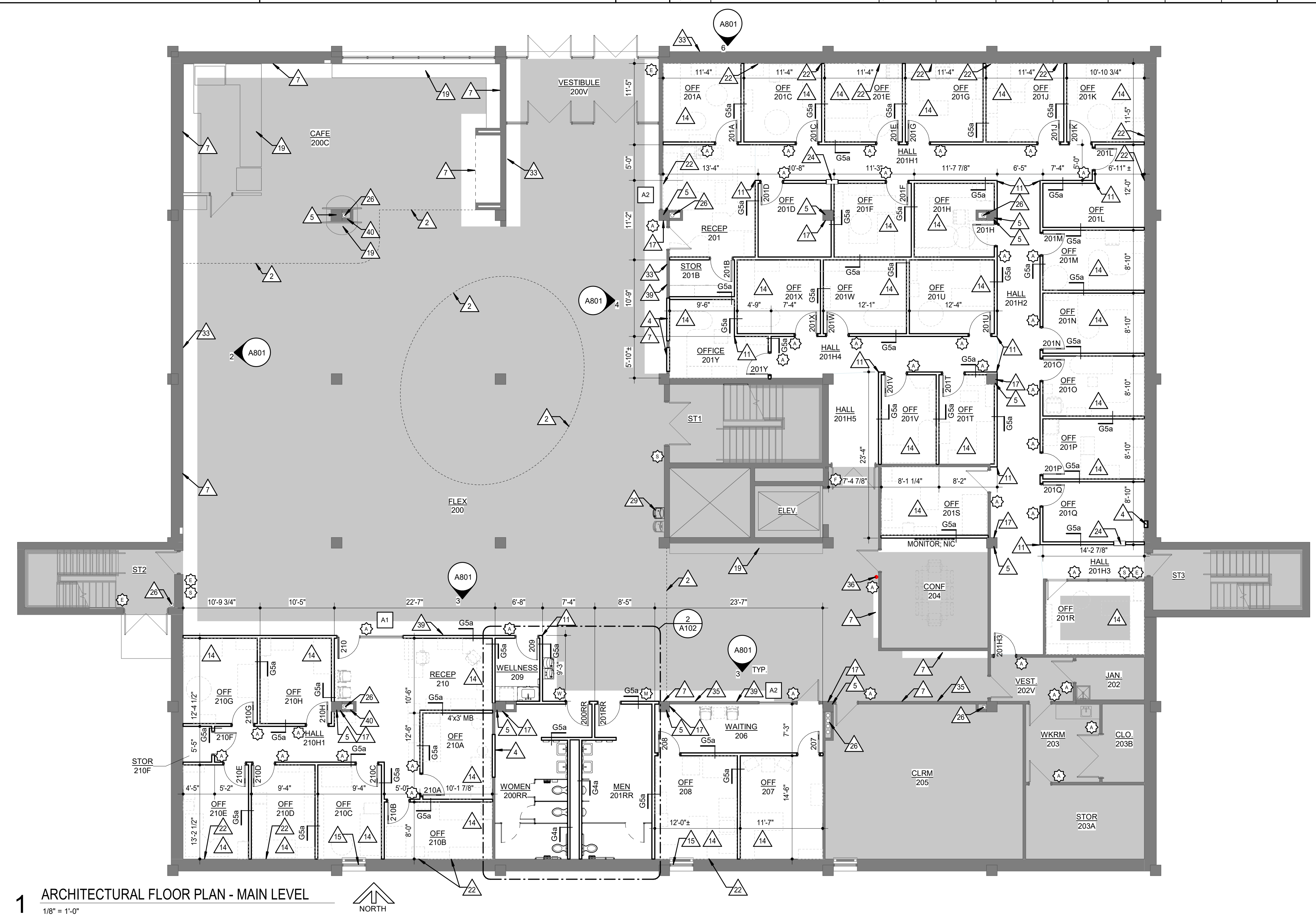
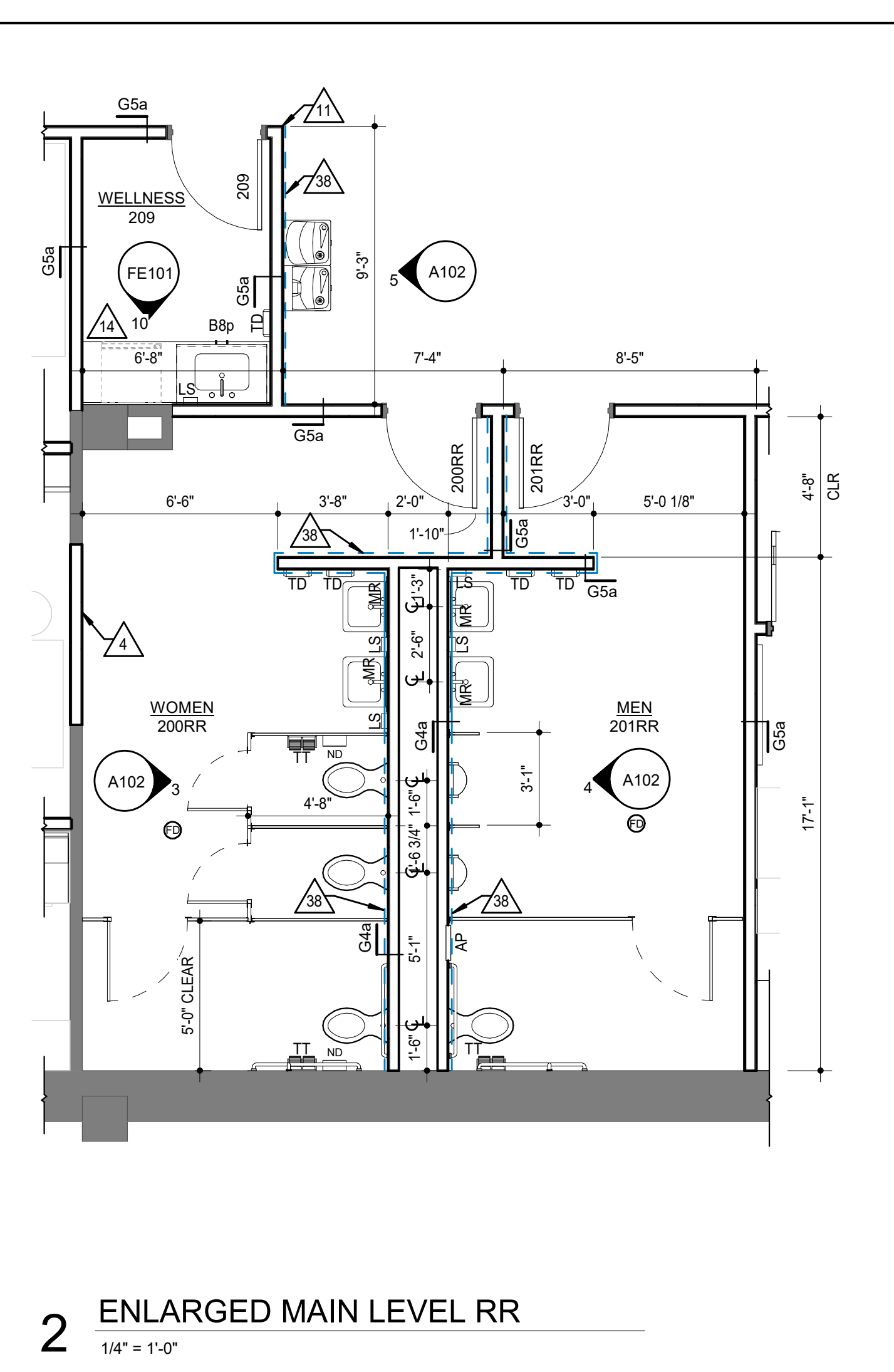
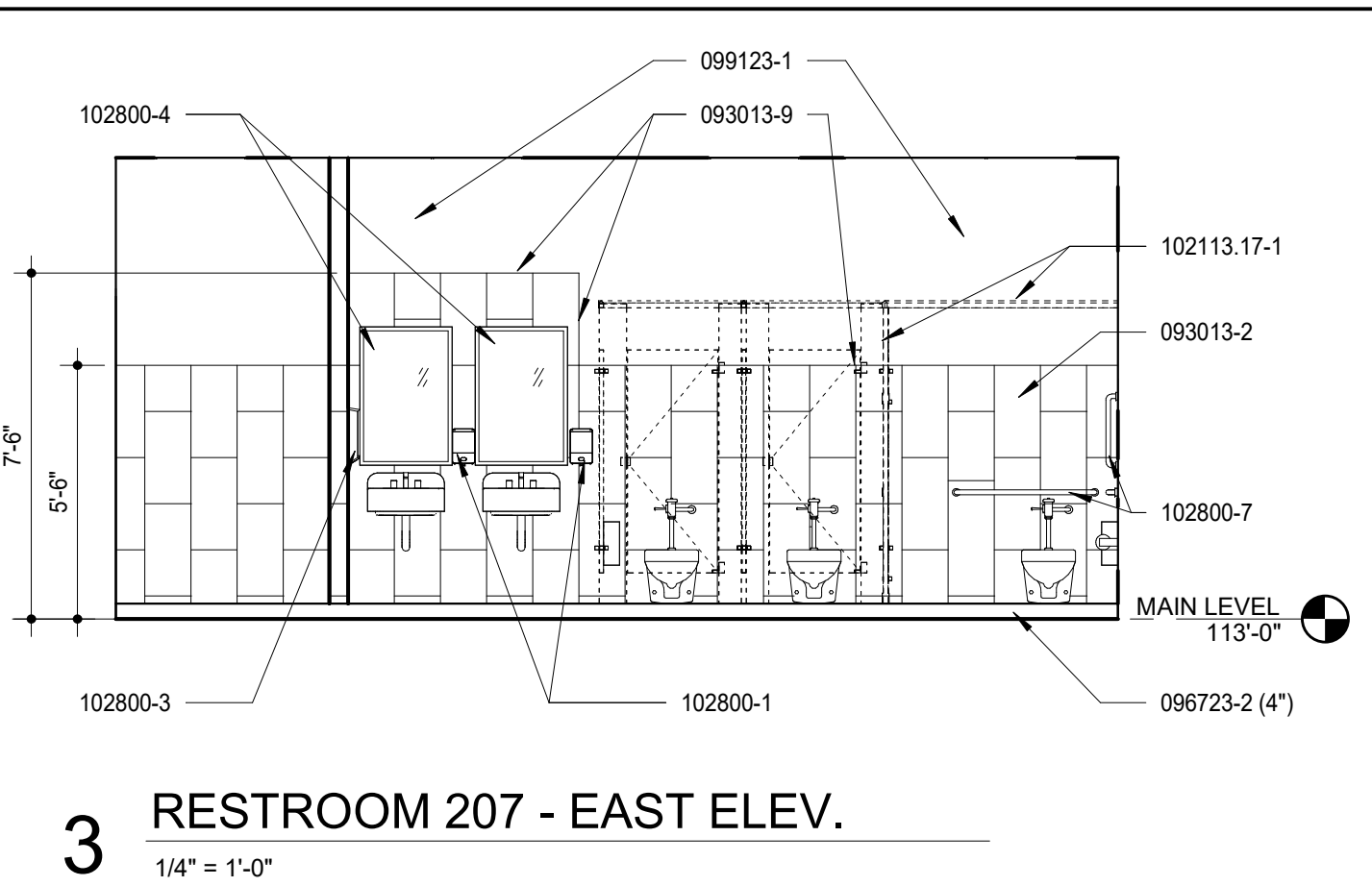

ARCHITECTURAL PLAN NOTES

- GENERAL: COORDINATE WITH WORK SHOWN ON MECHANICAL, PLUMBING, AND ELECTRICAL DRAWINGS
- 1 PROVIDE FIRE EXTINGUISHER CABINET; REF. 5/A301
 - 2 EXISTING FLOOR CHANGE TO REMAIN
 - 3 LEAD LINED GYP. BD. FOR 7' A.F.F.; LEAD GYP THICKNESS, LEAD WINDOW AND DOOR TO BE INCLUDED IN GC ALLOWANCE
 - 4 INFILL EXISTING WALL OPENING, PATCH TO MATCH ADJ. SURFACES FOR LIKE NEW APPEARANCE; PAINT WALL CORNER TO CORNER
 - 5 EXISTING COLUMN TO REMAIN; PROTECT
 - 6 EXISTING DOOR TO REMAIN; PROTECT
 - 7 PATCH WALL & PAINT CORNER TO CORNER
 - 8 PATCH CMU @ PLUMBING WORK; TOOTH IN MASONRY
 - 9 EXISTING ELECTRICAL PANEL TO REMAIN; PROTECT
 - 10 PATCH SLAB @ NEW PLUMBING IN EXISTING SLAB; REF. MEP & A100 FOR LOCATIONS
 - 11 CORNER GUARD; MOUNT ABOVE WALL BASE
 - 12 NOT USED
 - 13 SHELVED BY OWNER
 - 14 FURNITURE OR EQUIPMENT BY OWNER
 - 15 MANUAL ROLLER SHADE
 - 16 SOLID SURFACE COUNTERTOP
 - 17 SKIM COAT EXISTING COLUMNS W/ DRYWALL COMPOUND
 - 18 PATCH FLOORING WITH EXISTING CARPET TILE
 - 19 EXISTING CASEWORK TO REMAIN; PROTECT
 - 20 PATCH FLOORING & WALL @ WALL DEMO
 - 21 NOT USED
 - 22 PATCH WALL @ EXISTING WALL REMOVAL
 - 23 IT EQUIPMENT TO REMAIN
 - 24 PROVIDE FIRE EXTINGUISHER CABINET; REF. A302
 - 25 METAL LAB CASEWORK
 - 26 EXISTING PIPING TO REMAIN; PROTECT
 - 27 STAINLESS STEEL COUNTERTOP
 - 28 ROOM OCCUPIED THROUGHOUT CONSTRUCTION FOR CAMPUS MAIL SERVICE. MAINTAIN OPERATION & ACCESS FROM OUTSIDE
 - 29 PROVIDE DRINKING FOUNTAIN; REF. MEP
 - 30 WINDOW WELL TO REMAIN
 - 31 MANUAL BLACKOUT SHADE
 - 32 AREA OF FLOOR FILL; REF. DETAIL ON A301
 - 33 DIMENSIONAL LETTER SIGNAGE
 - 34 PROVIDE BLOCKING FOR OWNER PROVIDED EQUIPMENT
 - 35 NEW G5a WALL BY ALT.
 - 36 ROOM SCHEDULER; REF. MEP
 - 37 HEAD WALL REMOVED FROM EXISTING LOCATION; REINSTALL IN NEW LOCATION
 - 38 GLAZED WALL TILE TO 5'-6" AFF. U.N.O. REF. RESTROOM ELEVATIONS A101
 - 39 CUSTOM WALL GRAPHIC BY ALT.; REF. ELEVATIONS A801. PATCH WALL AND PROVIDE LEVEL 5 GYP. BD. FINISH. PATCH WALL AND PROVIDE LEVEL 5 GYP. BD. FINISH. PATCH PATCH CHASE AT NEW MEP WORK
 - 40 CARD READER; REF. MEP
 - 41 CONCRETE STOOP REF. DTL.
 - 42 PROVIDE DIAPER CHANGING STATION 102800-14

TOILET ACCESSORIES LEGEND

ABB	DESCRIPTION
LS	WALL MTD. LIQUID SOAP DISP. PROVIDE ONE PER LAVATORY/ SINK 102800-1
FD	FLOOR DRAIN; REF. MECH.
ND	SANITARY NAPKIN DISPOSER 102800-6
TT	TOILET TISSUE DISPENSER 102800-2
BCT	DIAPER CHANGING TABLE 102800-14
MR	MIRROR 102800-4
AP	ACCESS PANEL (24"W X 36"H) 083113-1 & -2
TD	TOWEL DISPENSER PROVIDE ONE PER LAVATORY/ SINK 102800-3
GB	GRAB BARS 102800-7

NOTES:
REFER TO SECTIONS AND DETAILS ON ALL OTHER SHEETS FOR APPLICABLE NOTES NOT SHOWN.



DATE: July 16, 2024
REVISED DATE:



DATE:
 July 16, 2024

REVISED DATE:

MABEE LIBRARY RENOVATION

Washburn University
 1800 SW 19th Street, Topeka, KS 66621

SHEET CONTENTS:
 ARCHITECTURAL FLOOR PLAN - UPPER LEVEL

HTK PROJECT NUMBER:
 2312.03

SHEET NUMBER:
A103

ORIGINAL CONTRACT DOCUMENTS

ARCHITECTURAL PLAN NOTES

- GENERAL: COORDINATE WITH WORK SHOWN ON MECHANICAL, PLUMBING, AND ELECTRICAL DRAWINGS
- 1 PROVIDE FIRE EXTINGUISHER CABINET; REF. 5/A301
 - 2 EXISTING FLOOR CHANGE TO REMAIN
 - 3 LEAD LINED GYP. BD. FOR 7' A.F.F.; LEAD GYP THICKNESS, LEAD WINDOW AND DOOR TO BE INCLUDED IN GC ALLOWANCE
 - 4 INFILL EXISTING WALL OPENING; PATCH TO MATCH ADJ. SURFACES FOR LIKE NEW APPEARANCE; PAINT WALL CORNER TO CORNER
 - 5 EXISTING COLUMN TO REMAIN; PROTECT
 - 6 EXISTING DOOR TO REMAIN; PROTECT
 - 7 PATCH WALL & PAINT CORNER TO CORNER
 - 8 PATCH CMU @ PLUMBING WORK; TOOTH IN MASONRY
 - 9 EXISTING ELECTRICAL PANEL TO REMAIN; PROTECT
 - 10 PATCH SLAB @ NEW PLUMBING IN EXISTING SLAB; REF. MEP & A100 FOR LOCATIONS
 - 11 CORNER GUARD; MOUNT ABOVE WALL BASE
 - 12 NOT USED
 - 13 SHELVING BY OWNER
 - 14 FURNITURE OR EQUIPMENT BY OWNER
 - 15 MANUAL ROLLER SHADE
 - 16 SOLID SURFACE COUNTERTOP
 - 17 SKIM COAT EXISTING COLUMNS W/ DRYWALL COMPOUND
 - 18 PATCH FLOORING WITH EXISTING CARPET TILE
 - 19 EXISTING CASEWORK TO REMAIN; PROTECT
 - 20 PATCH FLOORING & WALL @ WALL DEMO
 - 21 NOT USED
 - 22 PATCH WALL @ EXISTING WALL REMOVAL
 - 23 IT EQUIPMENT TO REMAIN
 - 24 PROVIDE FIRE EXTINGUISHER CABINET; REF. A302
 - 25 METAL LAB CASEWORK
 - 26 EXISTING PIPING TO REMAIN; PROTECT
 - 27 STAINLESS STEEL COUNTERTOP
 - 28 ROOM OCCUPIED THROUGHOUT CONSTRUCTION FOR CAMPUS MAIL SERVICE. MAINTAIN OPERATION & ACCESS FROM OUTSIDE
 - 29 PROVIDE DRINKING FOUNTAIN; REF. MEP
 - 30 WINDOW WELL TO REMAIN
 - 31 MANUAL BLACKOUT SHADE
 - 32 AREA OF FLOOR FILL; REF. DETAIL ON A301
 - 33 DIMENSIONAL LETTER SIGNAGE
 - 34 PROVIDE BLOCKING FOR OWNER PROVIDED EQUIPMENT
 - 35 NEW G5a Wall by ALT.
 - 36 ROOM SCHEDULER; REF. MEP
 - 37 HEAD WALL. REMOVED FROM EXISTING LOCATION. REINSTALL IN NEW LOCATION
 - 38 GLAZED WALL TILE TO 5'-6" AFF. U.N.O. REF. RESTROOM ELEVATIONS A101
 - 39 CUSTOM WALL GRAPHIC BY ALT.; REF. ELEVATIONS A801; PATCH WALL AND PROVIDE LEVEL 5 GYP. BD. FINISH. PATCH WALL AND PROVIDE LEVEL 5 GYP. BD. FINISH
 - 40 PATCH CHASE AT NEW MEP WORK
 - 41 CARD READER; REF. MEP
 - 42 CONCRETE STOOP REF. DTL.
 - 43 PROVIDE DIAPER CHANGING STATION 102800-14

NOTES:
 REFER TO SECTIONS AND DETAILS ON ALL OTHER SHEETS FOR APPLICABLE NOTES NOT SHOWN.

ROOM FINISH SCHEDULE - UPPER LEVEL

ROOM MARK	ROOM NAME	FLOOR	BASE	WALLS				NOTES
				NORTH	EAST	SOUTH	WEST	
301	RECEP	CPT	RB	LPT	LPT	LPT	LPT	
301A	OFF	CPT	RB	LPT	LPT	LPT	LPT	
301B	OFF	CPT	RB	LPT	LPT	LPT	LPT	
301C	OFF	CPT	RB	LPT	LPT	LPT	LPT	
301D	OFF	CPT	RB	LPT	LPT	LPT	LPT	
301E	OFF	CPT	RB	LPT	LPT	LPT	LPT	
301F	STOR	CPT	RB	LPT	LPT	LPT	LPT	
301G	OFF	CPT	RB	LPT	LPT	LPT	LPT	
301H	OFF	CPT	RB	LPT	LPT	LPT	LPT	
301H1	HALL	CPT	RB	LPT	LPT	LPT	LPT	
301I	OFF	CPT	RB	LPT	LPT	LPT	LPT	
301K	OFF	CPT	RB	LPT	LPT	LPT	LPT	
301L	OFF	CPT	RB	LPT	LPT	LPT	LPT	
302	MED CLRM	CPT/EXIST	RB/EXIST	LPT	LPT	LPT	LPT	
305	WKRM	CPT	RB	LPT	LPT	LPT	LPT	
306	CONF	CPT	RB	LPT	LPT	LPT	LPT	
306A	STOR	CPT	RB	LPT	LPT	LPT	LPT	
307	RECEP	CPT	RB	LPT	LPT	LPT	LPT	
307B	OFF	CPT	RB	LPT	LPT	LPT	LPT	
307C	OFF	CPT	RB	LPT	LPT	LPT	LPT	
307D	OFF	CPT	RB	LPT	LPT	LPT	LPT	
307E	HALL	CPT	RB	LPT	LPT	LPT	LPT	
308	DEAN	CPT	RB	LPT	LPT	LPT	LPT	
309	RECEP	CPT	RB	LPT	LPT	LPT	LPT	
309A	OFF	CPT	RB	LPT	LPT	LPT	LPT	
309B	OFF	CPT	RB	LPT	LPT	LPT	LPT	
309C	OFF	CPT	RB	LPT	LPT	LPT	LPT	
309D	OFF	CPT	RB	LPT	LPT	LPT	LPT	
309E	OFF	CPT	RB	LPT	LPT	LPT	LPT	
309F	OFF	CPT	RB	LPT	LPT	LPT	LPT	
309G	STOR	CPT	RB	LPT	LPT	LPT	LPT	
309H	OFF	CPT	RB	LPT	LPT	LPT	LPT	
309H1	HALL	CPT	RB	LPT	LPT	LPT	LPT	
309J	OFF	CPT	RB	LPT	LPT	LPT	LPT	
309K	OFF	CPT	RB	LPT	LPT	LPT	LPT	
309L	OFF	CPT	RB	LPT	LPT	LPT	LPT	
309M	OFF	CPT	RB	LPT	LPT	LPT	LPT	
310	OFF	CPT	RB	LPT	LPT	LPT	LPT	
311	CONF	CPT	RB	LPT	LPT	LPT	LPT	
311A	STOR	CPT	RB	LPT	LPT	LPT	LPT	
312	MED CLRM	CPT	RB	LPT	LPT	LPT	LPT	
313	MED CLRM	CPT	RB	LPT	LPT	LPT	LPT	
331	FLEX	CPT/EXIST	RB	LPT	EXIST	EPT	EPT	

ROOM FINISH SCHEDULE LEGEND

- FLOOR**
 EXIST NO NEW FINISH; EXISTING TO REMAIN
 SC SEALED CONCRETE
 VCT VINYL COMPOSITION TILE
 PT PORCELAIN TILE
 CPT CARPET TILE
 RES RESINOUS FLOORING
 RTR RUBBER TREADS AND RISERS
 WOM WALK-OFF MAT
- WALL BASE**
 EXIST NO NEW FINISH; EXISTING TO REMAIN
 RB RESILIENT BASE (4" HIGH)
 RES EPOXY COVE BASE
- WALLS**
 EXIST NO NEW FINISH; EXISTING TO REMAIN
 LPT LATEX PAINT
 EPT EPOXY PAINT
 PWT PORCELAIN WALL TILE
 CT CERAMIC TILE
- NOTES**
 1. PROVIDE NEW FINISHES AT NEW WALLS, PATCH EXISTING WALLS AND FINISHES AS REQUIRED
 2. WALL BASE AT NEW WALL
 3. PAINT & WALL BASE IF ALTERNATE FOR NEW WALL IS ACCEPTED

PAINT LEGEND

- PAINT WALL**
 # 1/2" PAINT COLOR
 # 1/4" PAINT COLOR
- PAINT OVERHEAD**
 # 1/2" PAINT COLOR
 # 1/4" PAINT COLOR
- PAINT ACCENT:**
 # 1 PAINT 1 (FIELD WHITE)
 MFR: BENJAMIN MOORE
 COLOR: SPRING THAW
 # 2 PAINT 2 (ACCENT)
 MFR: BENJAMIN MOORE
 COLOR: IN THE NAVY
 # 3 PAINT 3 (FRAME & TRIM COLOR)
 MFR: BENJAMIN MOORE
 COLOR: MATCH EXISTING
- GENERAL PAINT NOTES:**
 1. UNLESS NOTED OTHERWISE, USE PAINT 1 (FIELD COLOR)
 2. ALL DOOR FRAMES, RAILINGS, MECHANICAL GRILLS THAT WERE PREVIOUSLY PAINTED, & TRIM ARE TO BE PAINTED PAINT 3, U.N.O.



1 ARCHITECTURAL FLOOR PLAN - UPPER LEVEL
 1/8" = 1'-0"



DATE: July 16, 2024
 REVISED DATE:

KEYNOTES	
NOTE: KEYNOTES ARE DRAWN FROM A MASTER LIST AND MAY NOT BE SEQUENTIALLY NUMBERED. SIZES (EX. 24") OR OTHER INFO FOLLOWING KEYNOTE ON DRAWINGS INDICATES CRITERIA FOR THOSE MATERIALS/ LOCATIONS WHICH MAY DIFFER FROM THE STD. MATERIAL SPECIFIED.	
033000-1 CONCRETE	082900-1 GYPSUM BOARD (")
-2 CONCRETE FLOOR SLAB	-2 FIRE RATED GYPSUM BOARD (")
-3 VAPOR BARRIER	-3 GEMENTIOUS TILE BACKER PANEL
-4 WELDED WIRE FABRIC	-4 METAL SUSPENSION SYSTEM
055000-1 STEEL ANGLE	-5 ACUSTICAL SEALANT
-5 STEEL REINFORCING BAR	-6 METAL SUSPENSION SYSTEM
-6 STEEL ANGLE	-7 METAL EDGE TRIM
-7 STEEL LINTEL	-8 ACUSTICAL INSULATION(")
-8 STEEL PLATE	-9 METAL EDGE TRIM
061000-2 2X WOOD BLOCKING (")	-10 AUXILIARY SUPPORT FRAMING
-3 FLYWOOD BACKER	-10 HIGH IMPACT GYPSUM BOARD
064116-1 PLASTIC LAMINATE-FACED ARCHITECTURAL CABINETS	-11 INTERIOR FINISHING COMPOUND
083013-2 GLAZED WALL TILE (")	-12 PORCELAIN FLOOR TILE (")
-3 CABINET LINER LAMINATE	-13 FLYWOOD
-4 3MM EDGE MOLDING	-14 METAL EDGE STRIP (")
-5 DOOR HINGE	086113-1 ACUSTICAL PANEL (")
-6 DOOR/DRAWER PULL	-2 CEILING SUSPENSION SYSTEM
-7 MAGNETIC CATCH	-3 EDGE MOLD TRIM
-8 DRAWER	-4 AUXILIARY SUPPORT FRAMING
-9 SHELF SUPPORTS	096513-1 RESILIENT WALL BASE
-10 COUNTERTOP SUPPORT	096513-2 EDGE STRIP
-11 BRACKET	096513-3 RESILIENT SHEET FLOORING
072100-4 BUILDING INSULATION-BRACKET	096513-4 RESILIENT FLOOR TILE
-12 MAGNETIC CATCH	-5 CARPET TILE
-13 DRAWER	09813-1 WALL COVERING
-14 SHELF SUPPORTS	09813-2 INTERIOR PAINT
-15 COUNTERTOP SUPPORT	101100-1 MANAGERBOARD
072100-4 BUILDING INSULATION-BRACKET	101100-2 TACKBOARD
-16 SAFING INSULATION	101400-1 DIMENSIONAL LETTER SIGNAGE
078200-1 SHEET METAL FLASHING AND COUNTERFLASHING	101400-2 PHENOLIC CORE TOILET COMPARTMENT
079200-1 JOINT SEALANT - RAKE	102600-1 CORNER GUARD
-2 JOINT FILLER	102600-2 FRIP IMPACT-RESISTANT WALL COVERING
-3 BACKER ROD	102600-3 SCAP DISPENSER
081113-2 HOLLOW METAL FRAME	-4 TOILET TISSUE DISPENSER
-3 FRAME ANCHOR	102600-1 PAPER TOWEL DISPENSER
081416-1 FLUSH WOOD DOOR	-5 FRAMED MIRROR
083113-1 ACCESS DOOR	-6 SANITARY NAPKIN DISPOSER
-2 ACCESS DOOR FRAME	-7 GRAB BAR
084113-1 ALUMINUM ENTRANCE DOOR	-8 DIAPER CHANGING STATION
-2 ALUMINUM STOREFRONT FRAME	104413-1 FIRE EXTINGUISHER CABINET
088900-1 GLAZING (AS SCHEDULED)	122413-1 METAL LABORATORY CASEWORK
092216-1 STEEL STUD (")	122413-2 ROLLER WINDOW SHADES
-2 STEEL STUD RUNNER (")	123553-1 SOLID SURFACE COUNTERTOP
-3 FURRING CHANNEL	134900-1 LEAD LINED GYP. BD.
	134900-2 LEAD GLASS
	134900-3 HOLLOW METAL FRAME
	134900-4 LEAD LINED WOOD DOOR

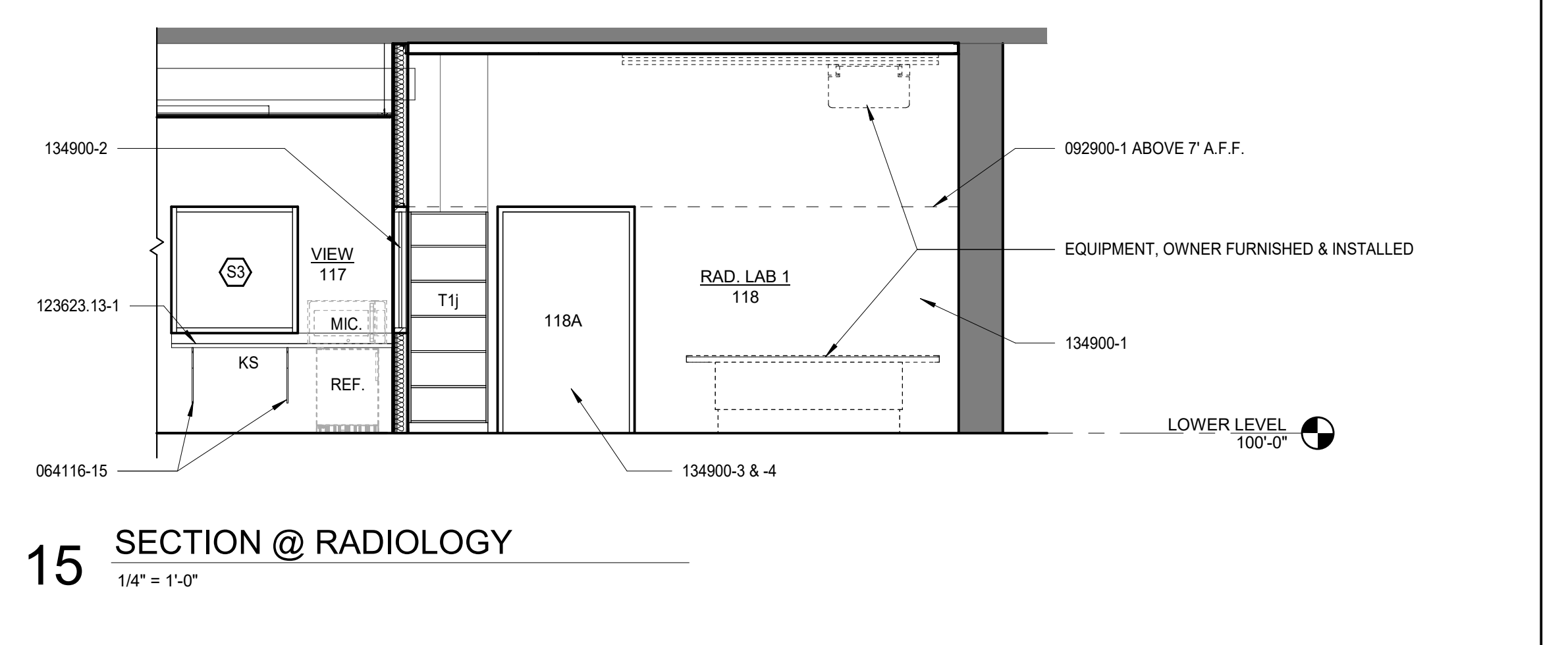
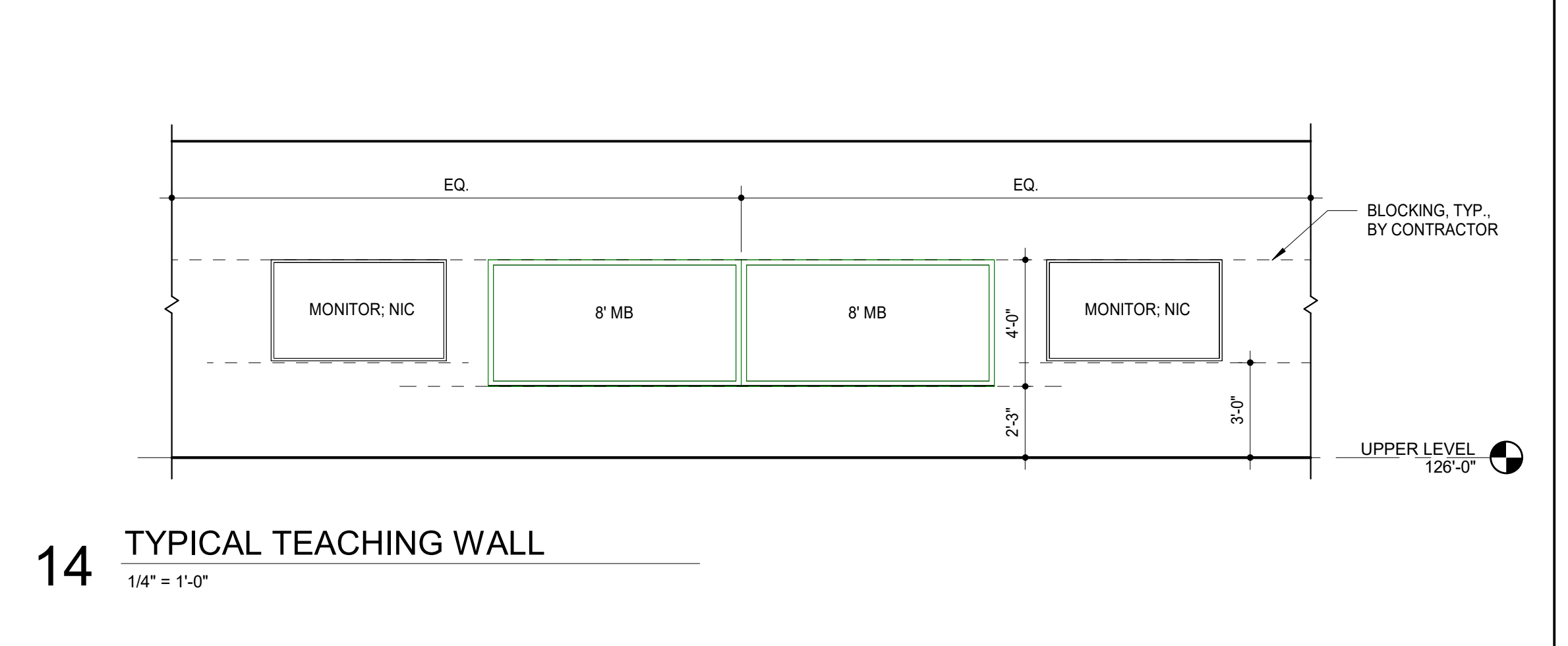
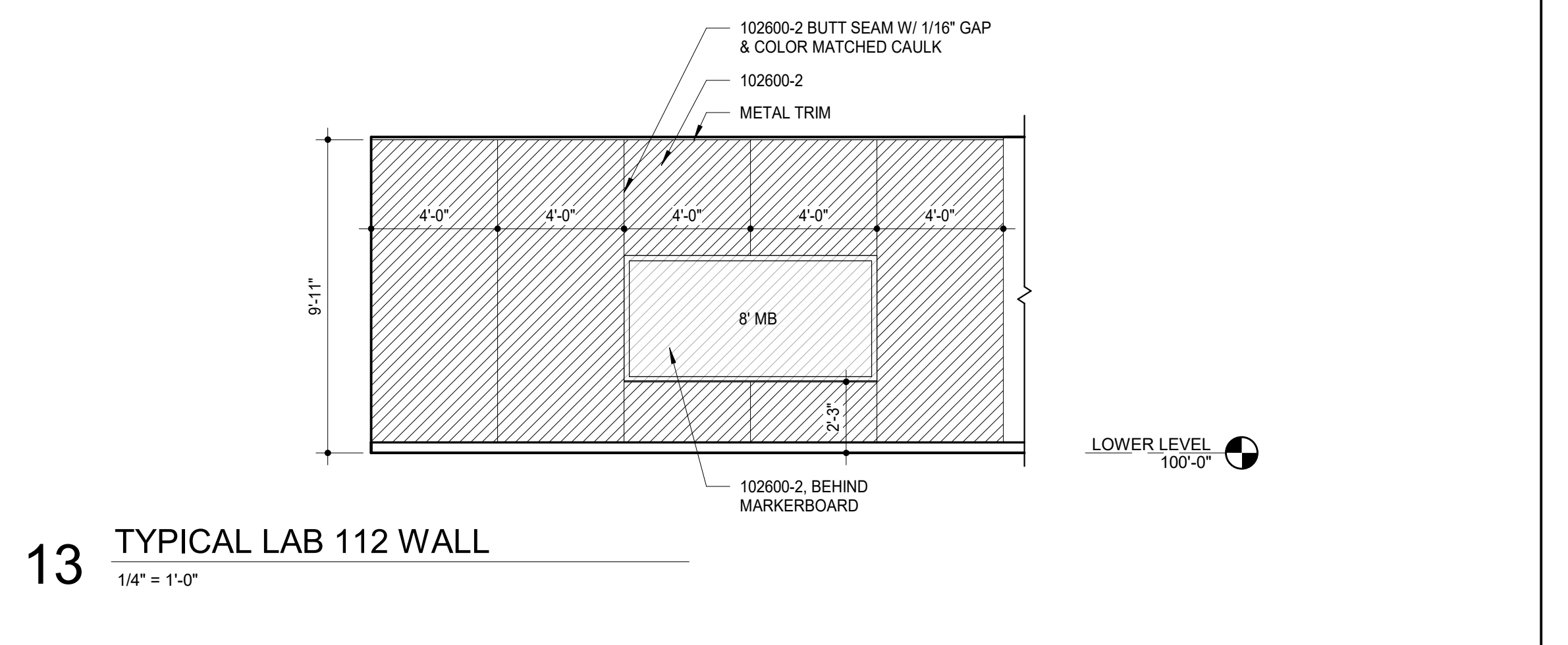
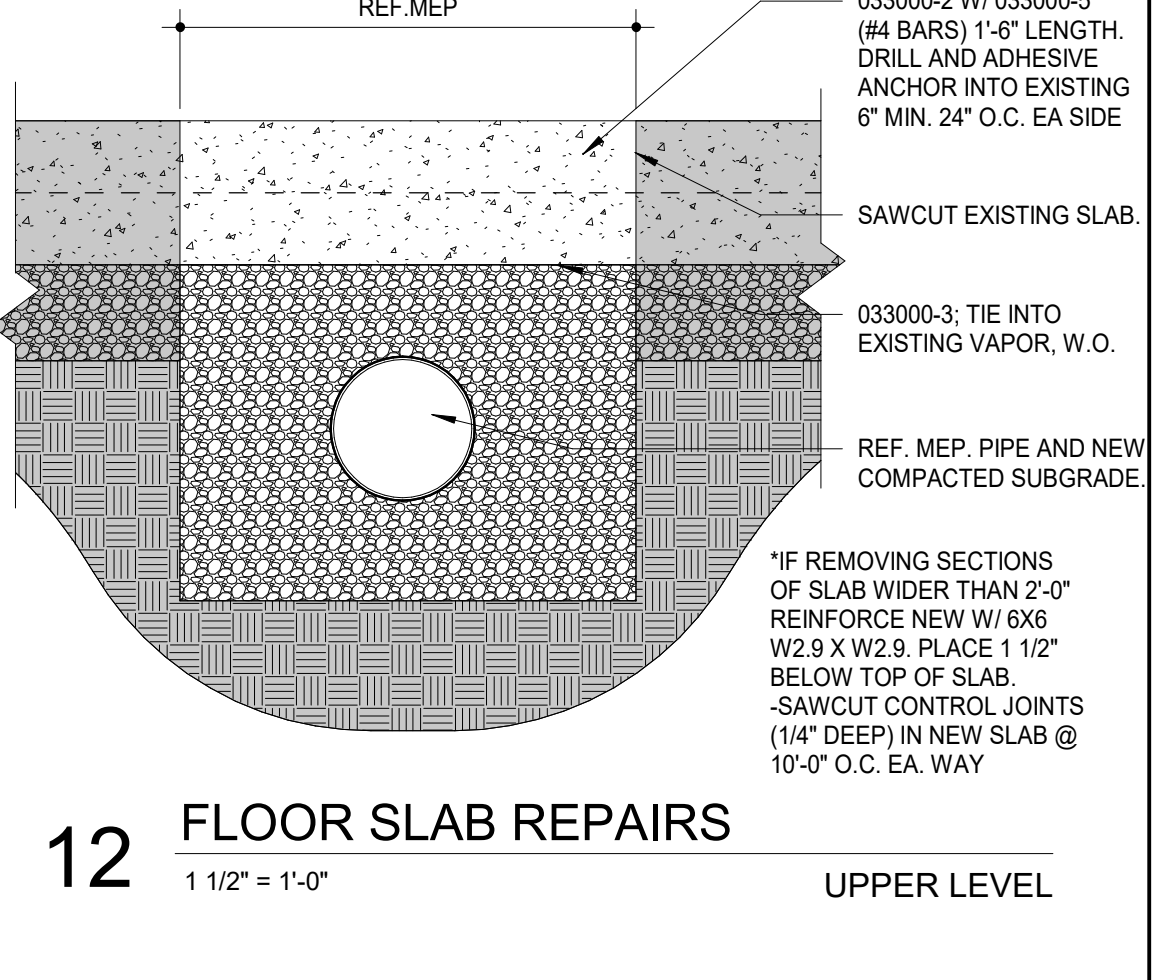
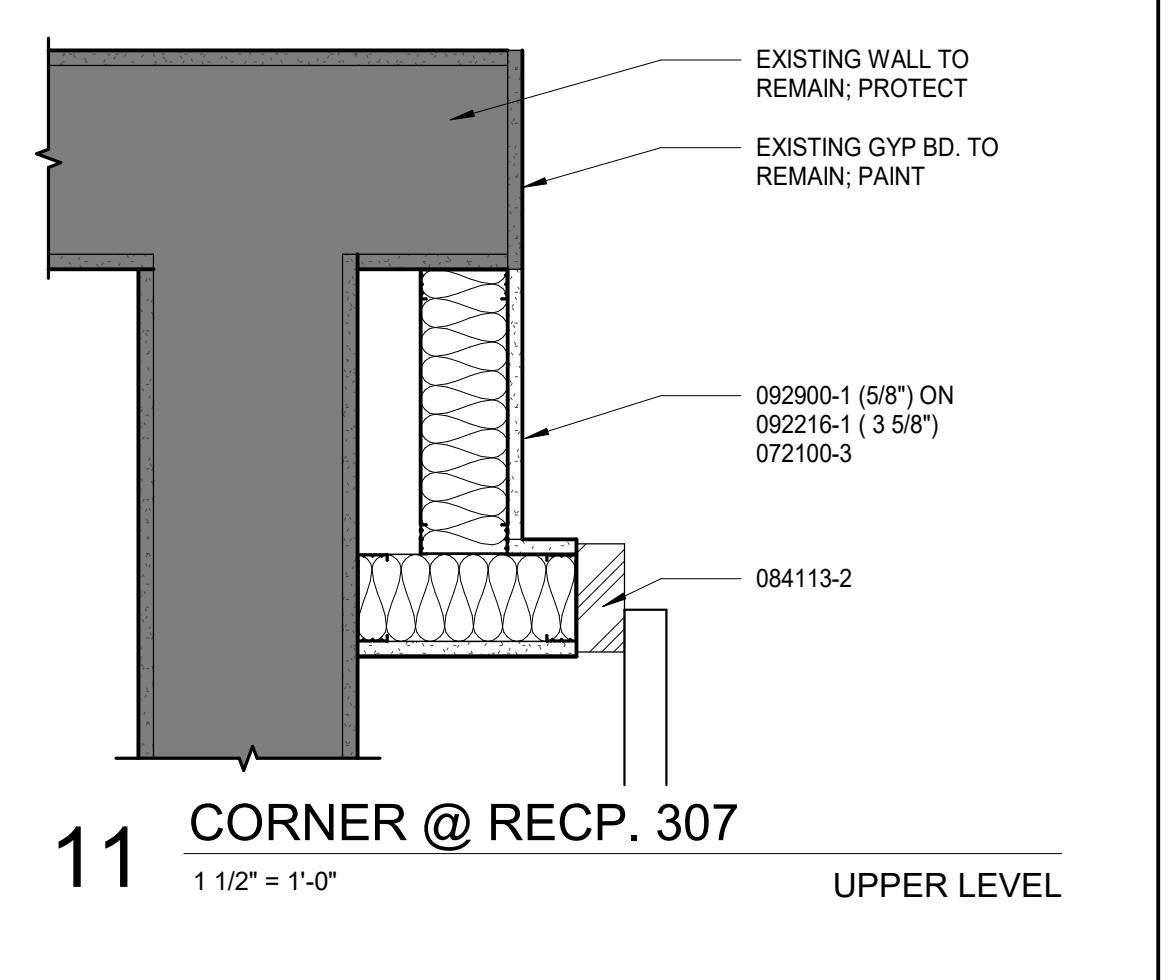
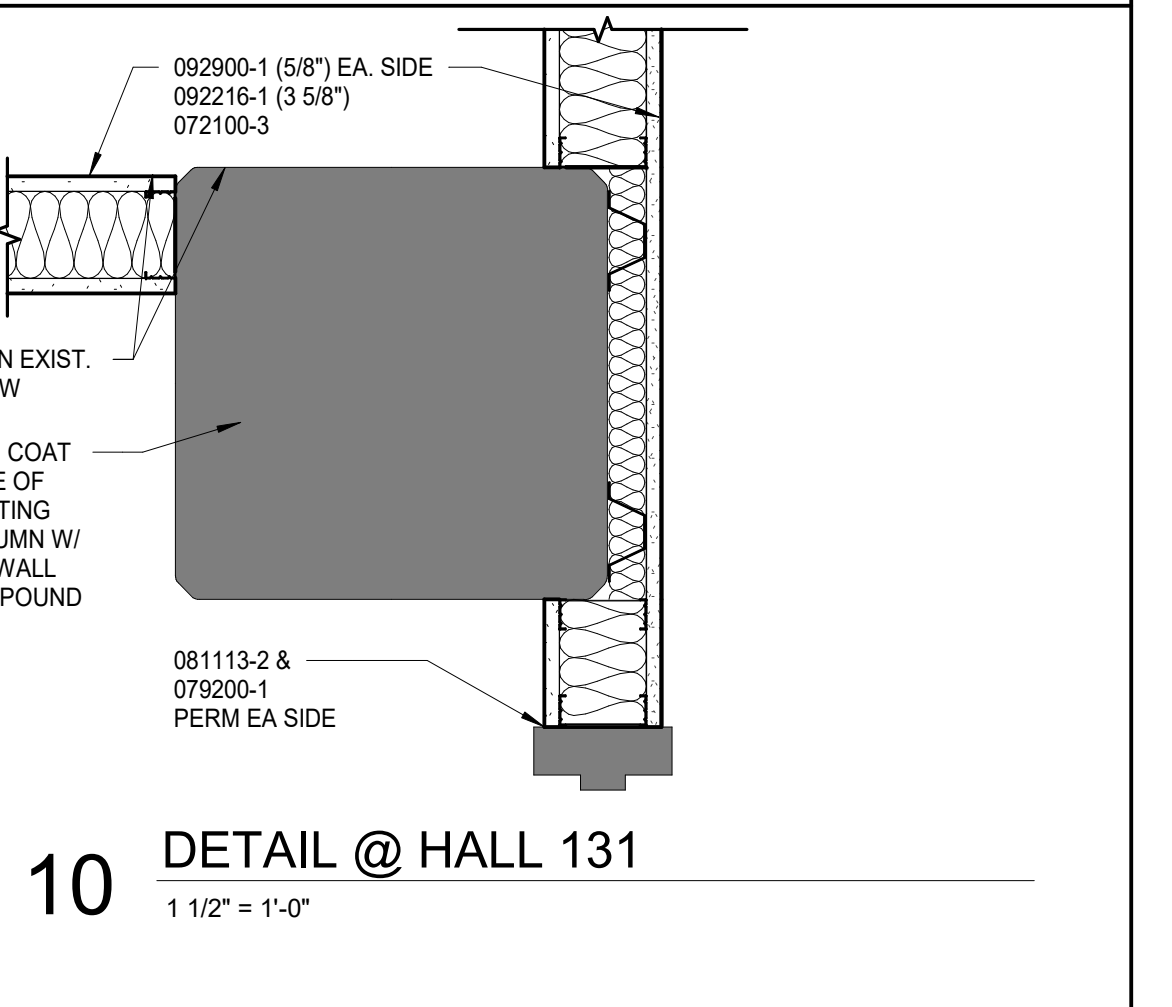
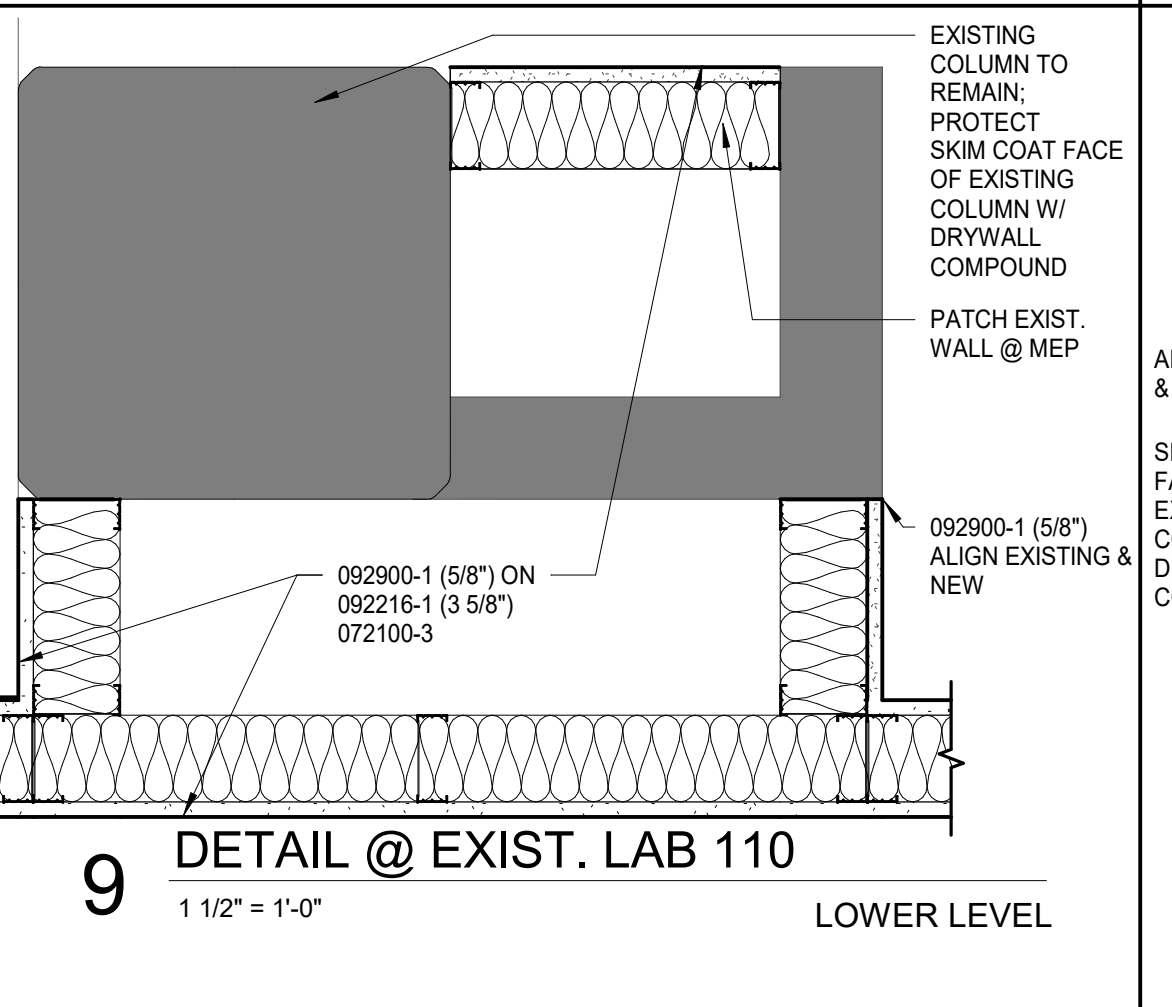
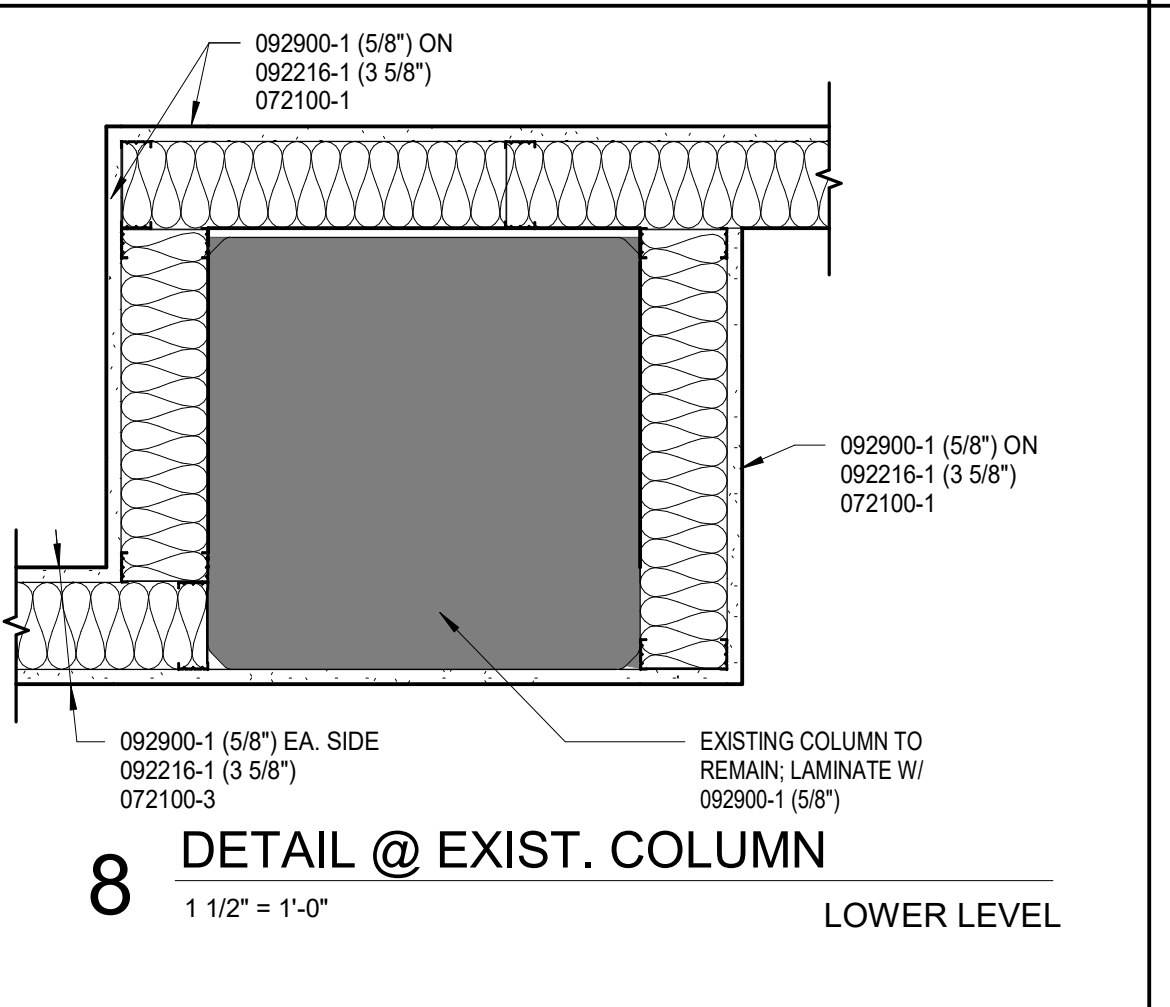
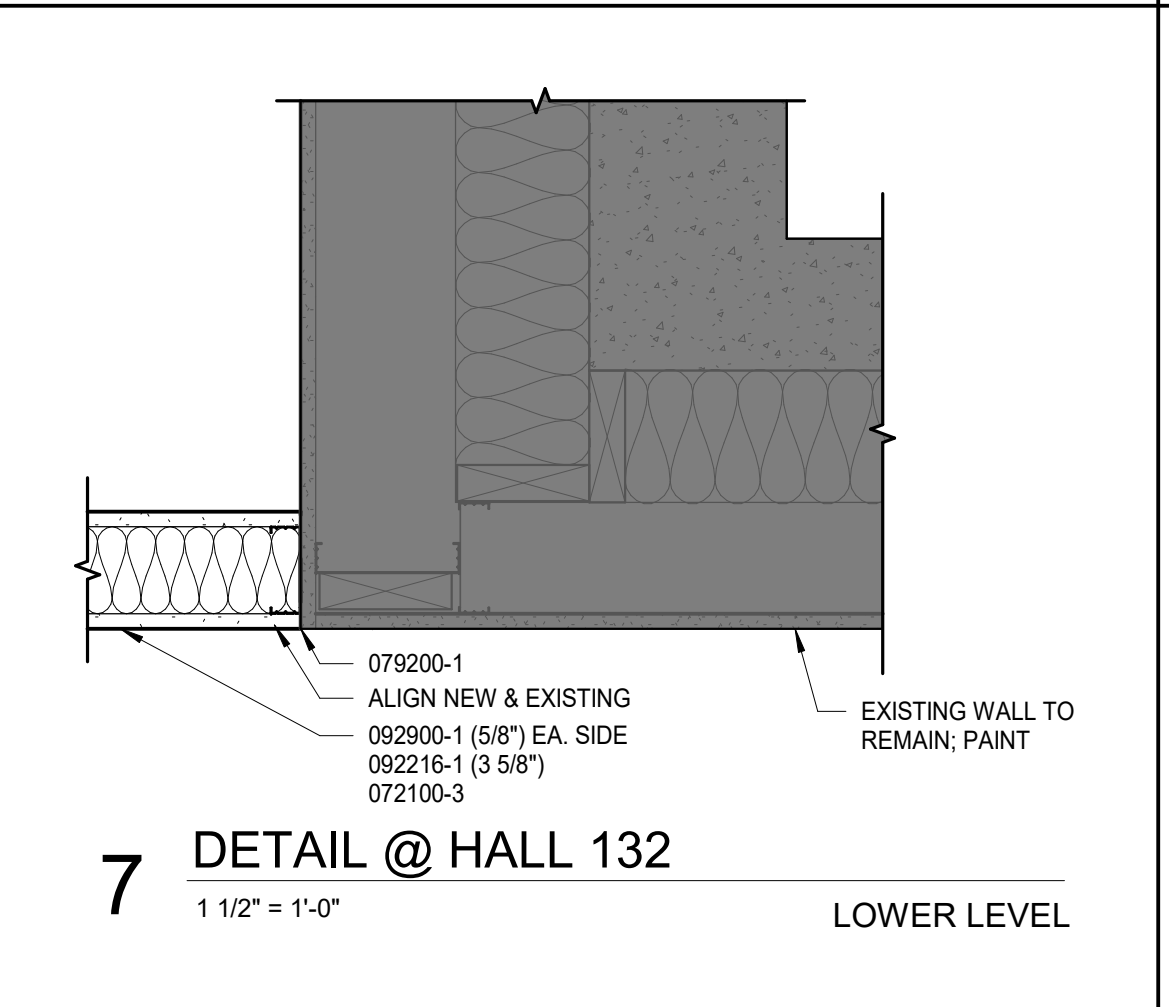
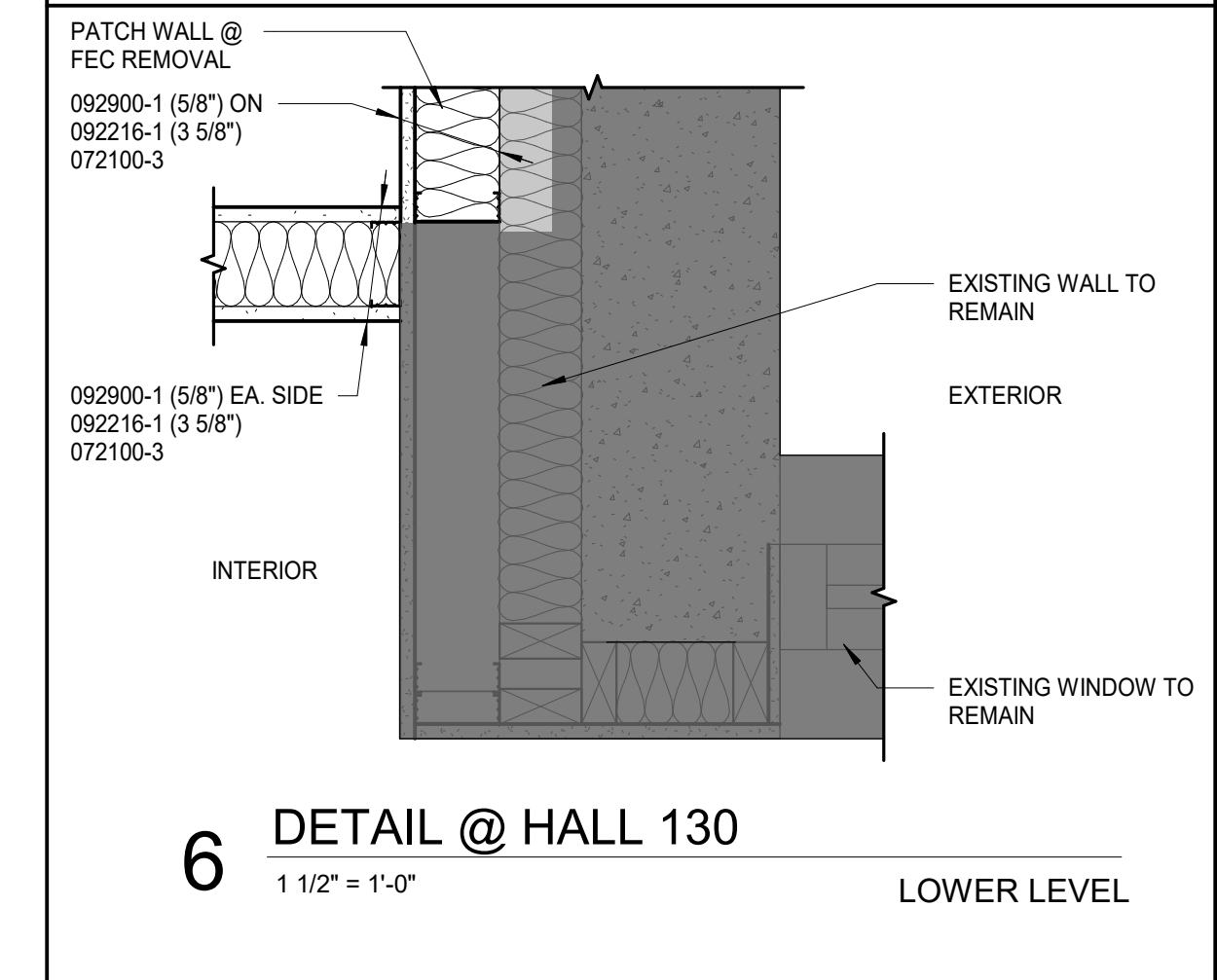
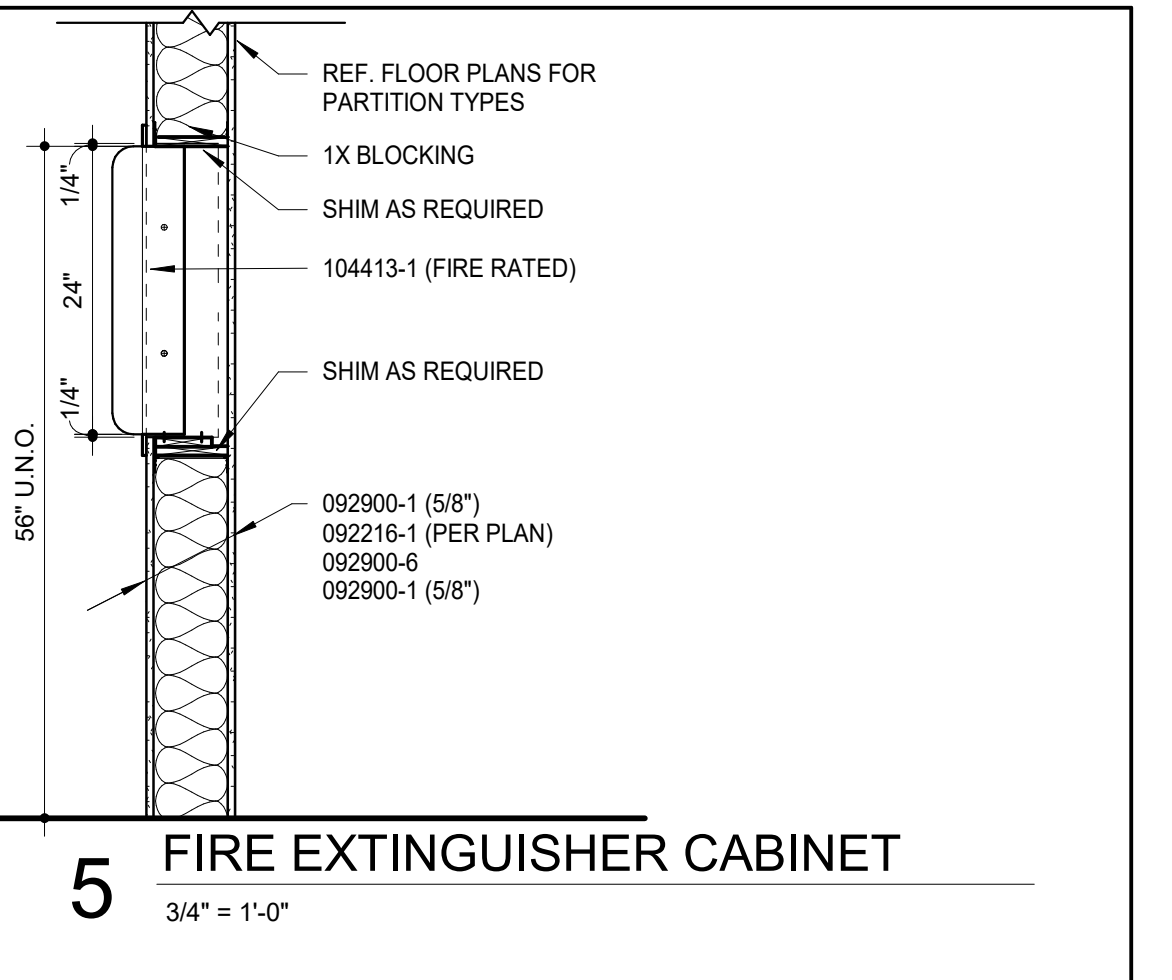
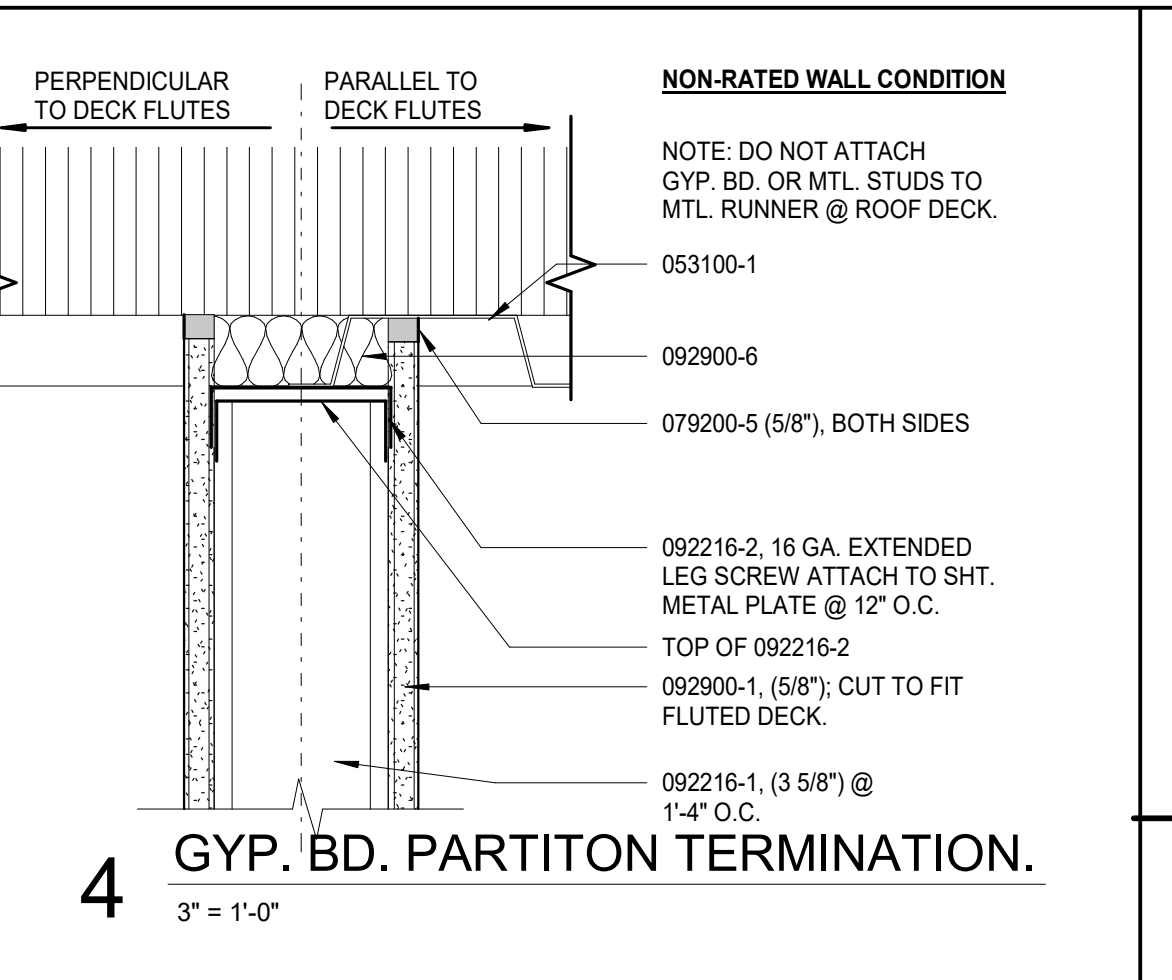
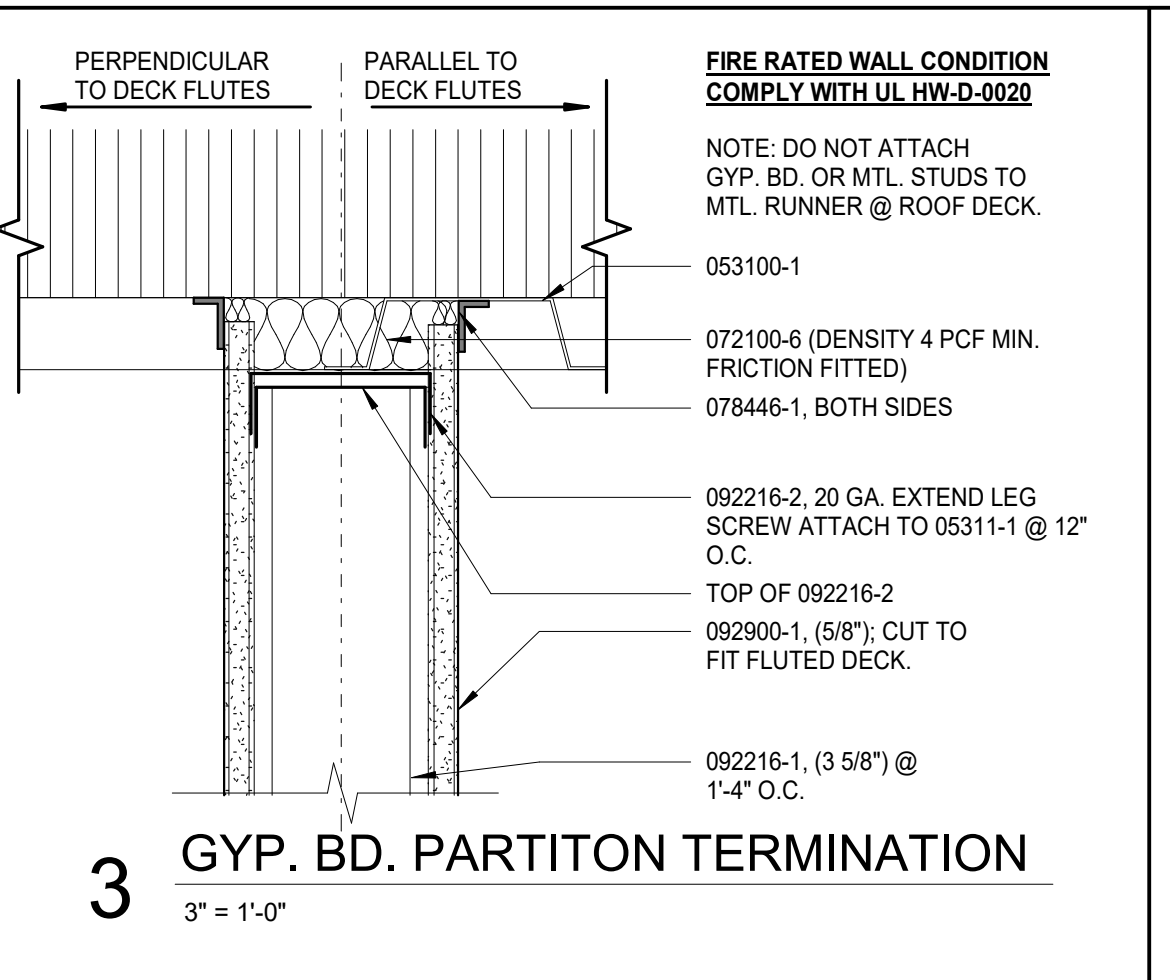
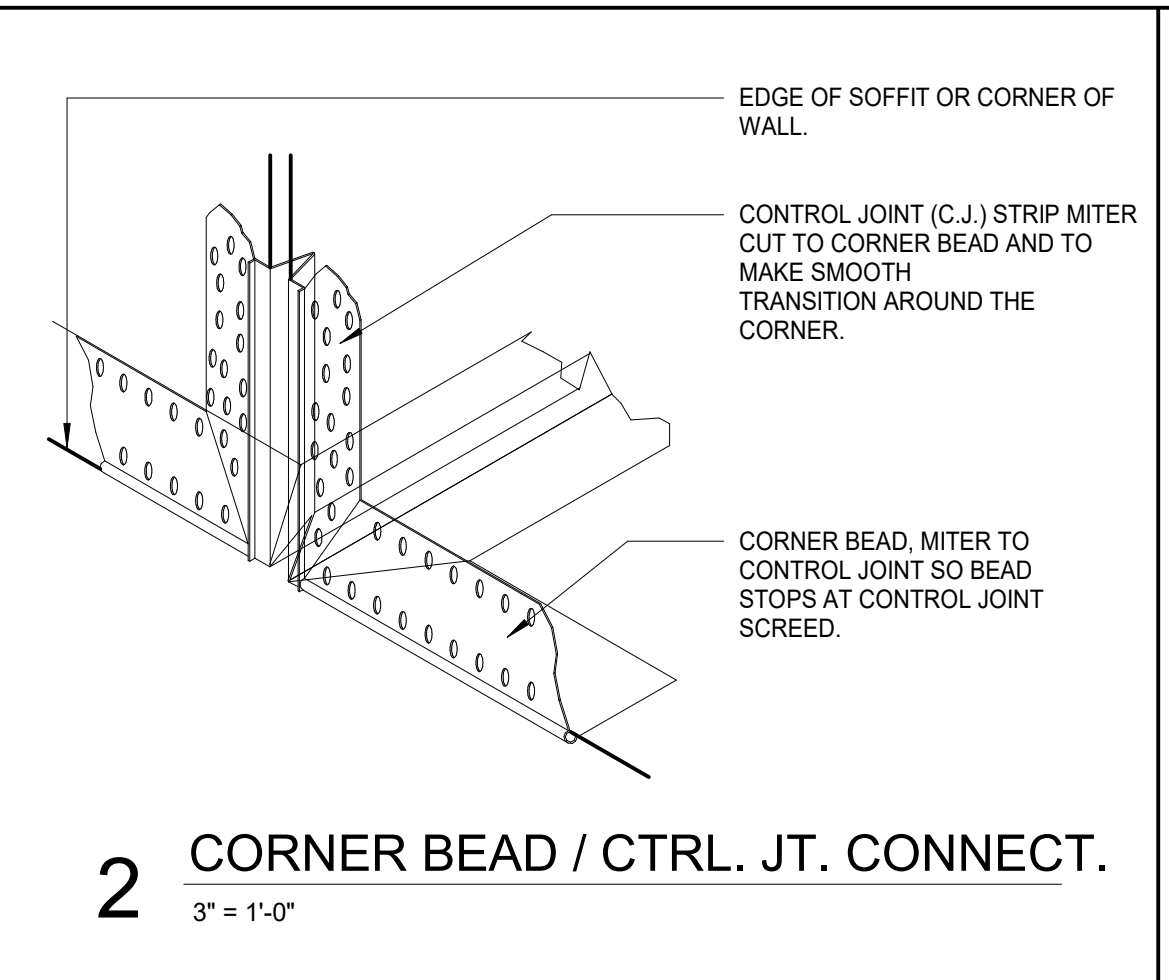
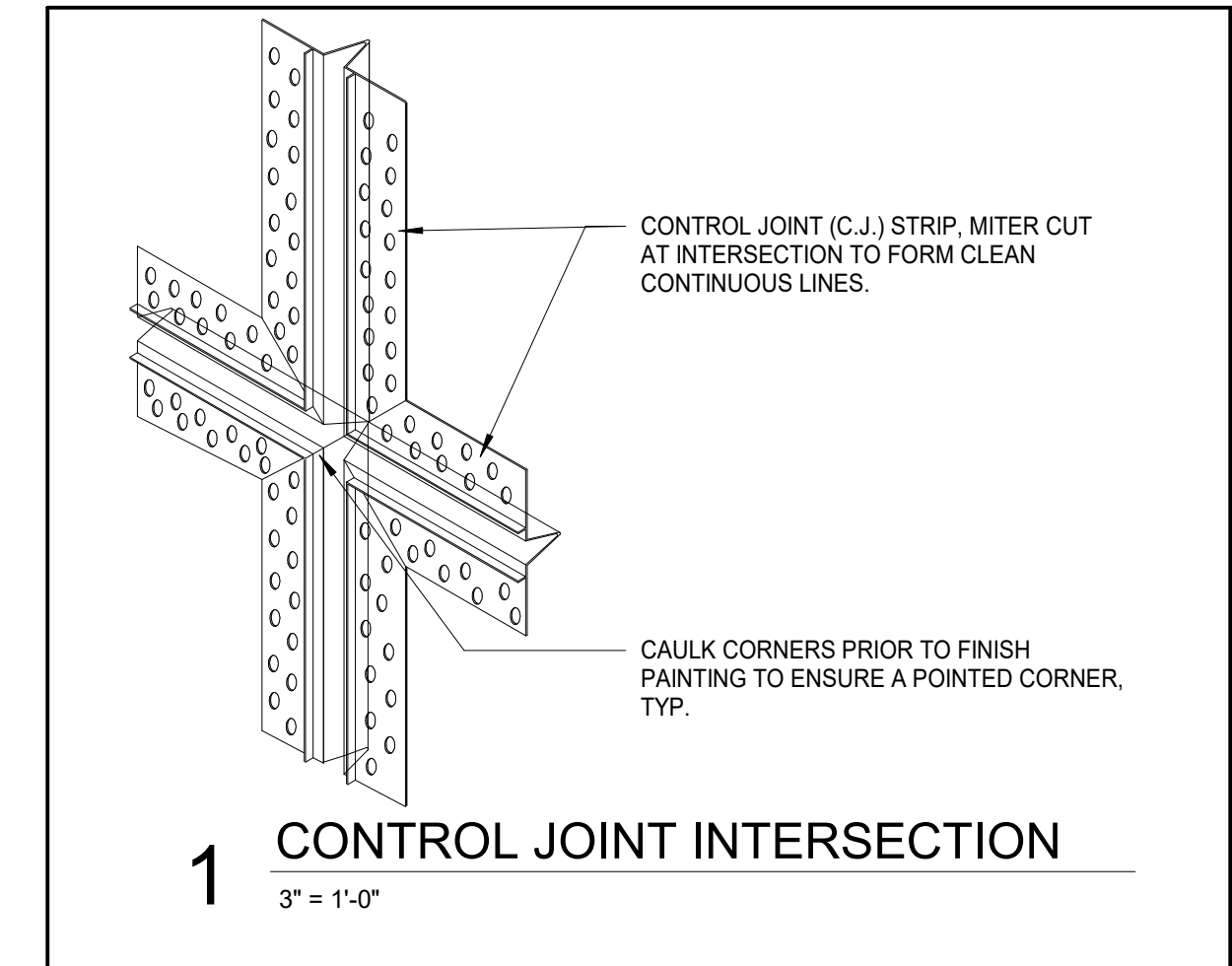

NOTES:
 REFER TO SECTIONS AND DETAILS ON ALL OTHER SHEETS FOR APPLICABLE NOTES NOT SHOWN.



DATE: July 16, 2024
 REVISED DATE:

MABEE LIBRARY RENOVATION
 Washburn University
 1800 SW 19th Street, Topeka, KS 66621

SHEET CONTENTS:
 ROOF PLAN & DETAILS
 HTK PROJECT NUMBER:
 2312.03
 SHEET NUMBER:
A401
 ORIGINAL CONTRACT DOCUMENTS

ROOF PLAN NOTES

GENERAL: COORDINATE WITH WORK SHOWN ON MECHANICAL, PLUMBING, AND ELECTRICAL DRAWINGS

- 1 NEW ROOF PENETRATION, PATCH AS REQ'D. EXISTING ROOF IS BELIEVED TO BE TAMKO, MODIFIED BITUMEN, NOT IN WARRANTY
- 2 NEW RTU; REF MEP
- 3 RTU RAILS AS REQ'D FOR NEW RTU; REF MEP
- 4 EXISTING ROOF TO REMAIN; NO WORK
- 5 ROOF ACCESS VIA STAIRS
- 6 EXISTING ROOF DRAIN TO REMAIN
- 7 EXISTING FLOOR GRATE TO REMAIN

KEYNOTES

NOTE: KEYNOTES ARE DRAWN FROM A MASTER LIST AND MAY NOT BE SEQUENTIALLY NUMBERED. SIZES (EX. 2x4) OR OTHER INFO. FOLLOWING KEYNOTE ON DRAWINGS INDICATES CRITERIA FOR THOSE MATERIALS LOCATIONS WHICH MAY DIFFER FROM THE STD. MATERIAL SPECIFIED.

030000	-1	CONCRETE	092900	-1	GYPSUM BOARD (")
	-2	CONCRETE FLOOR SLAB	-2	FIRE RATED GYPSUM BOARD (")	
	-3	VAPOR BARRIER	-3	CEMENTITIOUS TILE BACKER PANEL	
	-4	WELDED WIRE FABRIC	-4	METAL SUSPENSION SYSTEM	
055000	-1	STEEL REINFORCING BAR	-5	ACOUSTICAL SEALANT	
	-2	STEEL ANGLE	-6	ACOUSTICAL INSULATION(")	
	-3	STEEL LINTEL	-7	METAL EDGE TRIM	
	-4	STEEL PLATE	-8	AUXILIARY SUPPORT FRAMING	
061000	-2	2X WOOD BLOCKING (")	-9	HIGH IMPACT GYPSUM BOARD	
	-3	PLY WOOD BACKER	-10	INTERIOR FINISHING COMPOUND	
064116	-1	PLASTIC LAMINATE-FACED ARCHITECTURAL CABINETS	-11	GLAZED WALL TILE ("X")	
	-2	GLAZED WALL TILE ("X")	-12	PORCELAIN FLOOR TILE ("X")	
	-3	CABINET LINER LAMINATE	-13	METAL EDGE STRIP	
	-4	PLYWOOD	-14	ACOUSTICAL PANEL (")	
	-5	3MM EDGE MOLDING	-15	CEILING SUSPENSION SYSTEM	
	-6	DOOR HINGE	095110	-1	EDGE HOLD TRIM
	-7	DOOR/DRAWER PULL	-2	AUXILIARY SUPPORT FRAMING	
	-8	MAGNETIC CATCH	-3	RESILIENT WALL BASE	
	-9	DRAWER	-4	EDGE STRIP	
	-10	SHELF SUPPORTS	096513	-1	RESILIENT SHEET FLOORING
	-11	COUNTERTOP SUPPORT BRACKET	096516	-1	RESILIENT FLOOR TILE
072100	-4	BUILDING INSULATION-FACED (R.)	096519	-1	CARPET TILE
	-5	SILL SEALER	097200	-1	WALL COVERING
	-6	SAFING INSULATION	099123	-1	INTERIOR PAINT
076200	-1	SHEET METAL FLASHING AND COUNTERFLASHING	101100	-1	MARKERBOARD
	-2	JOINT SEALANT - RAKE	101400	-1	DIMENSIONAL LETTER SIGNAGE
	-3	JOINT FILLER	102113.17	-1	PHENOLIC CORE TOILET COMPARTMENT
	-4	GASKET	102600	-1	CORNER GUARD
	-5	BACKER ROD	-2	FRR IMPACT RESISTANT WALLCOVERING	
081113	-2	HOLLOW METAL FRAME	102800	-1	SOAP DISPENSER
	-3	FRAME ANCHOR	-2	TOILET TISSUE DISPENSER	
081416	-1	FLUSH WOOD DOOR	-3	PAPER TOWEL DISPENSER	
083113	-1	ACCESS DOOR	-4	FRAMED MIRROR	
	-2	ACCESS DOOR FRAME	-5	SANITARY NAPKIN DISPOSER	
084113	-1	ALUMINUM ENTRANCE DOOR	-6	GRAB BAR	
	-2	ALUMINUM STOREFRONT FRAME	-7	DIAPER CHANGING STATION	
	-3	GLAZING (AS SCHEDULED)	104413	-1	FIRE EXTINGUISHER CABINET
088000	-1	STEEL STUD (")	124113	-1	ROLLER WINDOW SHADES
092216	-1	STEEL STUD RUNNER (")	123553.13	-1	METAL LABORATORY CASEWORK
	-2	FURRING CHANNEL	123661.16	-1	SOLID SURFACE COUNTERTOP
	-3		134900	-1	LEAD LINED GYP. BD
	-4		-2	LEAD GLASS	
	-5		-3	HOLLOW METAL FRAME	
	-6		-4	LEAD LINED WOOD DOOR	

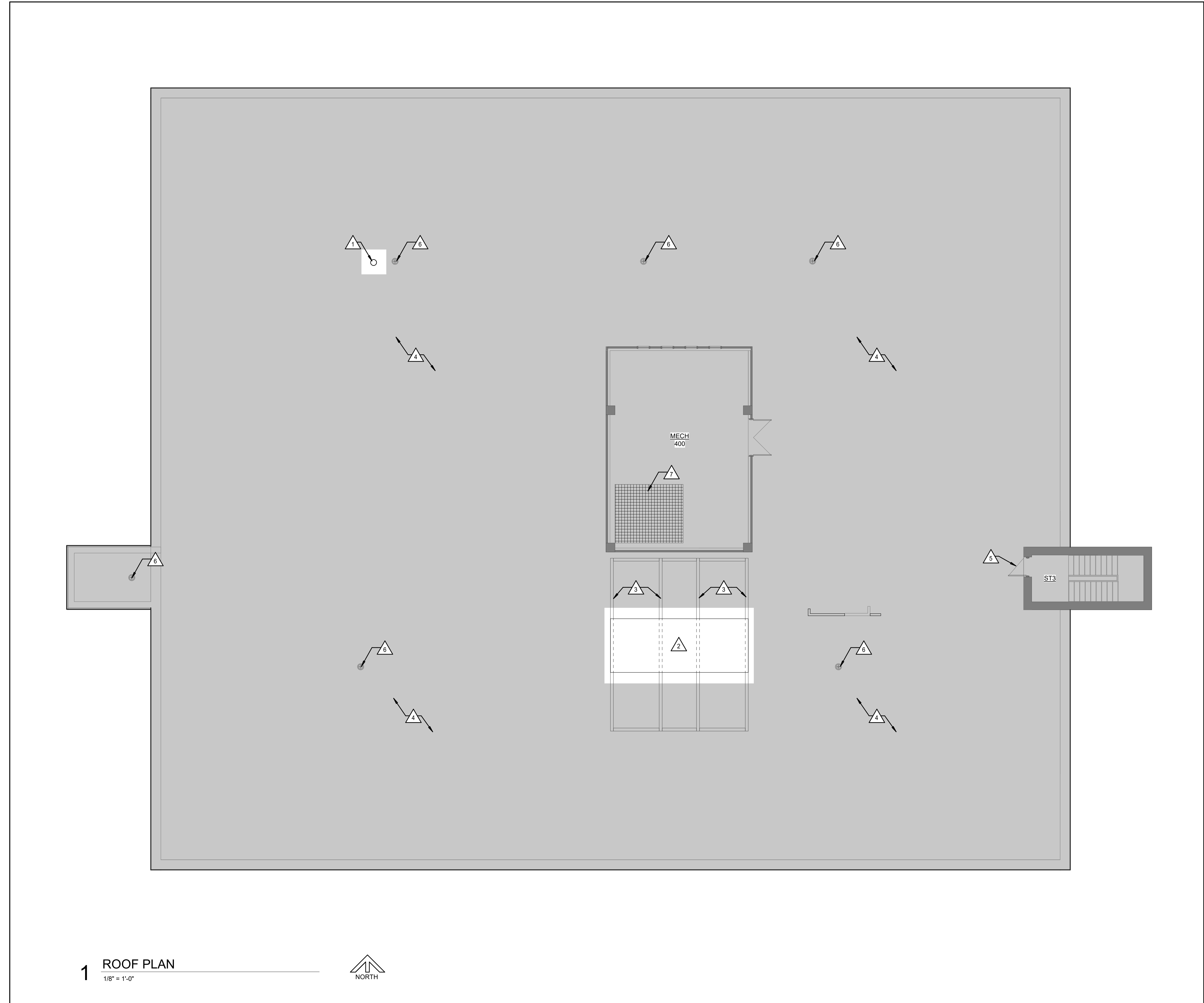

1 ROOF PLAN
 1/8" = 1'-0"
 NORTH

Autodesk Docs://2312.03 WU Mabee Library/2312.03 WU Mabee Library.rvt 7/16/2024 1:11:20 PM

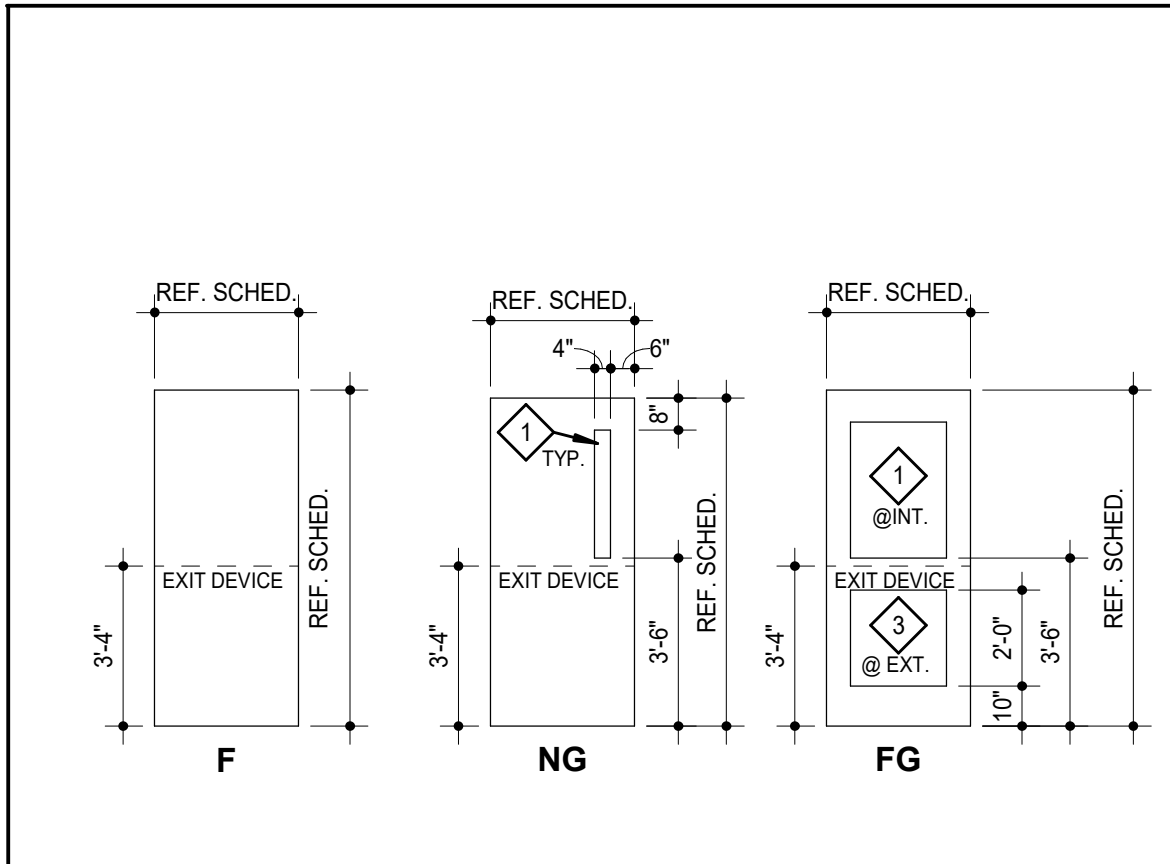

DOOR TYPES

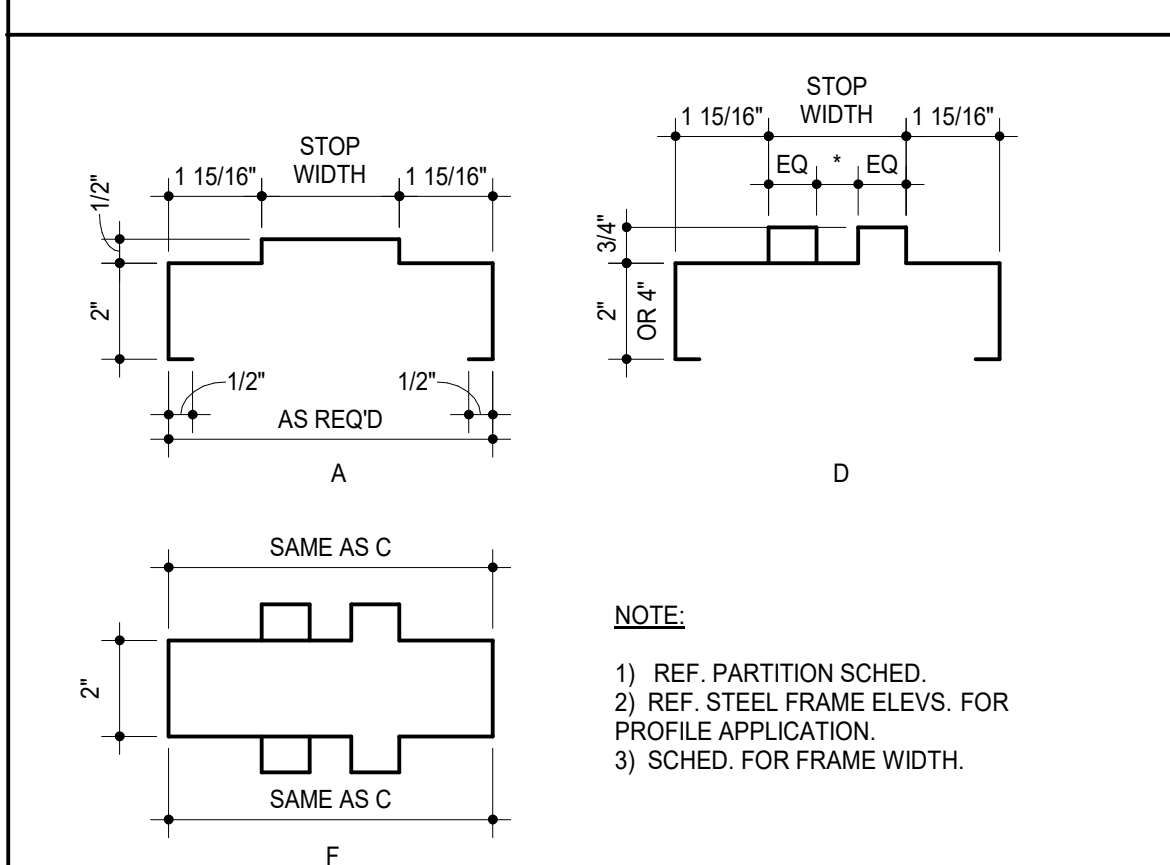

HOLLOW METAL FRAME PROFILES

GLASS SCHEDULE

MARK TYPE	DESCRIPTION
◇	1/4" Clear Tempered
◇	Glass equivalent to 1/16" lead lining
◇	1" Insulating
◇	A) Exterior 1/4" Tinted

DOOR & FRAME SCHEDULE NOTES

- Field verify conditions at all exist. openings & modify as req'd to fit.
- All aluminum frames are 4 1/2" deep and 2" wide - u.n.o.
- All steel welded frames are 3/4" wider than nominal wall width - u.n.o.
- All doors are 1 3/4" thick unless noted otherwise.
- Letters in parentheses () A, B, C, D, E, & F at top of various columns in the schedule are for column identification & are clarified as follows:
 - (A) To identify DOOR TYPES refer to DOOR TYPES this sheet.
 - (B) For DOOR MATERIAL AND FRAME MATERIAL:
 - A = Aluminum
 - W = Wood
 - (C) To identify FRAME TYPES refer to HOLLOW METAL FRAME ELEVATIONS & ALUMINUM FRAME ELEVATIONS.
 - (D) FRAME DETAILS are referenced and shown as follows, unless noted otherwise:
 - Frame Details are referenced in Door and Frame Schedule, and shown on this sheet.
 - Hollow Metal Frame Profiles are referenced on Hollow Metal Frame Elevations, and shown on this sheet.
 - Glass types are shown on Frame Elevations.
 - (E) SCHEDULE NOTES:
 - 1/32" Lead Lined Door
 - Provide Card Reader
 - New door & frame in existing wall, overcut opening as req'd for opening reinforcement
 - New hardware in existing door
 - Prep for future card reader.

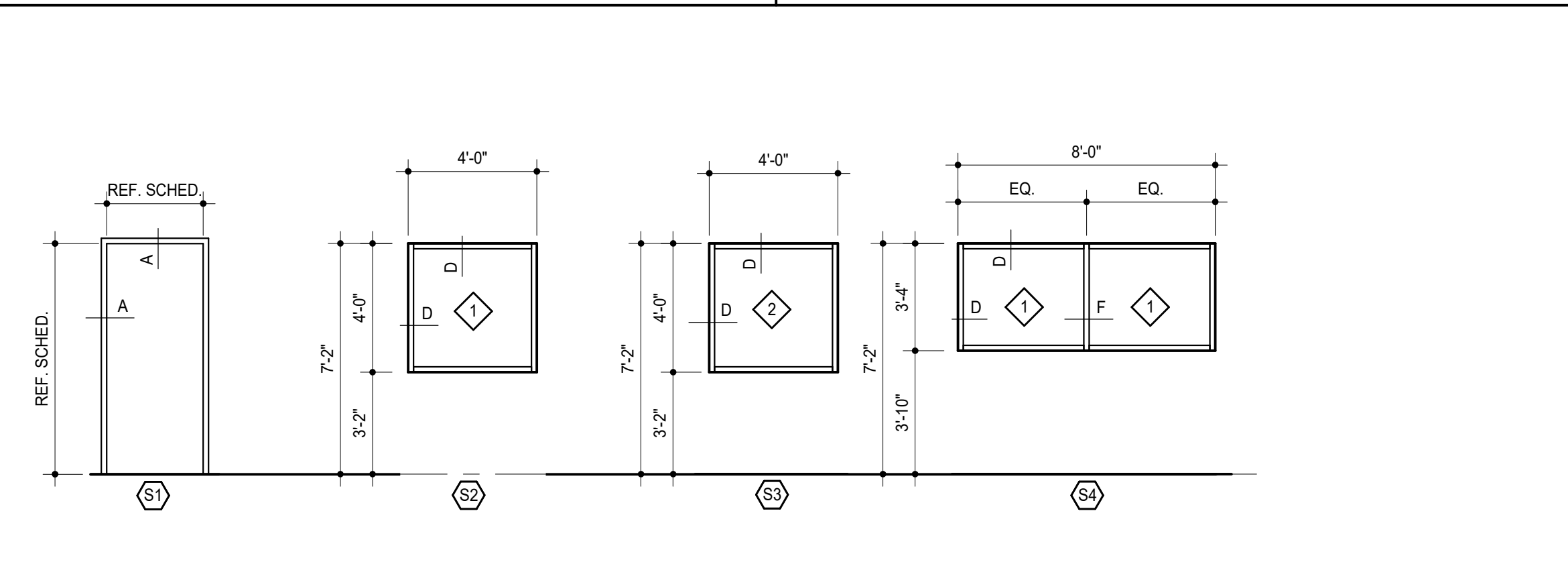

HOLLOW METAL FRAMES

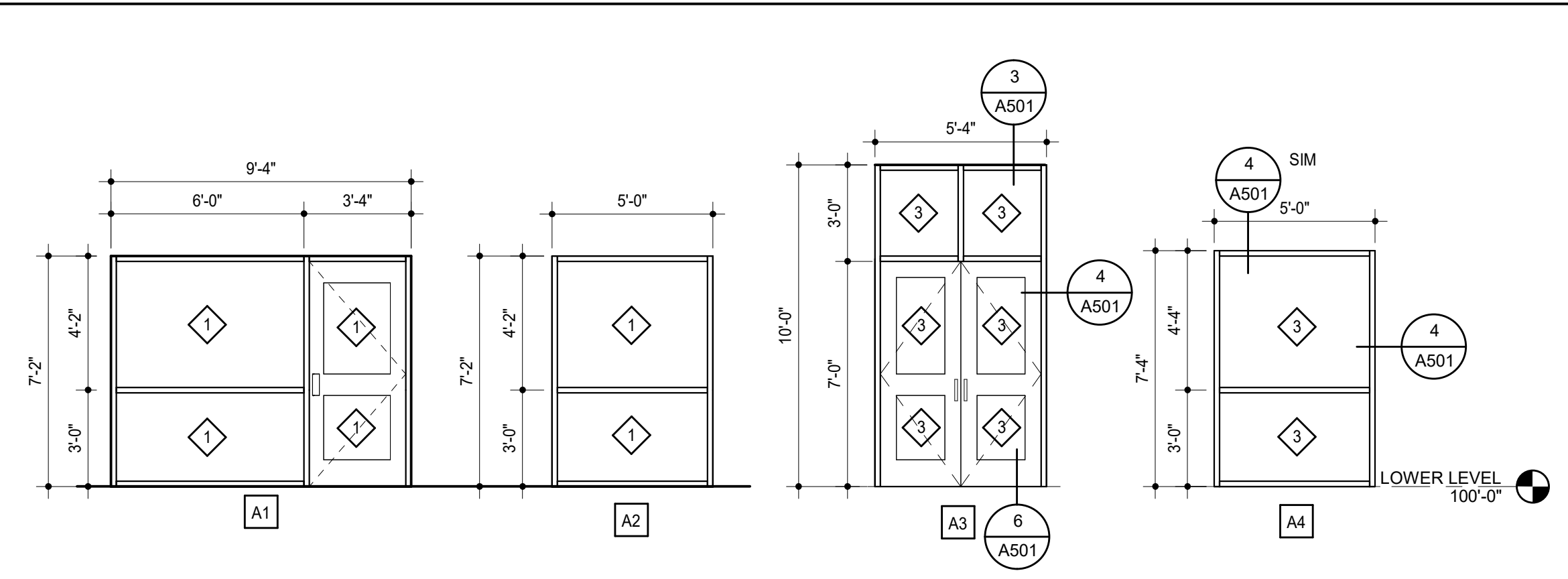

ALUMINUM FRAMES

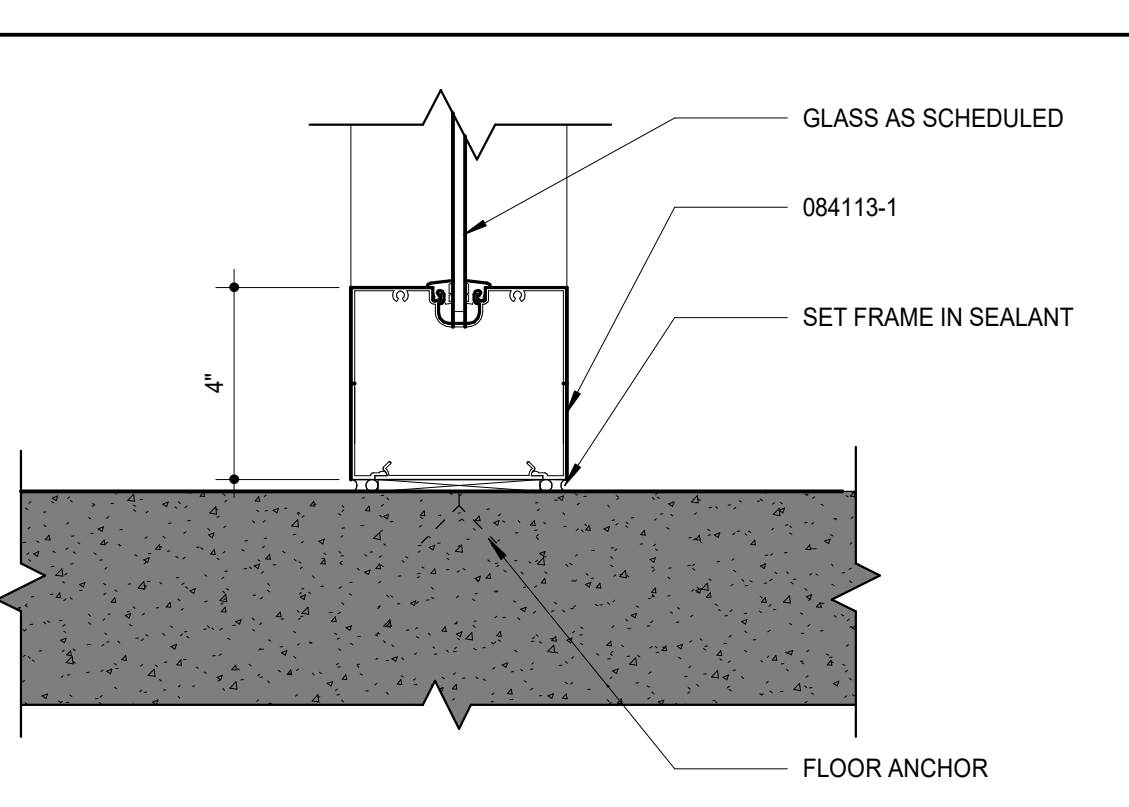

1 ALUMINUM SIDELIGHT SILL DETAIL
3" x 1'-0"

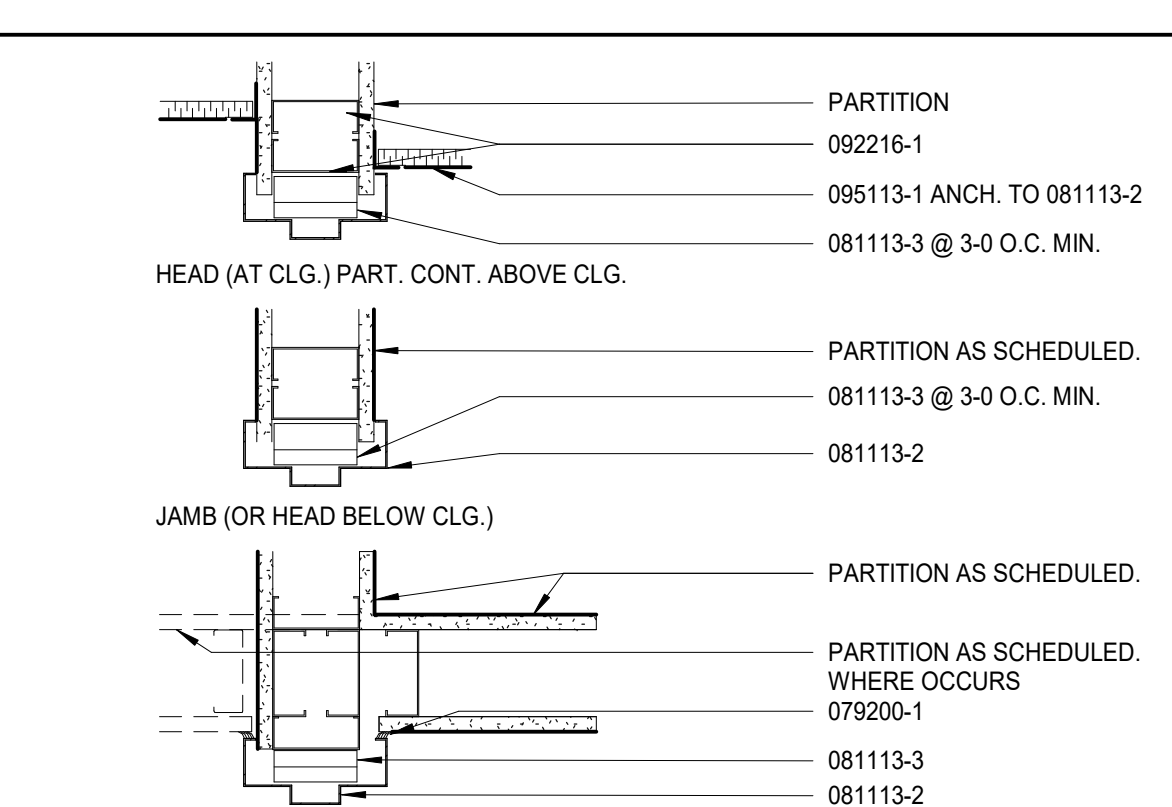

2 GYP. BD. PARTITION HEAD & JAMB DTL
1 1/2" x 1'-0"

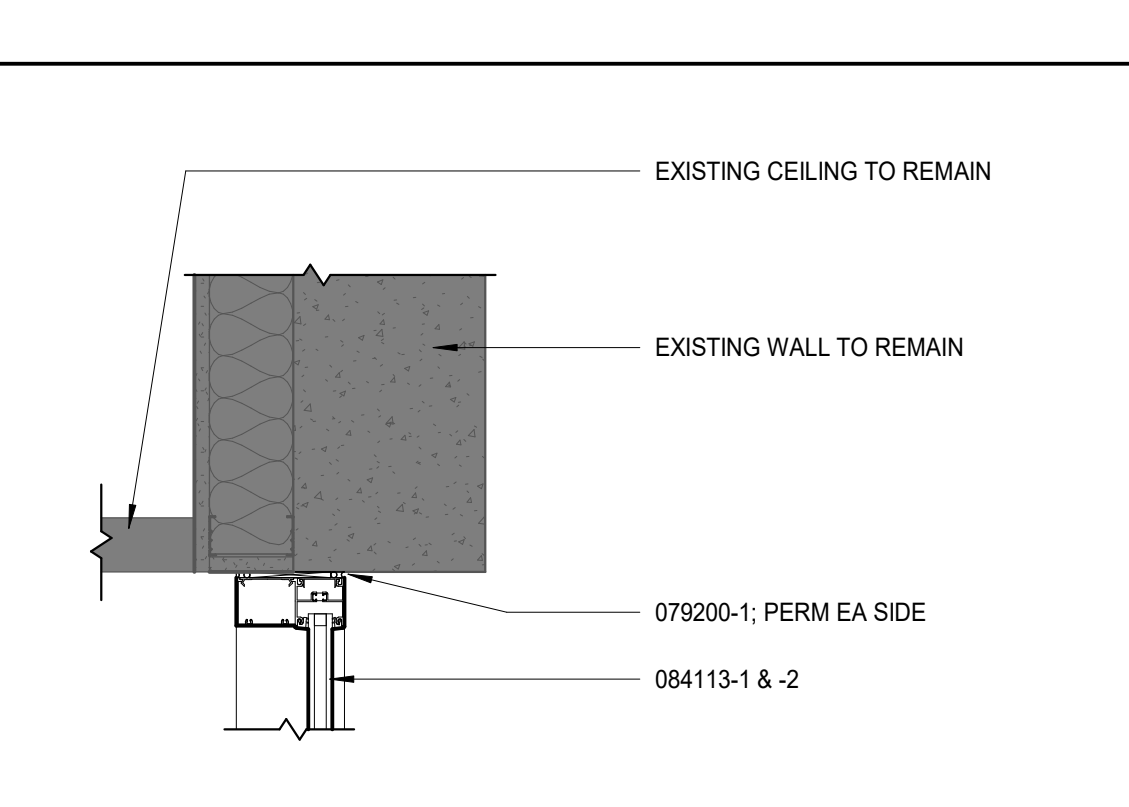

3 ALUM HEAD @ EXT. WALL
1 1/2" x 1'-0"

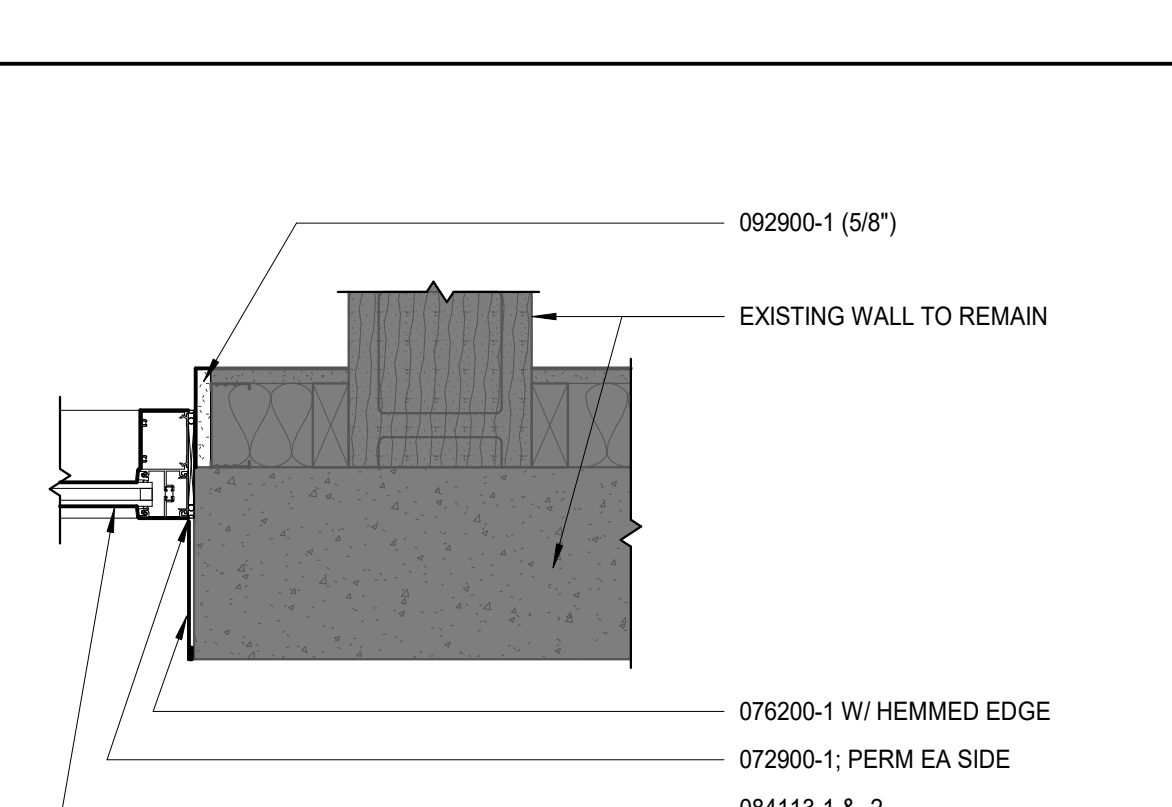

4 ALUM JAMB @ EXIST WALL
1 1/2" x 1'-0"

DOOR AND FRAME SCHEDULE

MARK	DOOR		FRAME						RATING	NOTES (E)	
	W	H	TYPE (A)	MATERIAL (B)	MATERIAL (B)	TYPE (C)	HEAD (D)	JAMB (D)			OTHER (D)
100	5'-0"	7'-0"	FG	A	A	A3	3	4	6	5	
100R	3'-0"	7'-0"	EXIST	W	HM	EXIST	EXIST	EXIST		4	
101R	3'-0"	7'-0"	EXIST	W	HM	EXIST	EXIST	EXIST		4	
104	3'-0"	7'-0"	F	W	HM	S1	2	2		45	4
107	3'-0"	7'-0"	NG	W	HM	S1	2	2			
108A	3'-0"	7'-0"	F	W	HM	S1	2	2			
108B	3'-0"	7'-0"	F	W	HM	S1	2	2			
109	4'-0"	7'-0"	NG	W	HM	S1	2	2			
110A	4'-0"	7'-0"	NG	W	HM	S1	2	2			
110B	4'-0"	7'-0"	NG	W	HM	S1	2	2			
110C	4'-0"	7'-0"	NG	W	HM	S1	2	2			
111	3'-0"	7'-0"	NG	W	HM	S1	2	2			
112	4'-0"	7'-0"	NG	W	HM	S1	2	2			
112A	4'-0"	7'-0"	F	W	HM	S1	2	2			
116	4'-0"	7'-0"	F	W	HM	S1	2	2			1
117A	3'-0"	7'-0"	F	W	HM	S1	2	2			1
117B	3'-0"	7'-0"	NG	W	HM	S1	2	2			
118A	4'-0"	7'-0"	F	W	HM	S1	2	2			1
118B	3'-0"	7'-0"	F	W	HM	S1	2	2			1
119	3'-0"	7'-0"	NG	W	HM	S1	2	2			2
200RR	3'-0"	7'-0"	F	W	HM	S1	2	2			
201A	3'-0"	7'-0"	NG	W	HM	S1	2	2			
201B	3'-0"	7'-0"	F	W	HM	S1	2	2			
201C	3'-0"	7'-0"	NG	W	HM	S1	2	2			
201D	3'-0"	7'-0"	NG	W	HM	S1	2	2			
201E	3'-0"	7'-0"	NG	W	HM	S1	2	2			
201F	3'-0"	7'-0"	NG	W	HM	S1	2	2			
201G	3'-0"	7'-0"	NG	W	HM	S1	2	2			
201H	3'-0"	7'-0"	NG	W	HM	S1	2	2			
201H3	3'-0"	7'-0"	NG	W	HM	S1	2	2			3
201I	3'-0"	7'-0"	NG	W	HM	S1	2	2			
201J	3'-0"	7'-0"	NG	W	HM	S1	2	2			
201K	3'-0"	7'-0"	NG	W	HM	S1	2	2			
201L	3'-0"	7'-0"	NG	W	HM	S1	2	2			
201M	3'-0"	7'-0"	NG	W	HM	S1	2	2			
201N	3'-0"	7'-0"	NG	W	HM	S1	2	2			
201O	3'-0"	7'-0"	NG	W	HM	S1	2	2			
201P	3'-0"	7'-0"	NG	W	HM	S1	2	2			
201Q	3'-0"	7'-0"	NG	W	HM	S1	2	2			
201RR	3'-0"	7'-0"	F	W	HM	S1	2	2			
201T	3'-0"	7'-0"	NG	W	HM	S1	2	2			
201U	3'-0"	7'-0"	NG	W	HM	S1	2	2			
201V	3'-0"	7'-0"	NG	W	HM	S1	2	2			
201W	3'-0"	7'-0"	NG	W	HM	S1	2	2			
201X	3'-0"	7'-0"	NG	W	HM	S1	2	2			
201Y	3'-0"	7'-0"	NG	W	HM	S1	2	2			
207	3'-0"	7'-0"	NG	W	HM	S1	2	2			
208	3'-0"	7'-0"	NG	W	HM	S1	2	2			
209	3'-0"	7'-0"	F	W	HM	S1	2	2			
210	3'-0"	7'-0"	NG	W	HM	S1	2	2			
210A	3'-0"	7'-0"	FG	A	A	A1	5	5	1		
210B	3'-0"	7'-0"	NG	W	HM	S1	2	2			
210C	3'-0"	7'-0"	NG	W	HM	S1	2	2			
210D	3'-0"	7'-0"	NG	W	HM	S1	2	2			
210E	3'-0"	7'-0"	NG	W	HM	S1	2	2			
210F	3'-0"	7'-0"	F	W	HM	S1	2	2			
210G	3'-0"	7'-0"	NG	W	HM	S1	2	2			
210H	3'-0"	7'-0"	NG	W	HM	S1	2	2			
300A	3'-0"	7'-0"	EXIST	ALUM	A	EXIST	EXIST	EXIST			4
300B	3'-0"	7'-0"	EXIST	ALUM	A	EXIST	EXIST	EXIST			4
301	3'-0"	7'-0"	FG	A	A	A1	5	5	1		
301A	3'-0"	7'-0"	NG	W	HM	S1	2	2			
301B	3'-0"	7'-0"	NG	W	HM	S1	2	2			
301C	3'-0"	7'-0"	NG	W	HM	S1	2	2			
301D	3'-0"	7'-0"	NG	W	HM	S1	2	2			
301E	3'-0"	7'-0"	NG	W	HM	S1	2	2			
301F	3'-0"	7'-0"	F	W	HM	S1	2	2			
301G	3'-0"	7'-0"	NG	W	HM	S1	2	2			
301H	3'-0"	7'-0"	NG	W	HM	S1	2	2			
301I	3'-0"	7'-0"	NG	W	HM	S1	2	2			
301J	3'-0"	7'-0"	NG	W	HM	S1	2	2			
301K	3'-0"	7'-0"	NG	W	HM	S1	2	2			
302	3'-0"	7'-0"	NG	W	HM	S1	2	2			
305	4'-0"	7'-0"	F	W	HM	S1	2	2			
306	3'-0"	7'-0"	NG	W	HM	S1	2	2			
306A	3'-0"	7'-0"	F	W	HM	S1	2	2			
307	3'-0"	7'-0"	FG	A	A	A1	5	5	1		
307B	3'-0"	7'-0"	NG	W	HM	S1	2	2			
307C	3'-0"	7'-0"	NG	W	HM	S1	2	2			
307D	3'-0"	7'-0"	NG	W	HM	S1	2	2			
308	3'-0"	7'-0"	NG	W	HM	S1	2	2			
309	3'-0"	7'-0"	FG	A	A	A1	5	5	1		
309A	3'-0"	7'-0"	NG	W	HM	S1	2	2			
309B	3'-0"	7'-0"	NG	W	HM	S1	2	2			
309C	3'-0"	7'-0"	NG	W	HM	S1	2	2			
309D	3'-0"	7'-0"	NG	W	HM	S1	2	2			
309E	3'-0"	7'-0"	NG	W	HM	S1	2	2			
309F	3'-0"	7'-0"	NG	W	HM	S1	2	2			
309G	3'-0"	7'-0"	NG	W	HM	S1	2	2			
309H	3'-0"	7'-0"	NG	W	HM	S1	2	2			
309J	3'-0"	7'-0"	NG	W	HM	S1	2	2			
309K	3'-0"	7'-0"	NG	W	HM	S1	2	2			
309L	3'-0"	7'-0"	NG	W	HM	S1	2	2			
309M	3'-0"	7'-0"	NG	W	HM	S1	2	2			
309N	3'-0"	7'-0"	F	W	HM	S1	2	2			
310	3'-0"	7'-0"	NG	W	HM	S1	2	2			
311	3'-0"	7'-0"	NG	W	HM	S1	2	2			
311A	3'-0"	7'-0"	F	W	HM	S1	2	2			
312	3'-0"	7'-0"	NG	W	HM	S1	2	2			
313	3'-0"	7'-0"	NG	W	HM	S1	2	2			

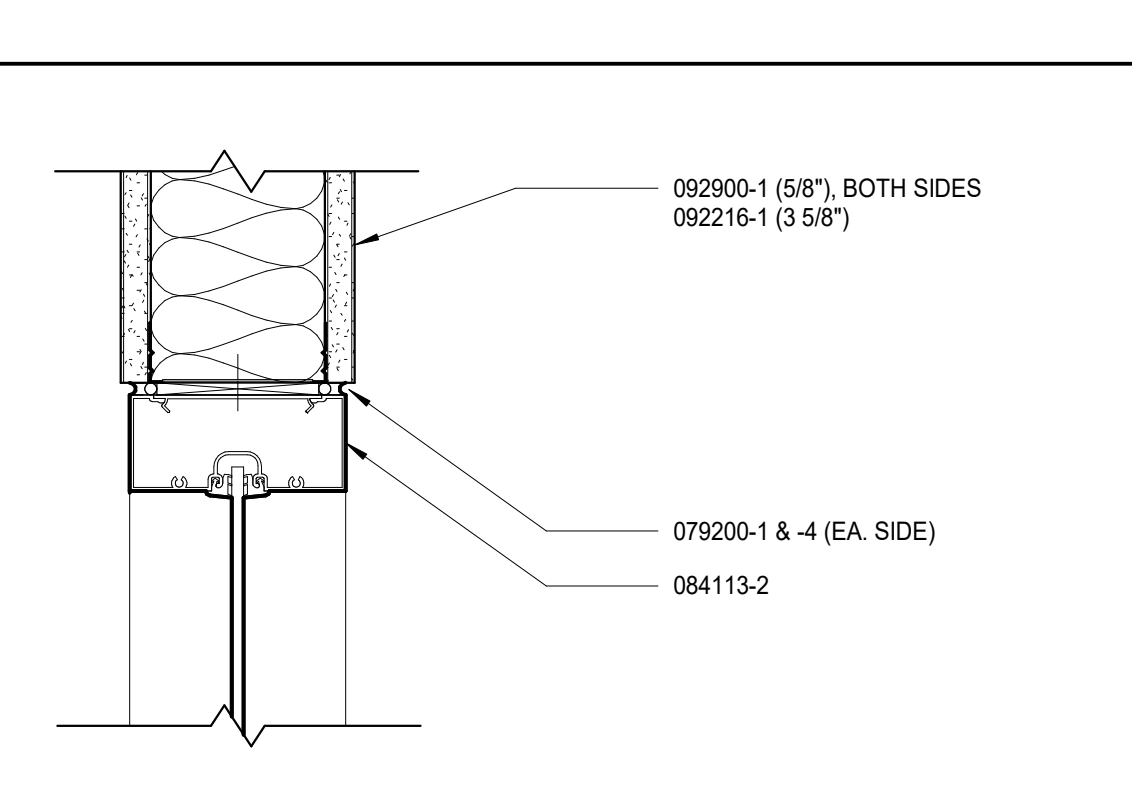

5 ALUM. STOREFRONT INT. FRAME
3" x 1'-0"

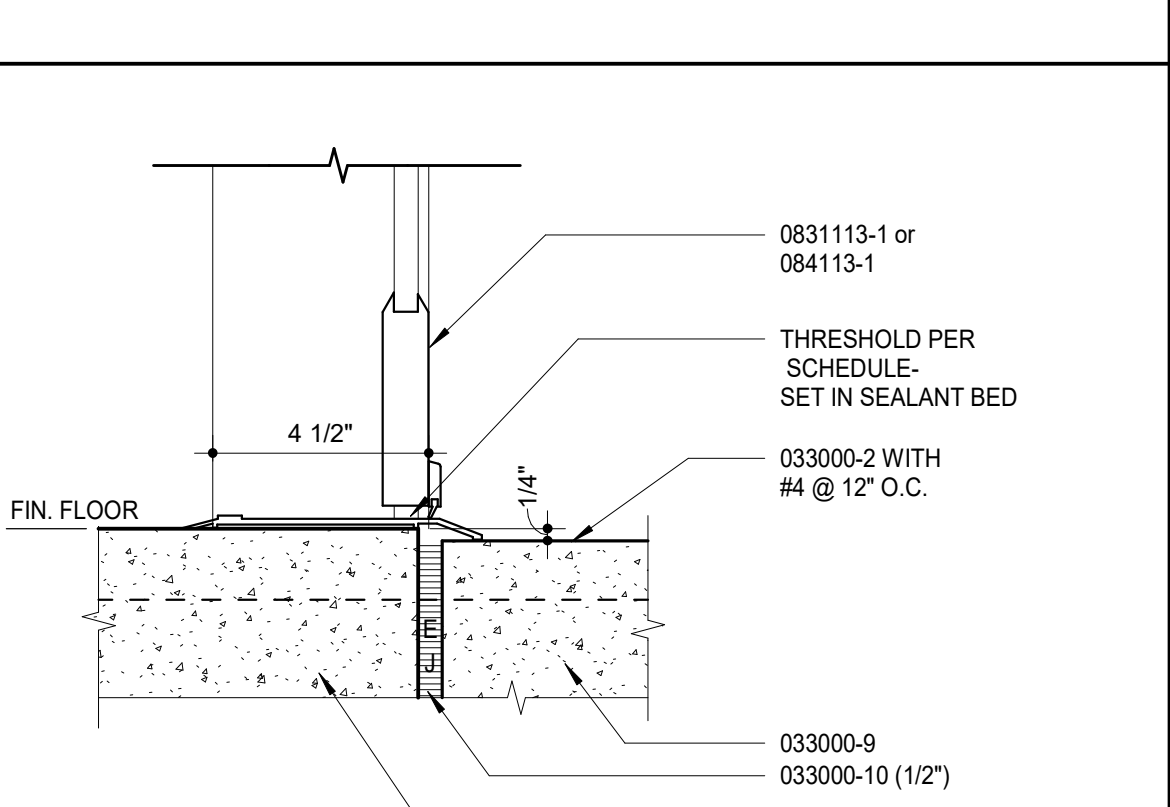

6 THRESHOLD @ AL. STOREFRONT DOOR
3" x 1'-0"

KEYNOTES

NOTE: KEYNOTES ARE DRAWN FROM A MASTER LIST AND MAY NOT BE SEQUENTIALLY NUMBERED. SIZES (E), 241 OR OTHER INFO FOLLOWING KEYNOTES ON DRAWINGS INDICATES CRITERIA FOR THOSE MATERIALS/LOCATIONS WHICH MAY DIFFER FROM THE STD. MATERIAL SPECIFIED.

KEYNOTE	DESCRIPTION
033000 -1	CONCRETE
033000 -2	CONCRETE FLOOR SLAB
033000 -3	VAPOR BARRIER
055000 -1	STEEL ANGLE
055000 -2	STEEL ANGLE
055000 -3	STEEL ANGLE
055000 -4	STEEL ANGLE
055000 -5	STEEL ANGLE
061100 -1	2X WOOD BLOCKING (*)
061100 -2	2X WOOD BLOCKING (*)
061100 -3	2X WOOD BLOCKING (*)</

7/16/2024 1:11:21 PM Autodesk Docs://2312.03 WU Mabee Library/2312.03 WU Mabee Library.rvt

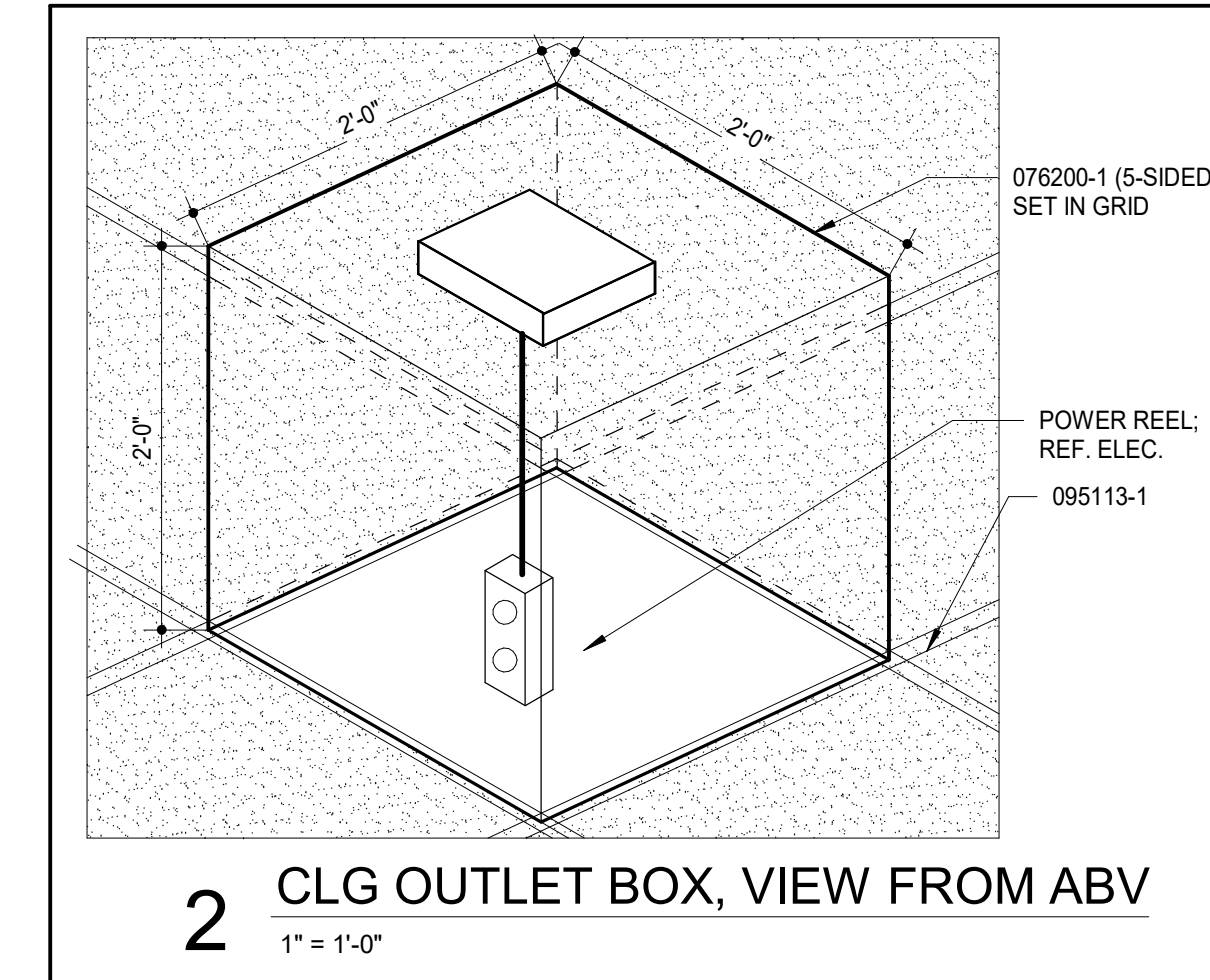

REFLECTED CEILING PLAN LEGEND

TYPICAL CEILING TAG	CEILING TYPE	HEIGHT OF CEILING ABOVE FLOOR
[Symbol]	TYPE A: CEILING TILE & GRID 2'-0" X 2'-0" ACOUSTICAL	
[Symbol]	TYPE B: CEILING TILE & GRID 2'-0" X 4'-0" ACOUSTICAL	
[Symbol]	TYPE G: PAINTED GYP. BD. & MTL. STUD SOFFIT	
[Symbol]	2'-0" X 2'-0" LIGHT FIXTURE, REF. ELEC.	
[Symbol]	2'-0" X 4'-0" LIGHT FIXTURE, REF. ELEC.	
[Symbol]	STRIP LIGHT FIXTURE, REF. ELEC.	
[Symbol]	DOWNLIGHT FIXTURE, REF. ELEC.	
[Symbol]	CEILING REGISTER, REF. MECH.	
[Symbol]	CEILING RETURN, REF. MECH.	
[Symbol]	POWER REEL, REF. ELEC. & 2/A600	

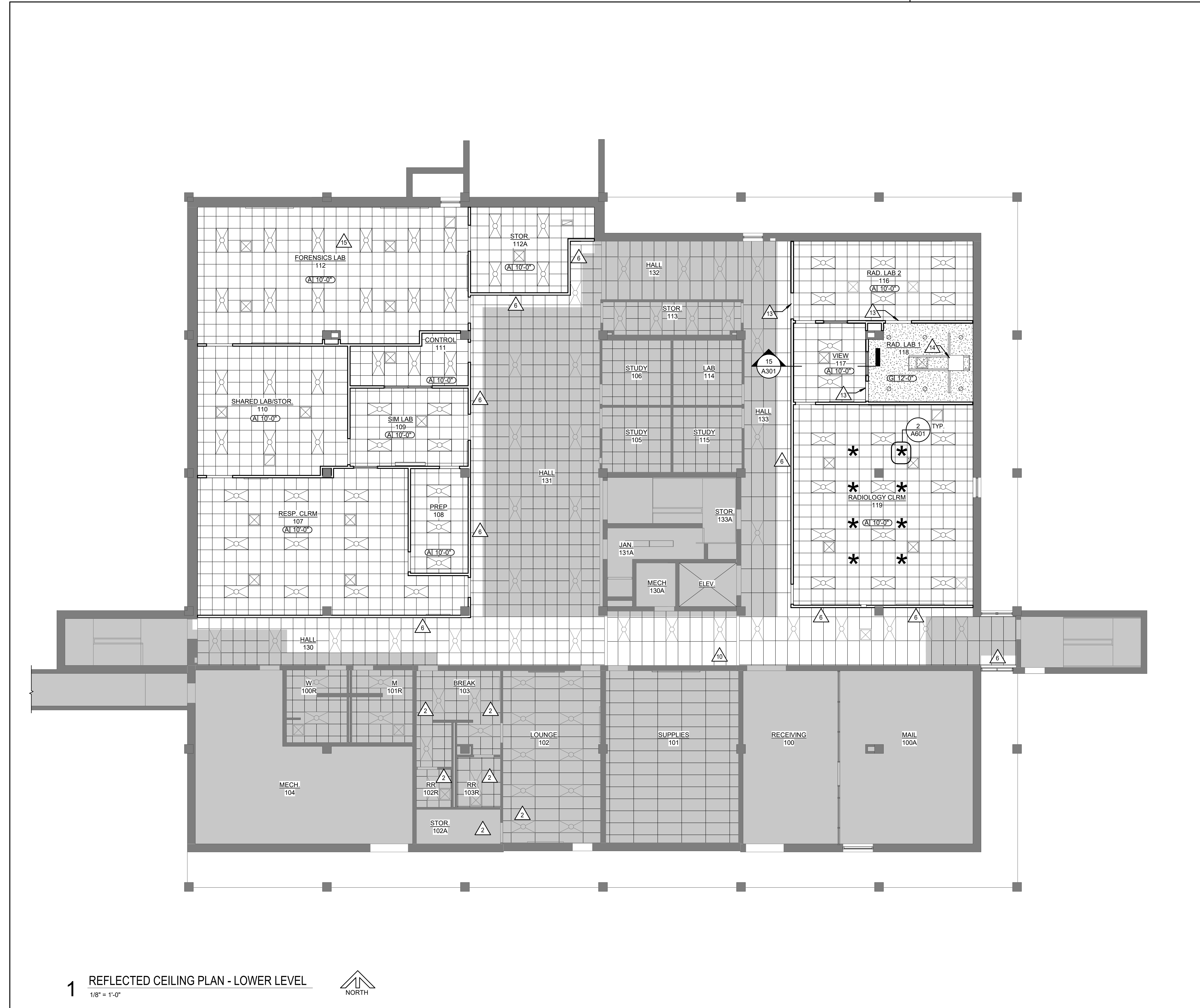

1 REFLECTED CEILING PLAN - LOWER LEVEL
1/8" = 1'-0"

NORTH

REFLECTED CEILING PLAN NOTES

GENERAL: COORDINATE WITH WORK SHOWN ON MECHANICAL, PLUMBING, AND ELECTRICAL DRAWINGS

1. REINSTALL EXISTING LIGHT FIXTURE IN NEW CEILING SYSTEM OTHER THAN AS REQ'D FOR SPRINKLER & OTHER MEP WORK SHOWN
2. EXISTING CEILING TO REMAIN; PATCH AS REQ'D
3. REPLACE LIGHTING; REF. ELEC.
4. PAINT EXISTING SOFFIT FACE & VERTICAL WALLS OF SOFFIT, EA SIDE OF WALL
5. SECURITY CAMERA; REF. MEP. REMOVE & RESET TILE AS NEEDED TO INSTALL CONDUIT & CABLING
6. PATCH CEILING GRID & TILE TO NEW WALL
7. FABRIC-WRAPPED PANELS SUSPENDED FROM CEILING
8. PROVIDE CEILING GRID & RE-INSTALL EXISTING CEILING TILE
9. ALIGN GRID WITH WALL
10. REMOVE AND REINSTALL GRID AS REQ'D FOR INSTALLATION OF NEW DUCTWORK
11. NOT USED
12. WRAP EXISTING HEADER IN G1a WALL TYPE
13. "X-RAY IN USE" SIGN, REF. MEP
14. EQUIPMENT; OWNER FURNISHED & INSTALLED
15. DOCUMENT CAMERA PROVIDED BY OWNER



DATE:
● July 16, 2024

REVISED DATE:
●
●
●

MABEE LIBRARY RENOVATION

Washburn University
1800 SW 19th Street, Topeka, KS 66621

SHEET CONTENTS:
● REFLECTED CEILING PLAN - LOWER LEVEL

HTK PROJECT NUMBER:
● 2312.03

SHEET NUMBER:
A601
ORIGINAL CONTRACT DOCUMENTS



DATE:
 ● July 16, 2024

REVISED DATE:

MABEE LIBRARY RENOVATION

Washburn University
 1800 SW 19th Street, Topeka, KS 66621

SHEET CONTENTS:
 ● REFLECTED CEILING PLAN - MAIN LEVEL

HTK PROJECT NUMBER:
 ● 2312.03

SHEET NUMBER:
A602

ORIGINAL CONTRACT DOCUMENTS

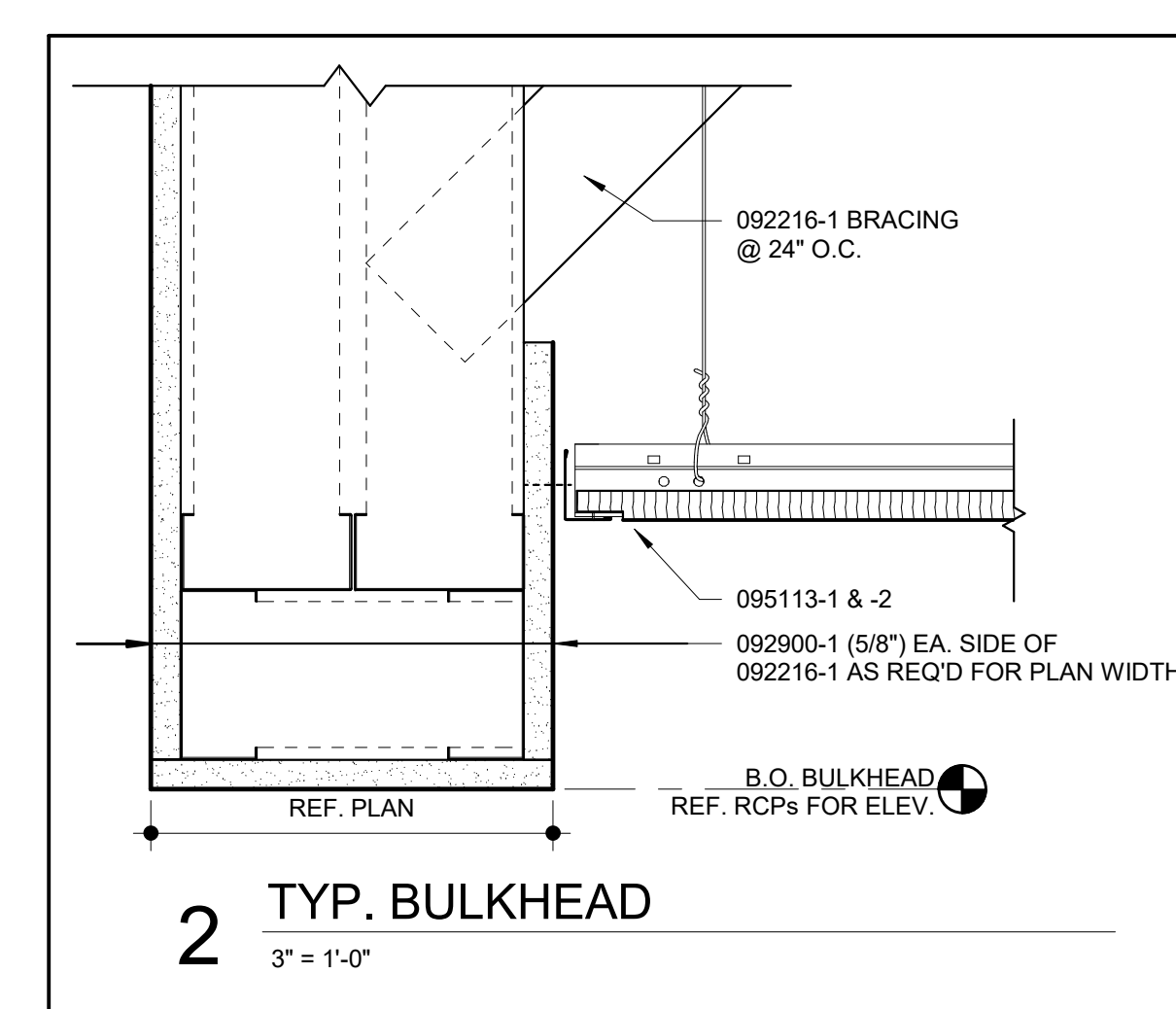

REFLECTED CEILING PLAN LEGEND

TYPICAL CEILING TAG	CEILING TYPE	HEIGHT OF CEILING ABOVE FLOOR
[Symbol]	TYPE A: CEILING TILE & GRID 2'-0" X 2'-0" ACOUSTICAL	
[Symbol]	TYPE A: CEILING TILE & GRID 2'-0" X 4'-0" ACOUSTICAL	
[Symbol]	TYPE G: PAINTED GYP. BD. & MTL. STUD SOFFIT	
[Symbol]	2'-0" X 2'-0" LIGHT FIXTURE, REF. ELEC.	
[Symbol]	2'-0" X 4'-0" LIGHT FIXTURE, REF. ELEC.	
[Symbol]	STRIP LIGHT FIXTURE, REF. ELEC.	
[Symbol]	DOWNLIGHT FIXTURE, REF. ELEC.	
[Symbol]	CEILING REGISTER, REF. MECH.	
[Symbol]	CEILING RETURN, REF. MECH.	
[Symbol]	POWER REEL, REF. ELEC. & 2/A600	

- REFLECTED CEILING PLAN NOTES**
- GENERAL: COORDINATE WITH WORK SHOWN ON MECHANICAL, PLUMBING, AND ELECTRICAL DRAWINGS
- 1 REINSTALL EXISTING LIGHT FIXTURE IN NEW CEILING SYSTEM OTHER THAN AS REQ'D FOR SPRINKLER & OTHER MEP WORK SHOWN
 - 2 EXISTING CEILING TO REMAIN; PATCH AS REQ'D
 - 3 REPLACE LIGHTING; REF. ELEC.
 - 4 PAINT EXISTING SOFFIT FACE & VERTICAL WALLS OF SOFFIT, EA SIDE OF WALL
 - 5 SECURITY CAMERA; REF. MEP. REMOVE & RESET TILE AS NEEDED TO INSTALL CONDUIT & CABLING
 - 6 PATCH CEILING GRID & TILE TO NEW WALL
 - 7 FABRIC-WRAPPED PANELS SUSPENDED FROM CEILING
 - 8 PROVIDE CEILING GRID & RE-INSTALL EXISTING CEILING TILE
 - 9 ALIGN GRID WITH WALL
 - 10 REMOVE AND REINSTALL GRID AS REQ'D FOR INSTALLATION OF NEW DUCTWORK
 - 11 NOT USED
 - 12 WRAP EXISTING HEADER IN G1a WALL TYPE
 - 13 "X-RAY IN USE" SIGN. REF. MEP
 - 14 EQUIPMENT; OWNER FURNISHED & INSTALLED
 - 15 DOCUMENT CAMERA PROVIDED BY OWNER



1 REFLECTED CEILING PLAN - MAIN LEVEL
 1/8" = 1'-0"

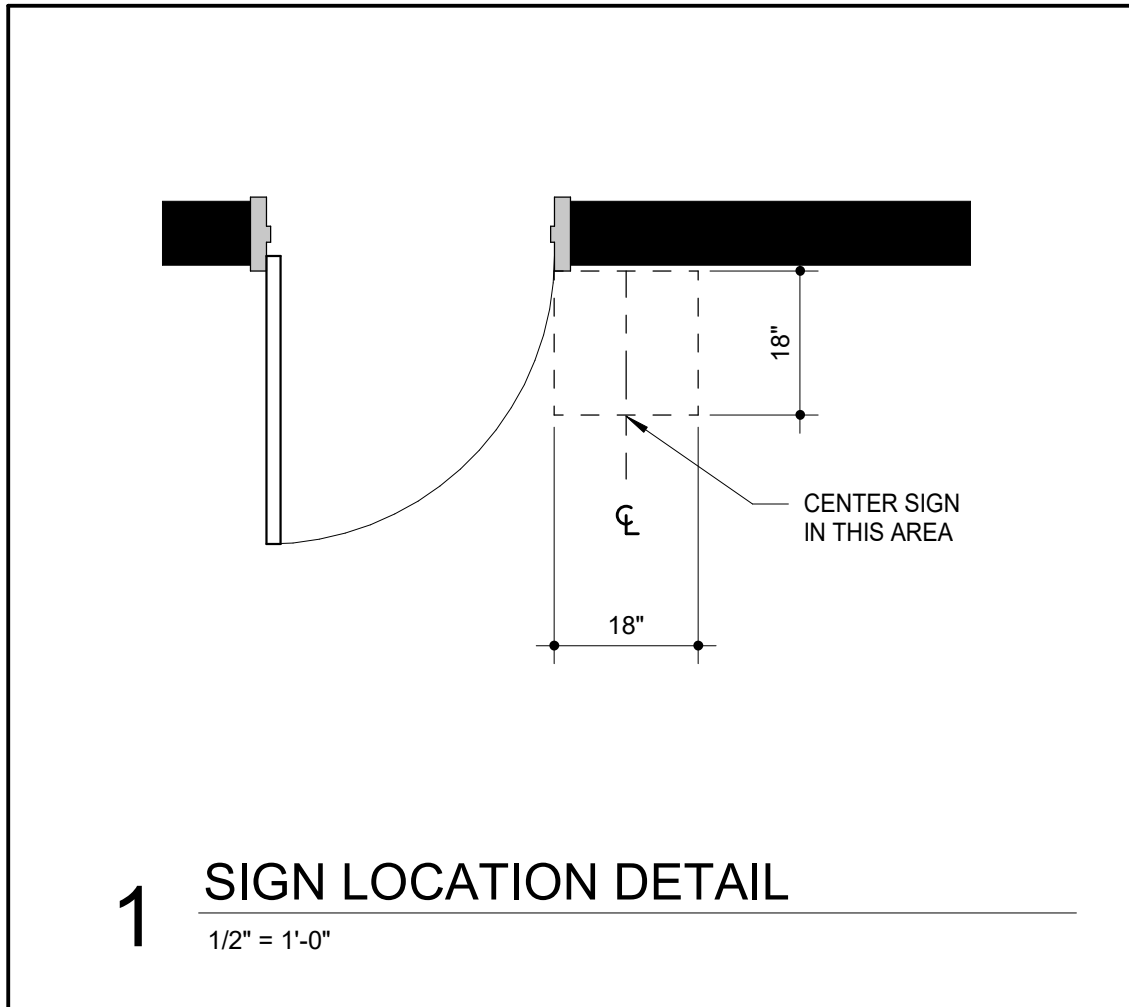

1 SIGN LOCATION DETAIL
1/2" = 1'-0"

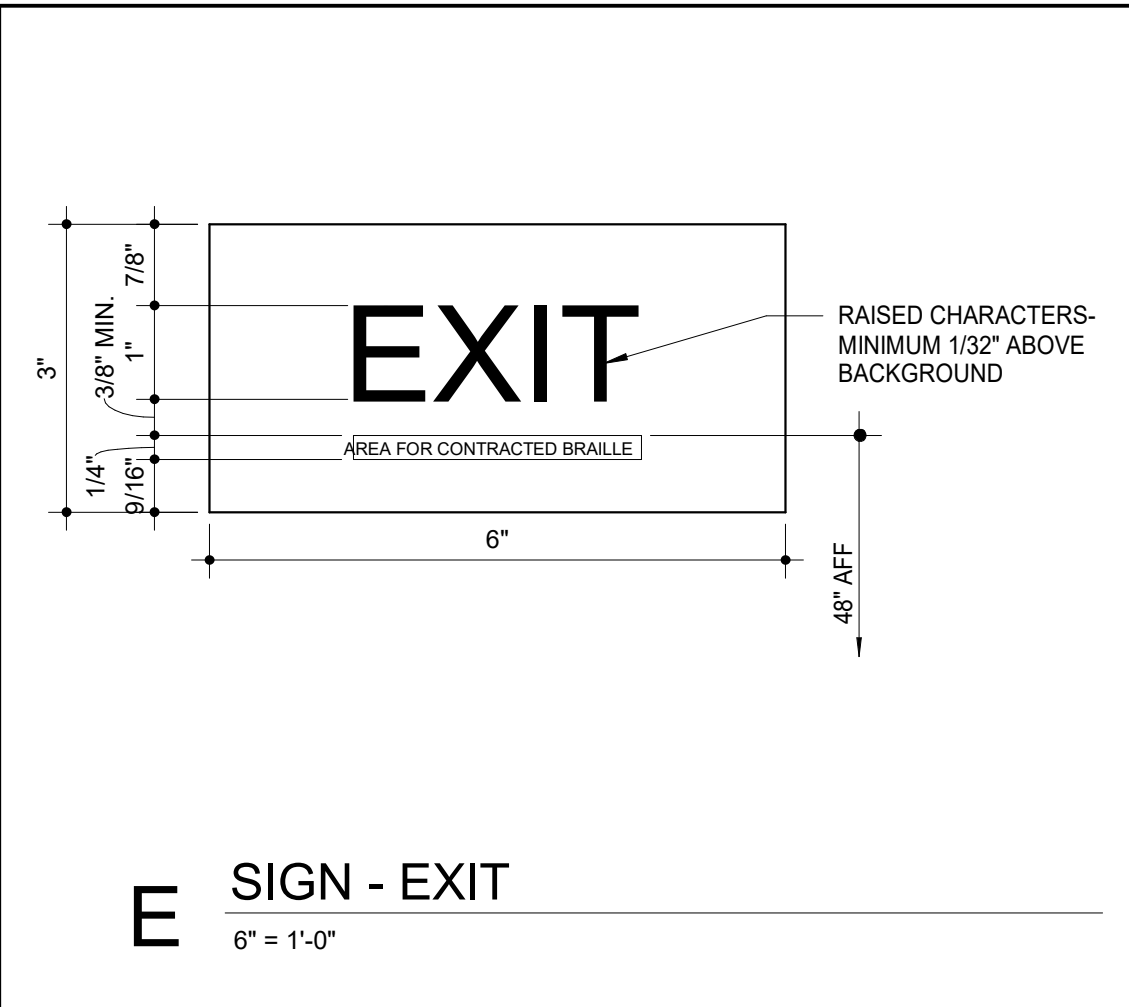

E SIGN - EXIT
6" = 1'-0"

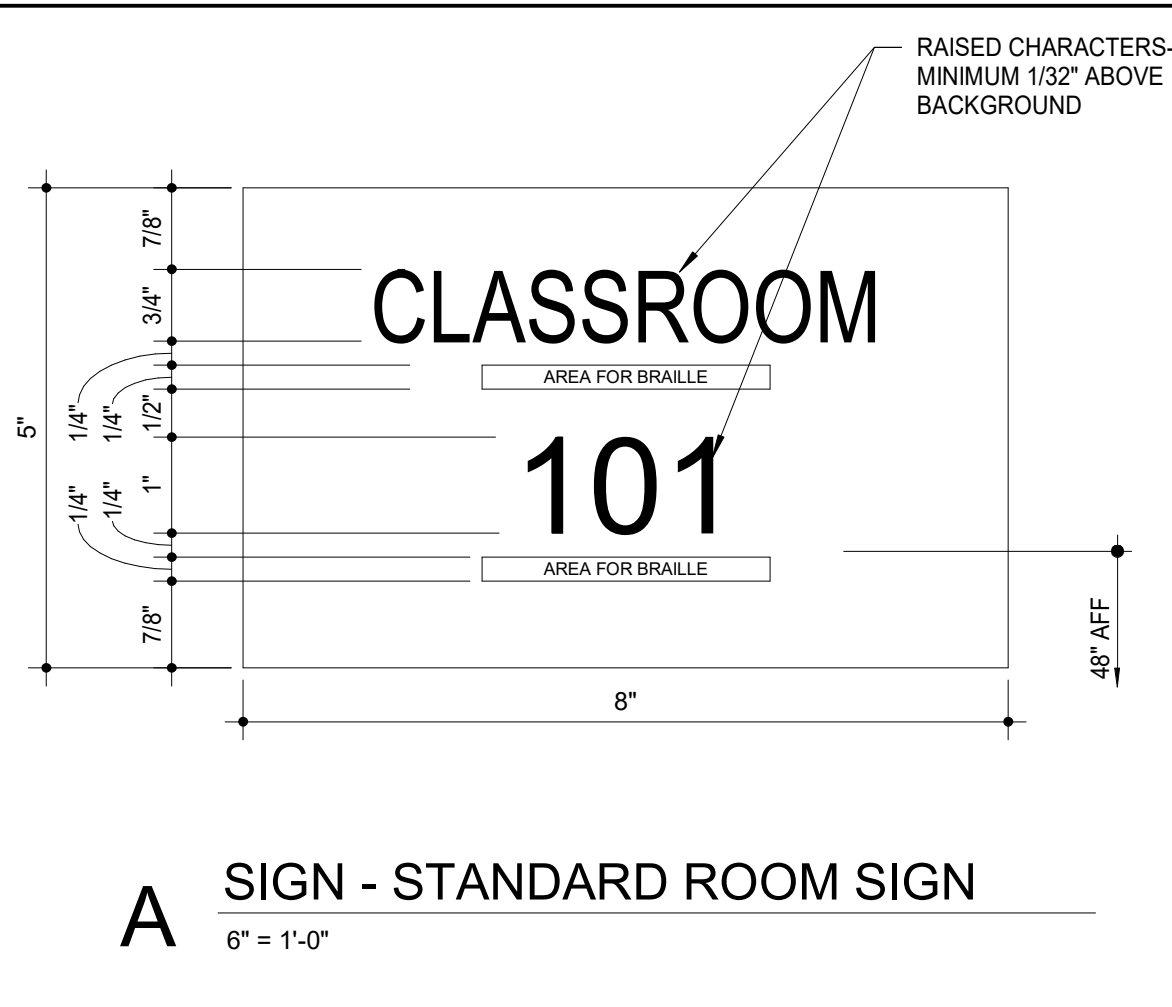

A SIGN - STANDARD ROOM SIGN
6" = 1'-0"

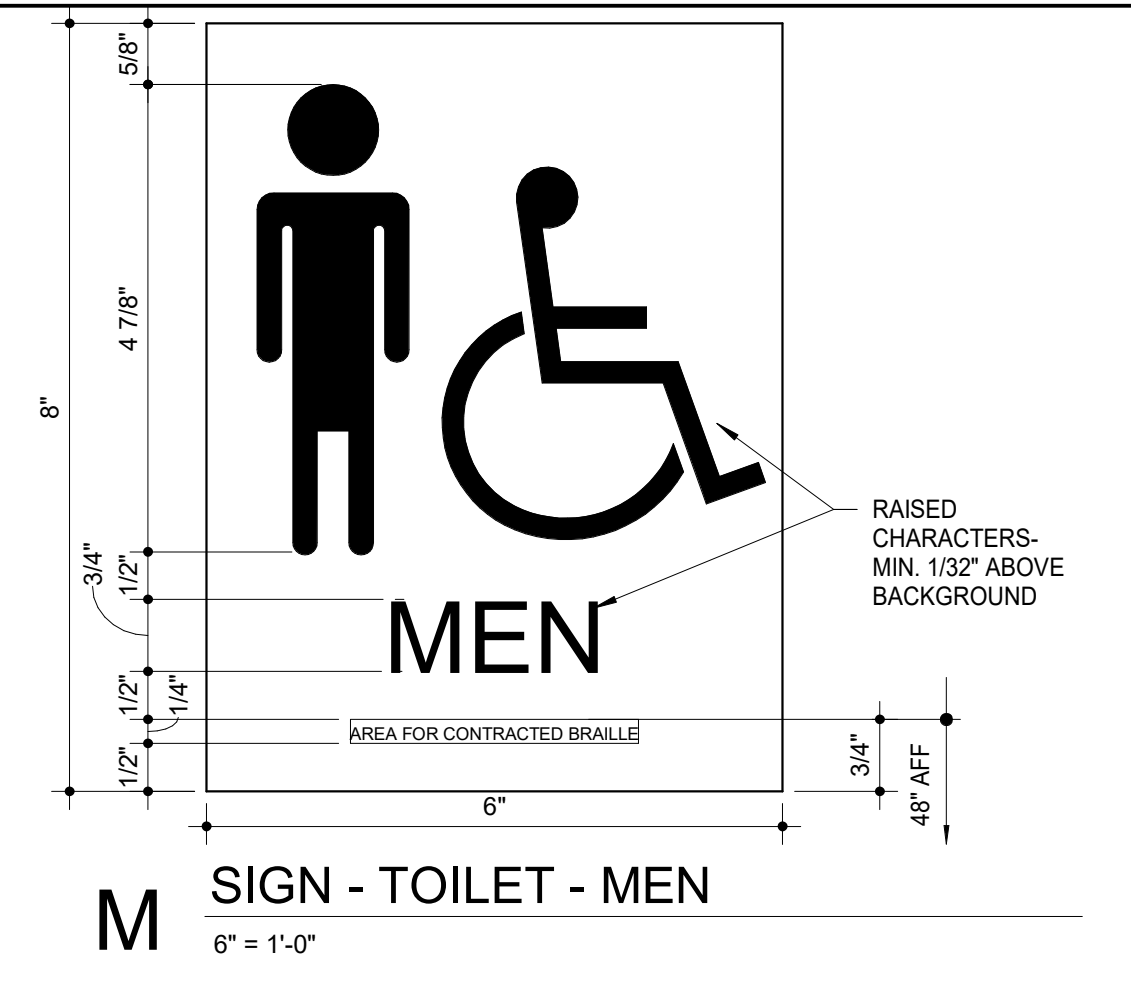

M SIGN - TOILET - MEN
6" = 1'-0"

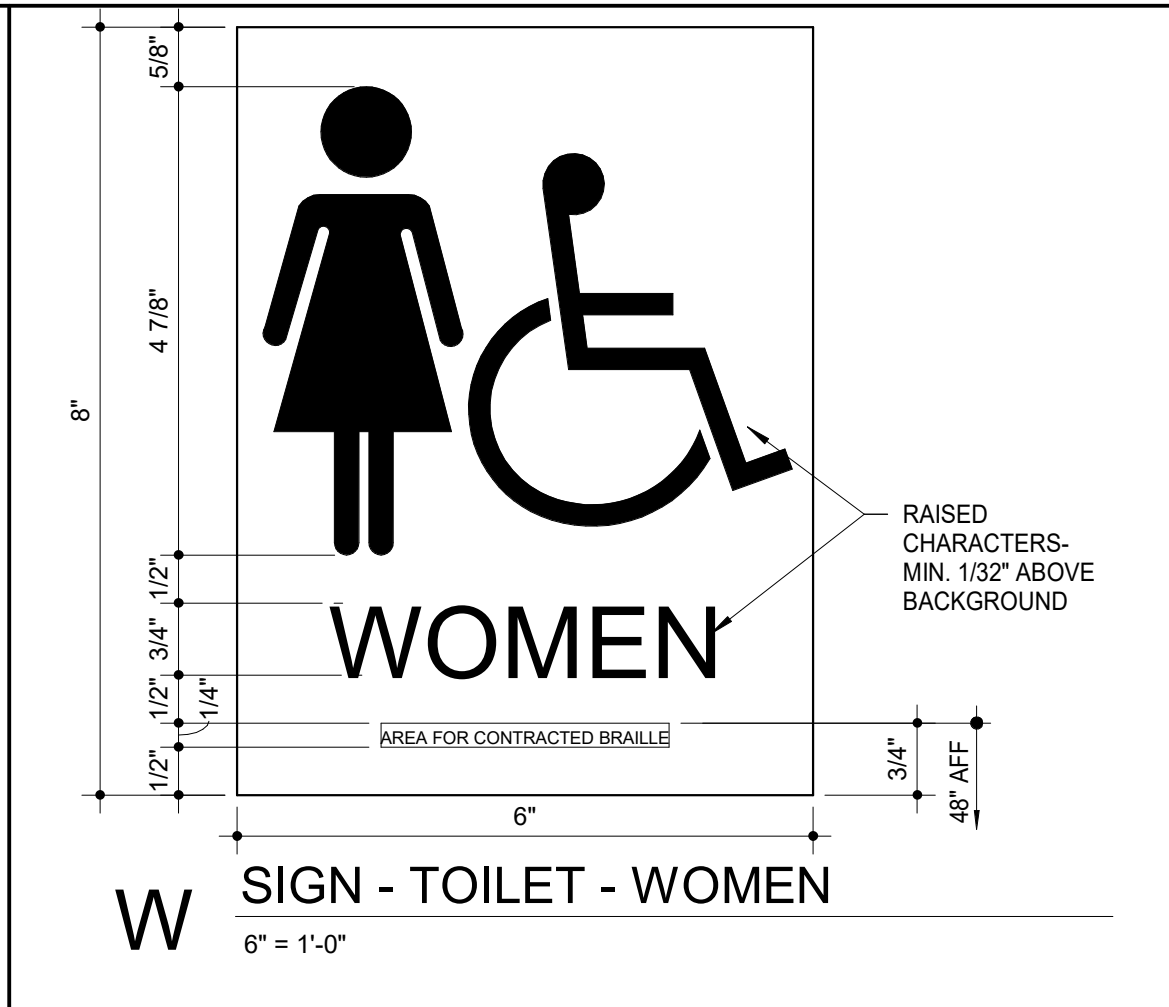

W SIGN - TOILET - WOMEN
6" = 1'-0"

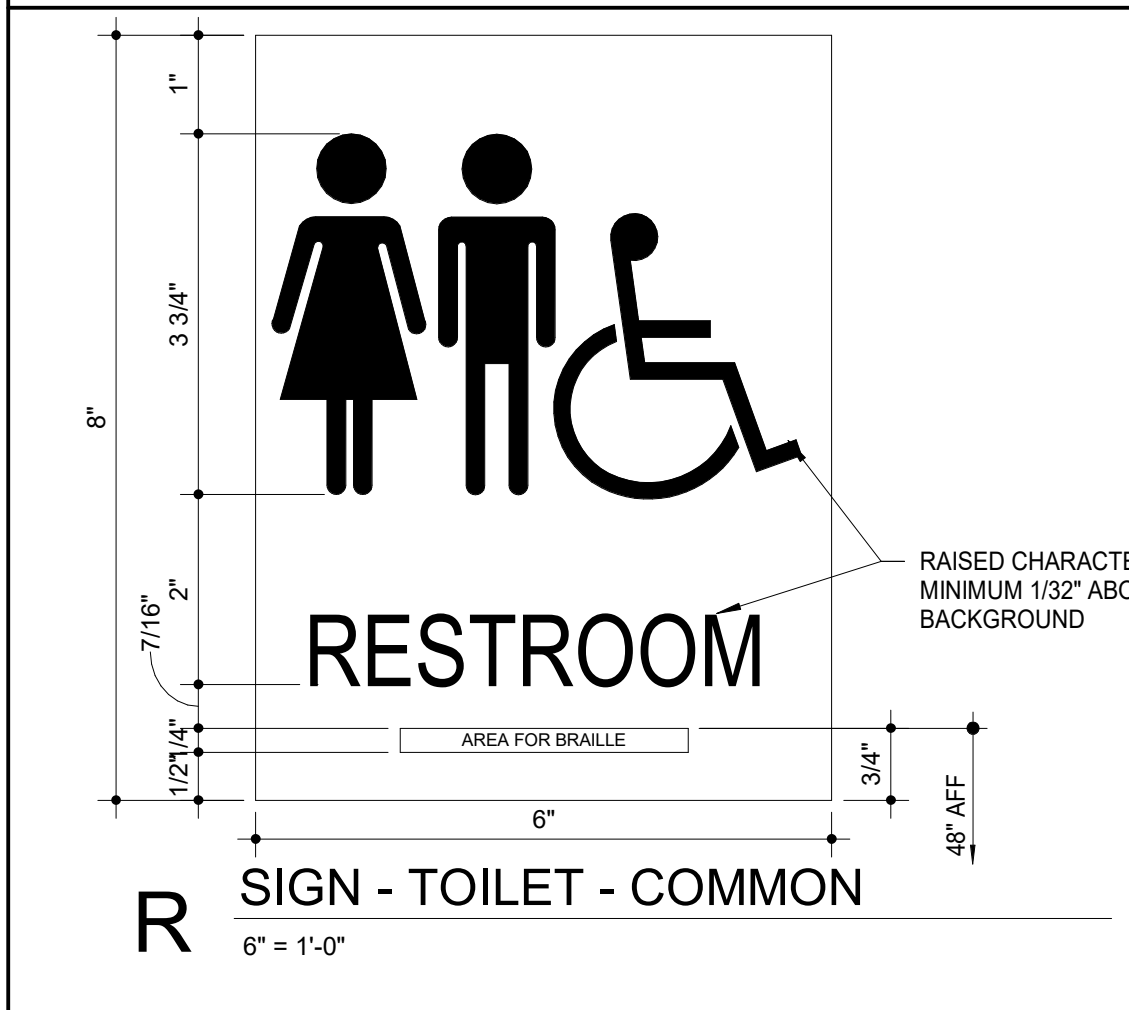

R SIGN - TOILET - COMMON
6" = 1'-0"

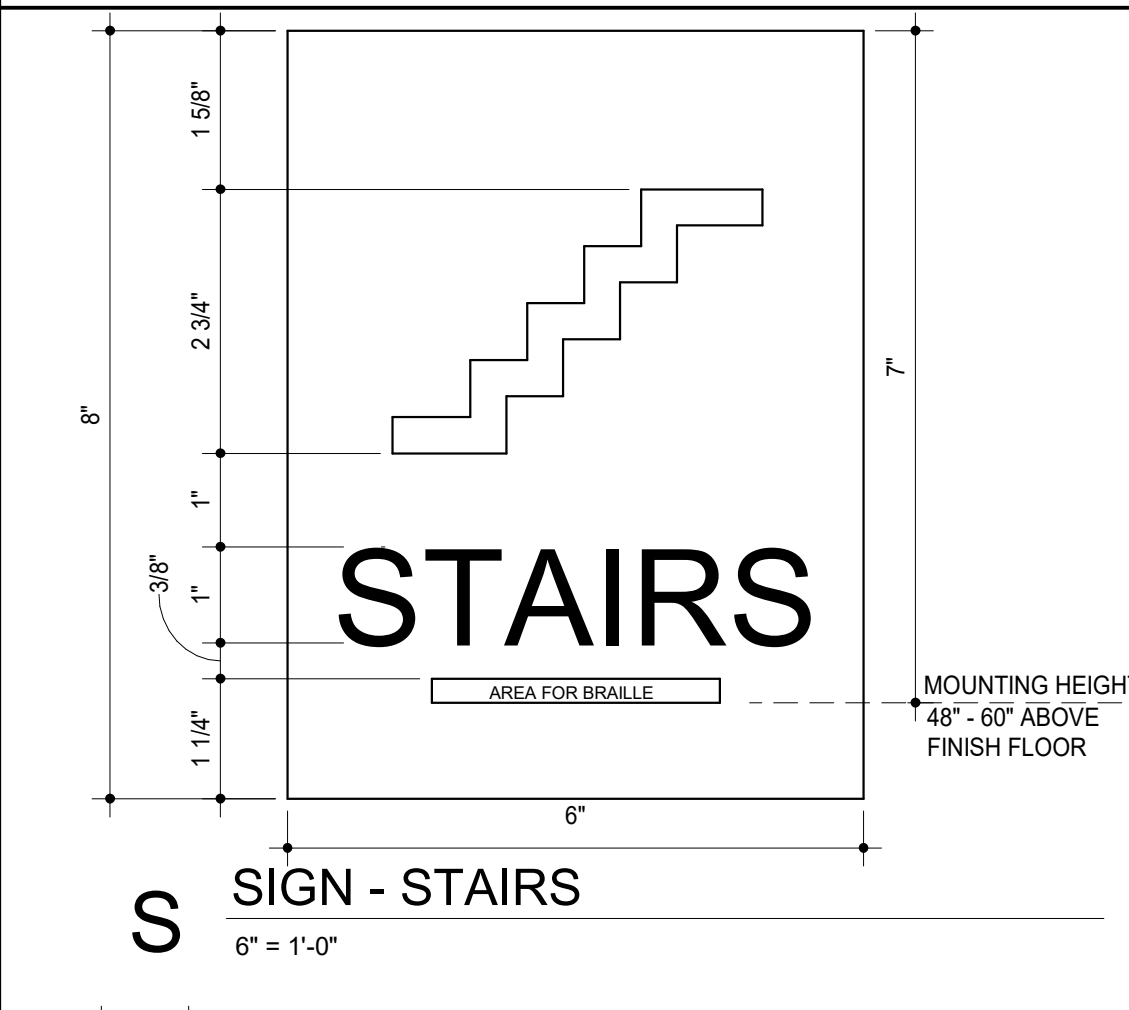

S SIGN - STAIRS
6" = 1'-0"

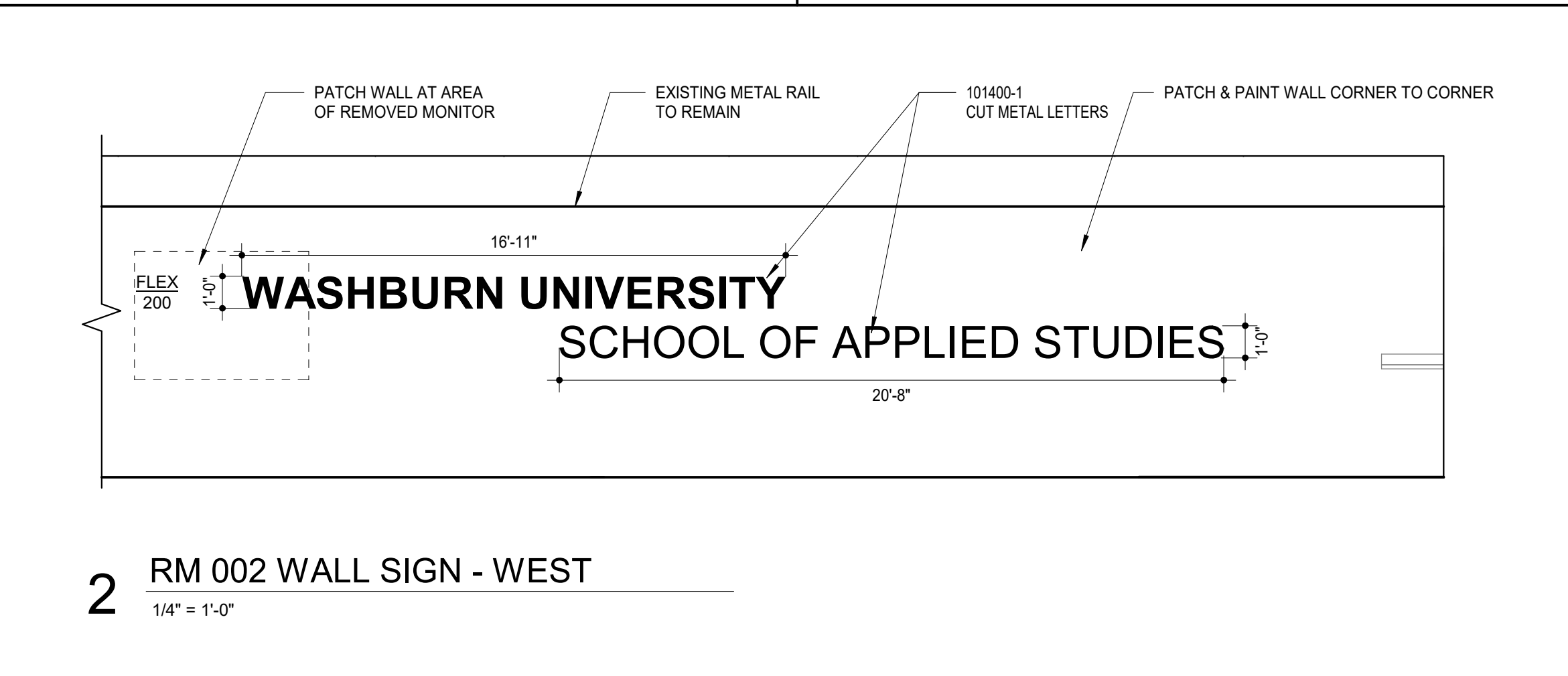

2 RM 002 WALL SIGN - WEST
1/4" = 1'-0"

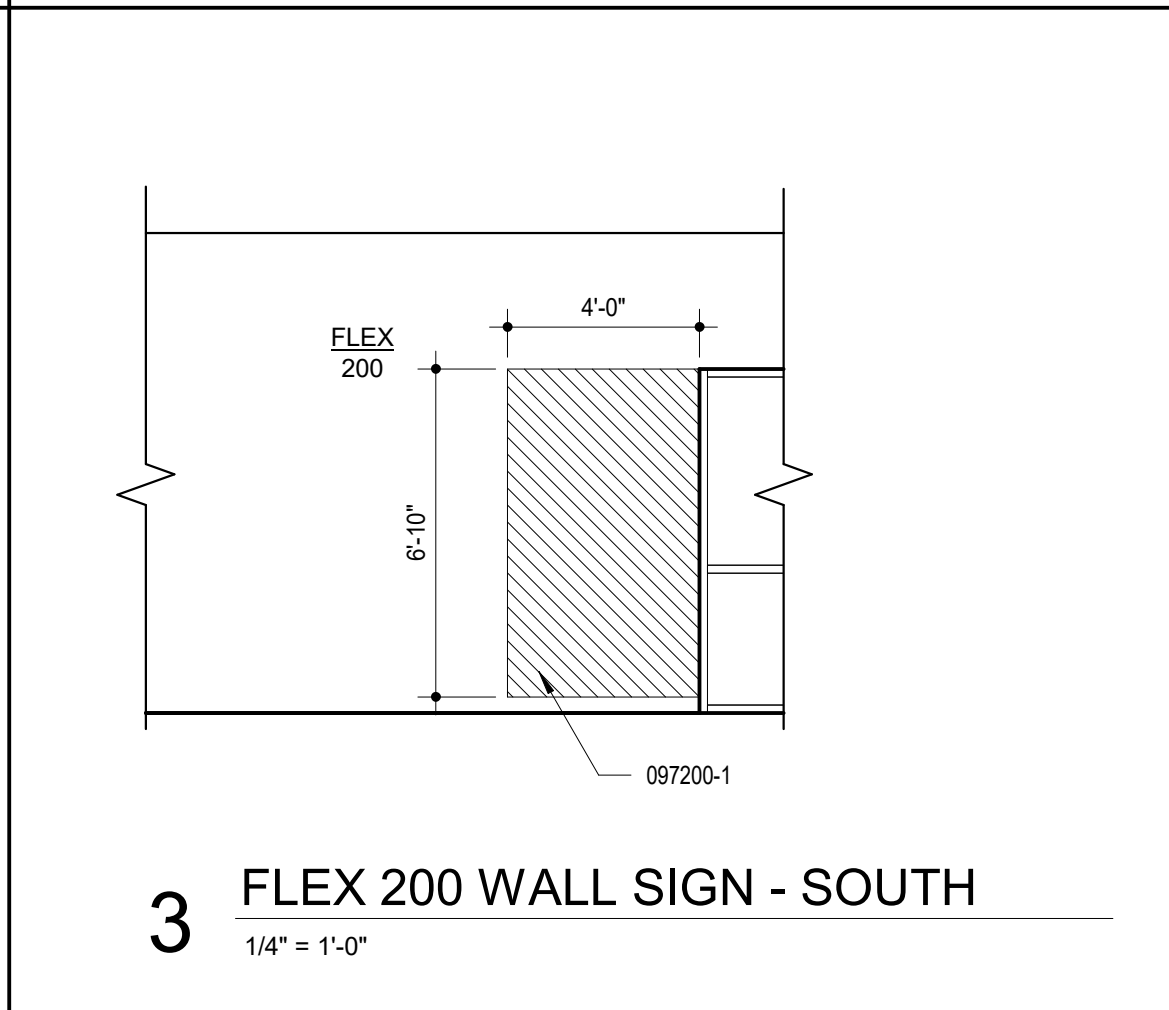

3 FLEX 200 WALL SIGN - SOUTH
1/4" = 1'-0"



F SIGN - IN CASE OF FIRE
6" = 1'-0"

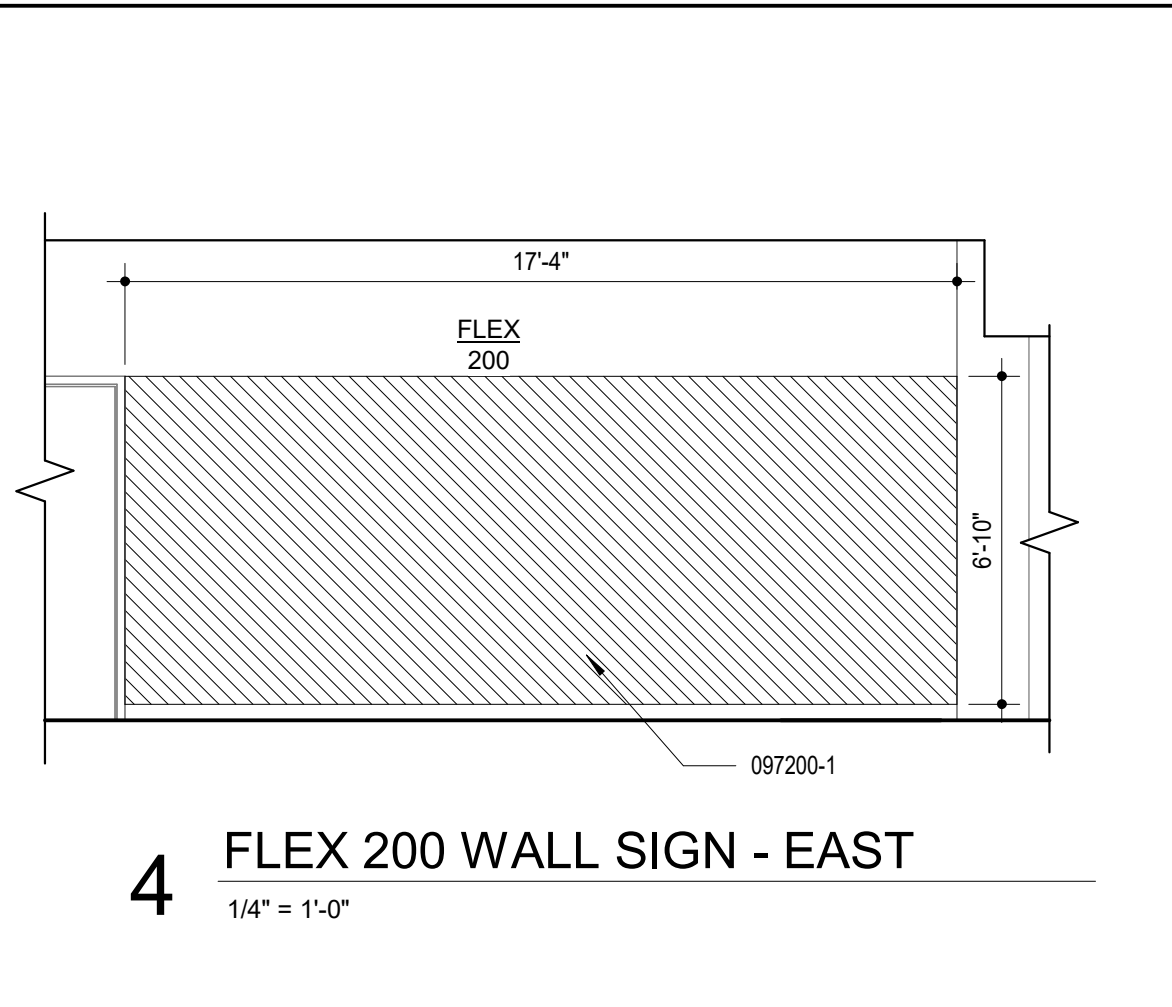

4 FLEX 200 WALL SIGN - EAST
1/4" = 1'-0"

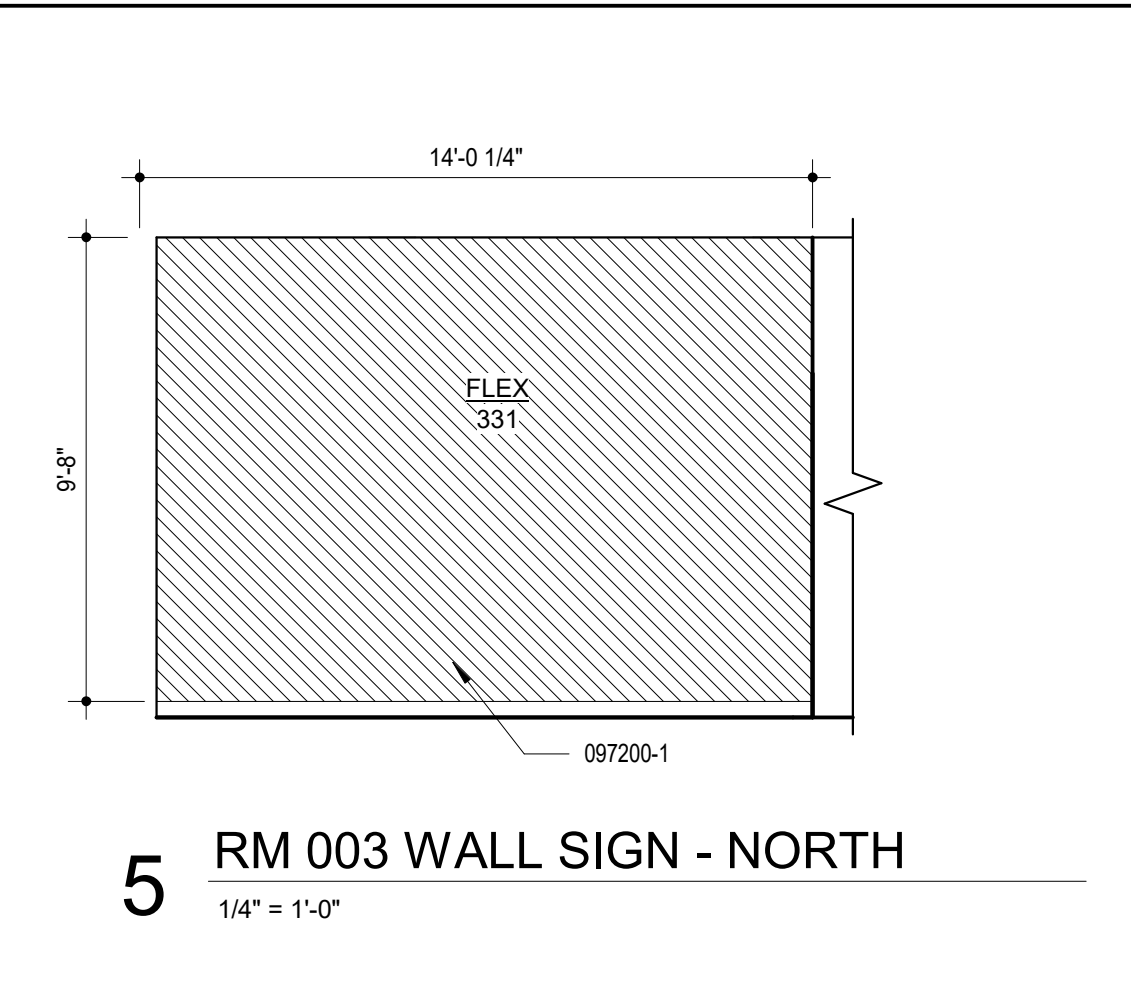

5 RM 003 WALL SIGN - NORTH
1/4" = 1'-0"

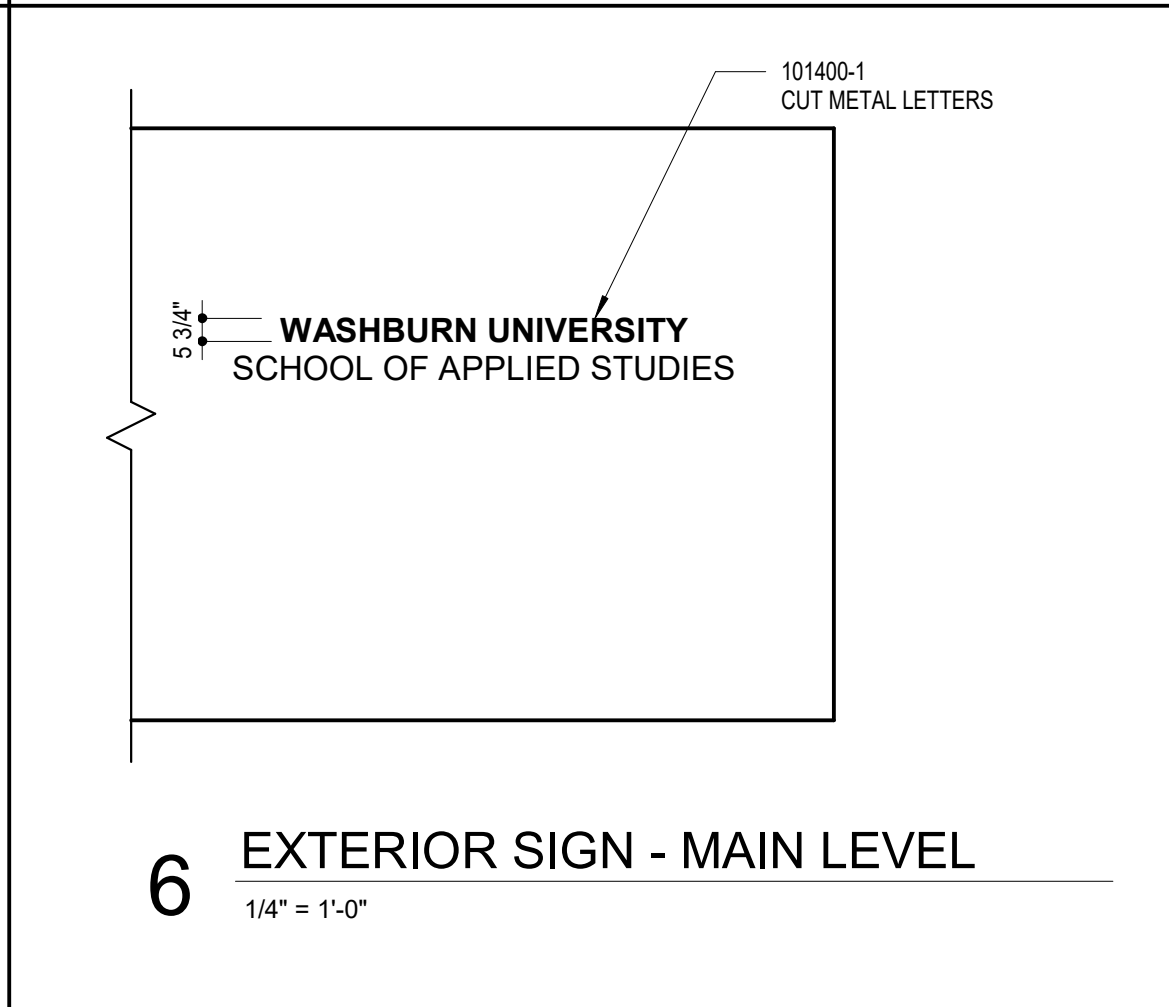

6 EXTERIOR SIGN - MAIN LEVEL
1/4" = 1'-0"

KEYNOTES

NOTE: KEYNOTES ARE DRAWN FROM A MASTER LIST AND MAY NOT BE SEQUENTIALLY NUMBERED. SIZES (EX. 2x4) OR OTHER INFO. FOLLOWING KEYNOTE ON DRAWINGS INDICATES CRITERIA FOR THOSE MATERIALS LOCATIONS WHICH MAY DIFFER FROM THE STD. MATERIAL SPECIFIED.

033000	-1 CONCRETE	092000	-1 GYPSUM BOARD (")
	-2 CONCRETE FLOOR SLAB	-2	FIRE RATED GYPSUM BOARD (")
	-3 VAPOR BARRIER	-3	CEMENTITIOUS TILE BACKER PANEL
	-4 WELDED WIRE FABRIC	-4	METAL SUSPENSION SYSTEM
050000	-5 STEEL REINFORCING BAR	-5	ACOUSTICAL SEALANT
	-6 STEEL ANGLE	-6	ACOUSTICAL INSULATION(1)
	-7 STEEL LINTEL	-7	METAL EDGE TRIM
061000	-8 2X WOOD BLOCKING (")	-8	AUXILIARY SUPPORT FRAMING
	-9 PLYWOOD BACKER	-9	HIGH IMPACT GYPSUM BOARD
064116	-10 PLASTIC LAMINATE	-10	INTERIOR FINISHING COMPOUND
	-11 FACED ARCHITECTURAL CABINET	093013	-2 GLAZED WALL TILE (")
	-12 CABINET LINER LAMINATE	-3	PORCELAIN FLOOR TILE (")
	-13 PLYWOOD	-4	METAL EDGE STRIP
	-14 3MM EDGE MOLDING	095113	-1 ACOUSTICAL PANEL (")
	-15 DOOR HINGE	-2	CEILING SUSPENSION SYSTEM
	-16 DOOR/DRAWER PULL	-3	EDGE MOLD TRIM
	-17 DRAWER	-4	AUXILIARY SUPPORT FRAMING
	-18 SHELF SUPPORTS	098513	-1 RESILIENT WALL BASE
	-19 COUNTERTOP SUPPORT BRACKET	-2	EDGE STRIP
072100	-4 BUILDING INSULATION - FACED (R.)	098516	-1 RESILIENT SHEET FLOORING
	-5 SILL SEALER	098518	-1 RESILIENT FLOOR TILE
	-6 SMILING INSULATION	098813	-1 CARPET TILE
076200	-1 SHEET METAL FLASHING AND COUNTERFLASHING	099200	-1 WALL COVERING
	-2 JOINT FILLER	099203	-1 INTERIOR PAINT
	-3 GASKET	101100	-1 MARKERBOARD
	-4 BACKER ROD	101400	-1 DIMENSIONAL LETTER SIGNAGE
081113	-2 HOLLOW METAL FRAME	102113-17	-1 PHENOLIC CORE TOILET COMPARTMENT
	-3 FRAME ANCHOR	-2	URINAL SCREEN
081416	-1 FLUSH WOOD DOOR	102600	-1 CORNER GUARD
081513	-1 ACCESS DOOR	-2	FRP IMPACT RESISTANT WALLCOVERING
084113	-1 ALUMINUM ENTRANCE DOOR	102800	-1 SOAP DISPENSER
	-2 ALUMINUM STOREFRONT FRAME	-2	TOILET TISSUE DISPENSER
	-3 DRYER	-3	PAPER TOWEL DISPENSER
	-4 DRYER	-4	FRAMED MIRROR
	-5 DRYER	-4	SANITARY NAPKIN DISPOSER
088000	-1 STEEL STUD (")	-7	GRAB BAR
	-2 STEEL STUD (")	-8	PARAPET CHANGING STATION
092216	-1 STEEL STUD (")	104413	-1 FIRE EXTINGUISHER CABINET
	-2 FURRING CHANNEL	120413	-1 ROLLER WINDOW SHADES
		123553-13-1	METAL LABORATORY CABINETS
		123661-16-1	SOLID SURFACE COUNTERTOP
		134900	-1 LEAD LINED GYP. BD. LEAD GLASS
		-2	HOLLOW METAL FRAME
		-3	LEAD LINED WOOD DOOR

- SIGN SCHEDULE GENERAL NOTES**
- THE ROOM NUMBER AND ROOM NAME TEXT ARE THE CHARACTERS TO BE PRINTED ON THE SIGN, U.N.O.
 - ALL SIGNS ADJACENT TO DOORS OR OPENINGS TO BE LOCATED ACCORDING TO DETAIL 1/A801
 - SIGNS LOCATED AT DOUBLE DOORS WITH TWO ACTIVE LEAFS ARE TO BE INSTALLED TO THE RIGHT OF THE RIGHT HAND DOOR.
 - WHERE THERE IS NO WALL SPACE AT THE LATCH SIDE OR THE RIGHT SIDE OF DOUBLE DOORS, SIGN IS TO BE LOCATED AT THE NEAREST ADJACENT WALL.
 - WHERE SIGNS ARE SHOWN ON GLASS, PROVIDE BACKPLATE BEYOND THE ARC OF ANY DOOR SWINGS BETWEEN THE CLOSED POSITION AND 45 DEGREE OPEN POSITION.
 - ALL INTERIOR AND EXTERIOR SIGNAGE TO BE INSTALLED PER MANUFACTURER'S RECOMMENDATIONS.
 - COORDINATE FINAL SIGNAGE WORDING AND NUMBERING PRIOR TO FABRICATION.
 - SIGNAGE SHALL BE COORDINATED WITH ADA REQUIREMENTS. ALL LETTERS, NUMERALS, PICTOGRAMS, AND BRAILLE LETTERS SHALL BE TYPE RAISED 1/32" FROM THE BACKGROUNDS, CAPITAL LETTERS ONLY WITH SHARP EDGES, U.N.O.
 - ALL SIGNAGE REQUIRING PICTOGRAMS SHALL HAVE A BORDER DIMENSION OF 6" TYP. (THE UNOBSTRUCTED FIELD WITHIN WHICH THE PICTOGRAM IS LOCATED).
 - ALL SIGNS DESIGNATING PERMANENT ROOMS AND SPACES SHALL BE LOCATED ADJ. TO THE STRIKE JAMB LATCH SIDE OF THE DOOR. IF WALL SPACE ADJACENT TO THE STRIKE JAMB IS NOT AVAILABLE, THEN THE SIGN SHALL BE PLACED ON THE NEAREST ADJ. WALL OR PARTITION, U.N.O. THE MOUNTING LOCATION SHALL BE SUCH THAT A PERSON CAN APPROACH TO WITHIN 3" OF THE SIGN WITHOUT ENCOUNTERING ANY PROTRUDING OBJECTS OR HAVING TO STAND WITH THE SWING OF THE DOOR. LOCATION OF SIGNS SHALL COMPLY WITH ALL APPLICABLE CODES.
 - REFER TO PLANS FOR SIGN LOCATION PLAN MARKS UNLESS ADDITIONALLY NOTED. SIGN PLAN MARKS ARE INDICATED AS: PANEL SIGNS BY ALLOWANCE, SHOWN TO ASSIST WITH ANTICIPATED ALLOWANCE AMOUNT, VINYL WALL GRAPHICS & DIMENSIONAL SIGNAGE TO BE INCLUDED IN BASE BID COST.

NOTES:
REFER TO SECTIONS AND DETAILS ON ALL OTHER SHEETS FOR APPLICABLE NOTES NOT SHOWN.



DATE: July 16, 2024

REVISED DATE:

SHEET CONTENTS:
SIGNAGE

HTK PROJECT NUMBER:
2312.03

SHEET NUMBER:
A801

TALL CABINETS:

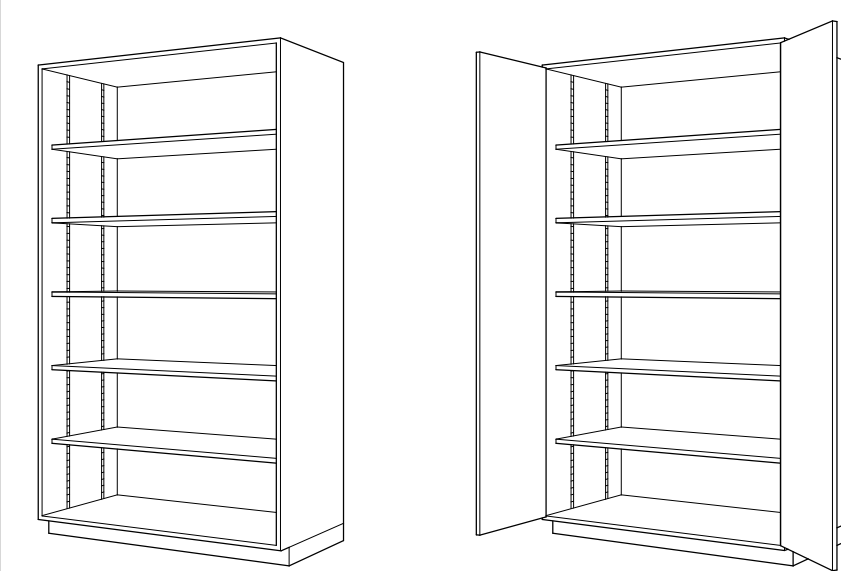

OPEN T1
j) 30w x 84h x 14d
p) 36w x 84h x 24d

DOOR T2
p) 36w x 84h x 24d

WALL CABINETS:

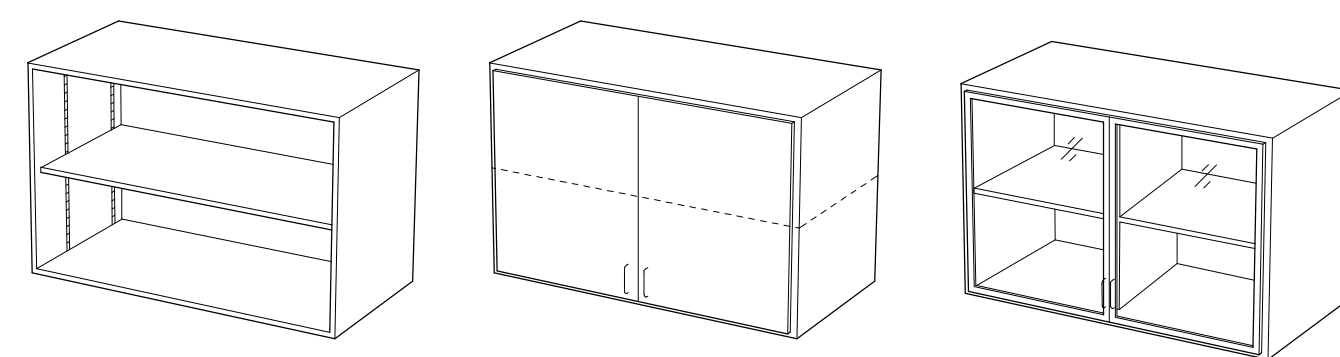

OPEN W1
E) 24w x 24h x 14d
p) 36w x 24h x 14d
q) 36w x 30h x 14d
l) 40w x 24h x 14d

DOOR W2
j) 30w x 24h x 14d
k) 30w x 30h x 14d
p) 36w x 24h x 14d
q) 36w x 30h x 14d
y) 48w x 24h x 14d

OPEN DIVIDED GLASS DOORS W3
p) 36w x 30h x 14d

BASE CABINETS:

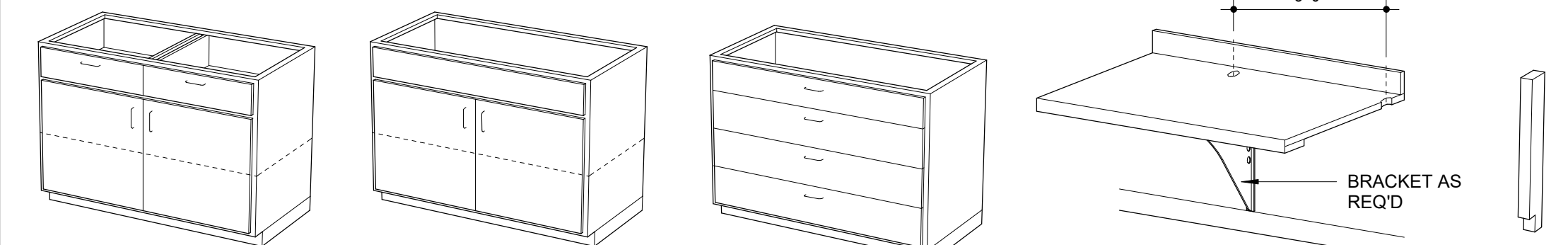

DOOR DRAWER B7
j) 30w x 34h x 24d
p) 36w x 34h x 24d

SINK B8
j) 30w x 34h x 24d
p) 36w x 34h x 24d
y) 48w x 34h x 24d

DRAWER B11
p) 36w x 34h x 24d

OPEN COUNTER KNEE-SPACE KS
3'-0"

FILLER F

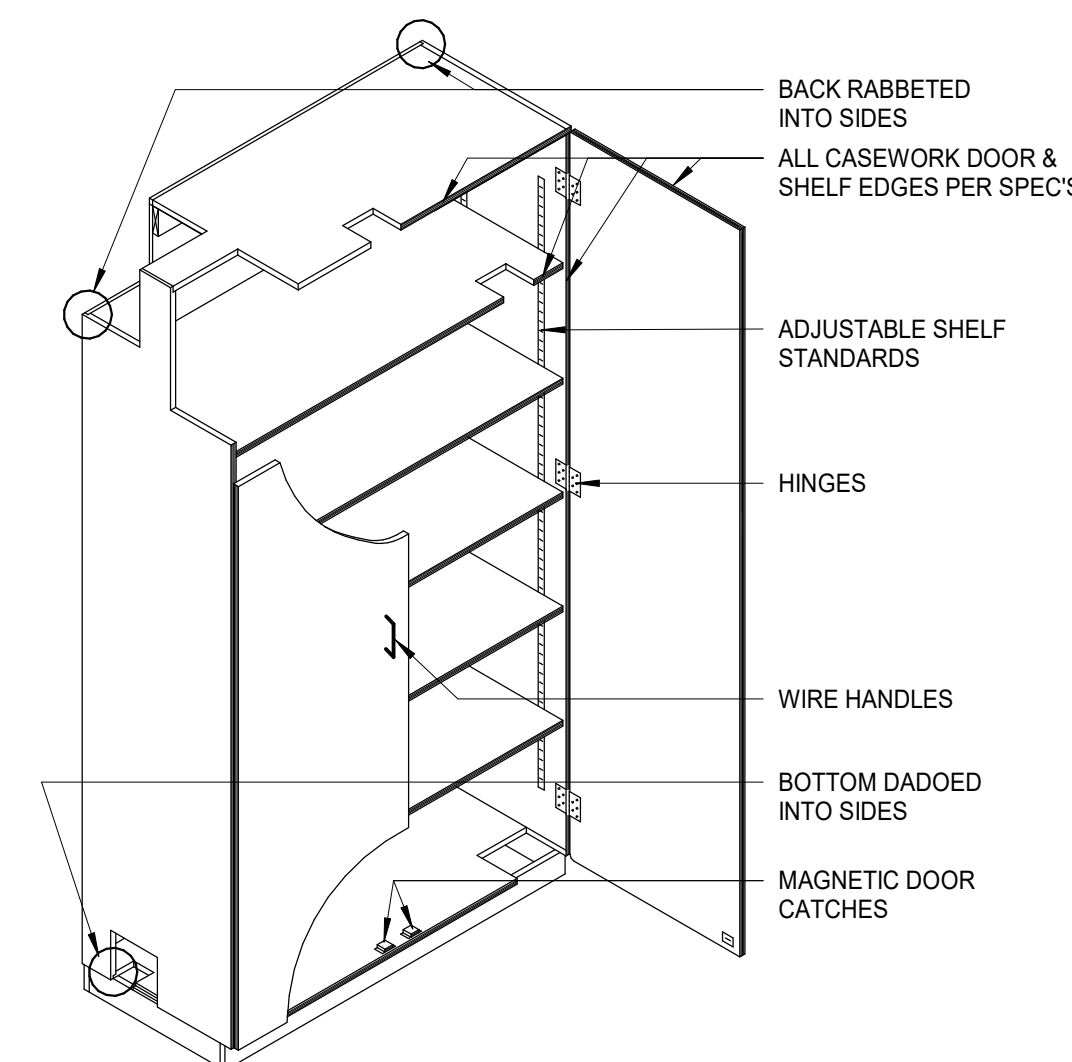

1 TYP. TALL CABINET
3" = 1'-0"

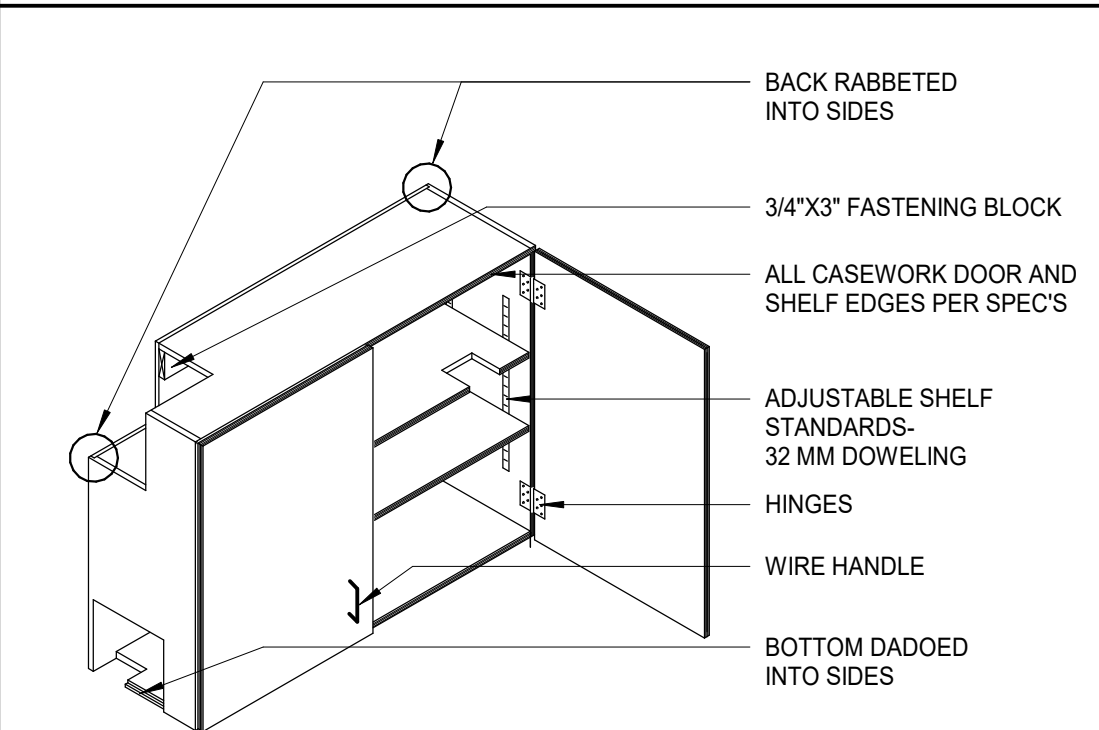

2 TYP. WALL CABINET
3" = 1'-0"

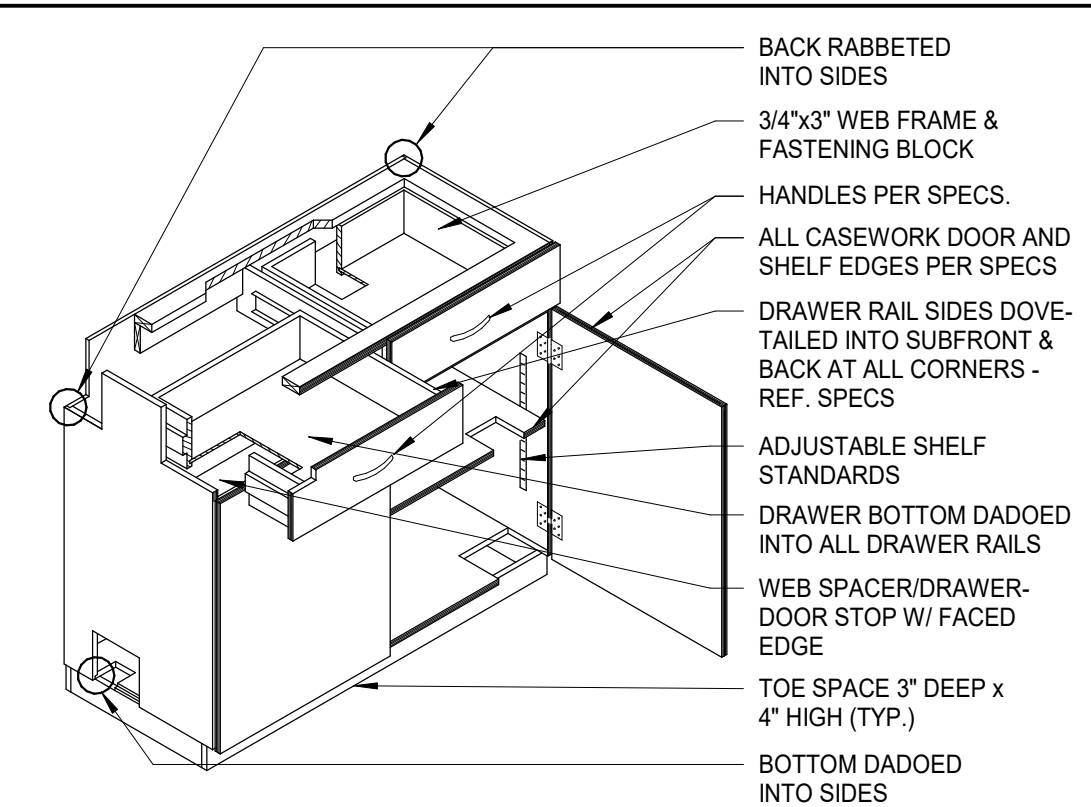

3 TYP. BASE CABINET
3" = 1'-0"

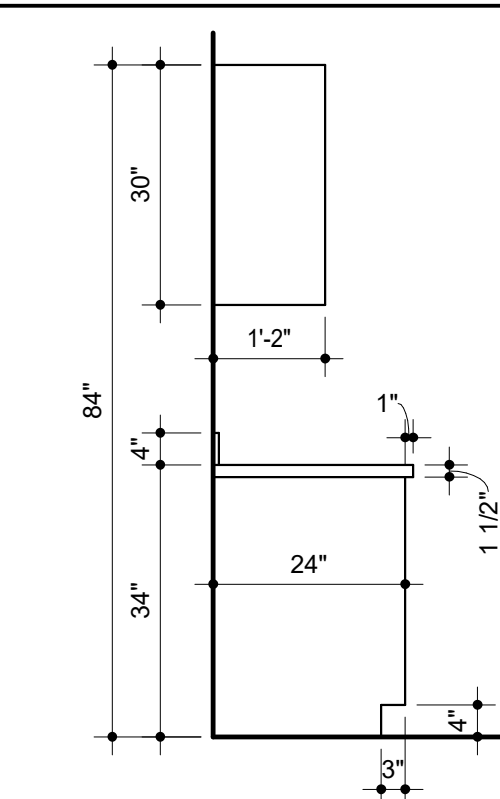

4 TYP. CASEWORK ELEVATIONS
1/2" = 1'-0"

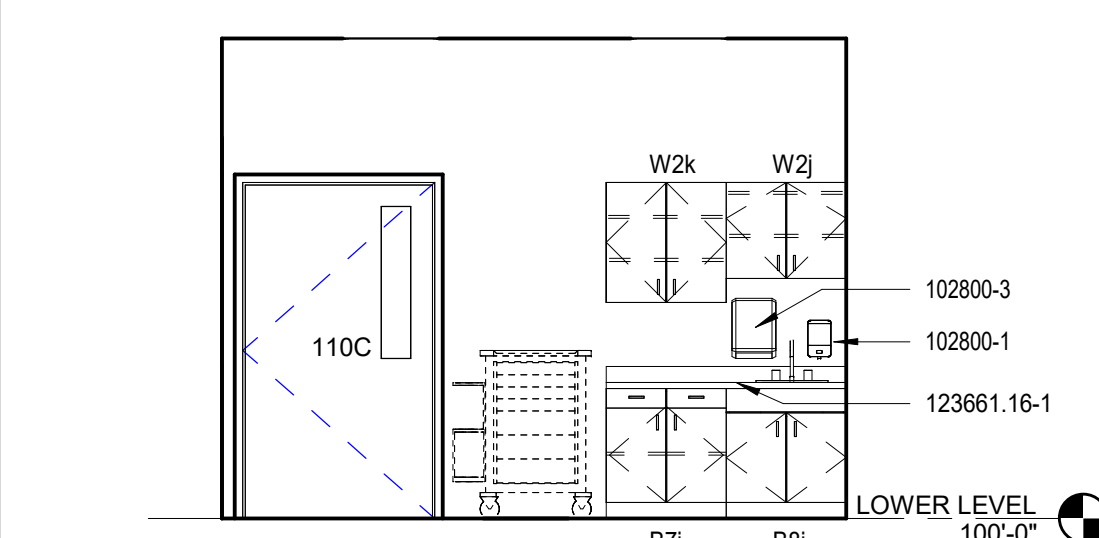

5 SIM LAB 118A - WEST ELEV.
1/4" = 1'-0"

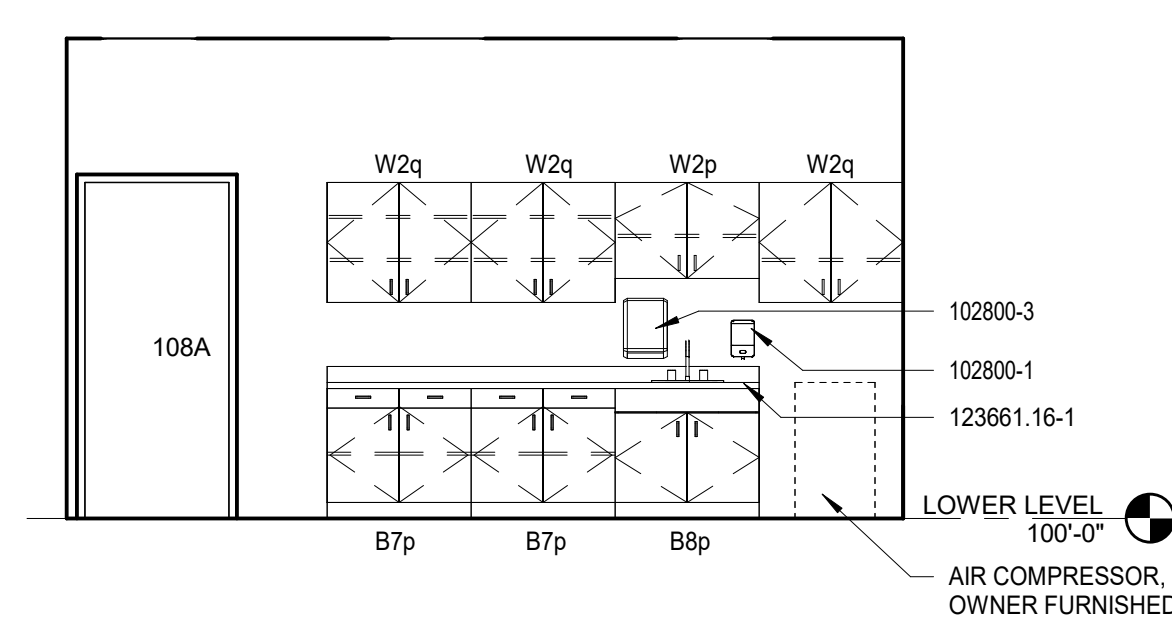

6 PREP 118B - WEST ELEV.
1/4" = 1'-0"

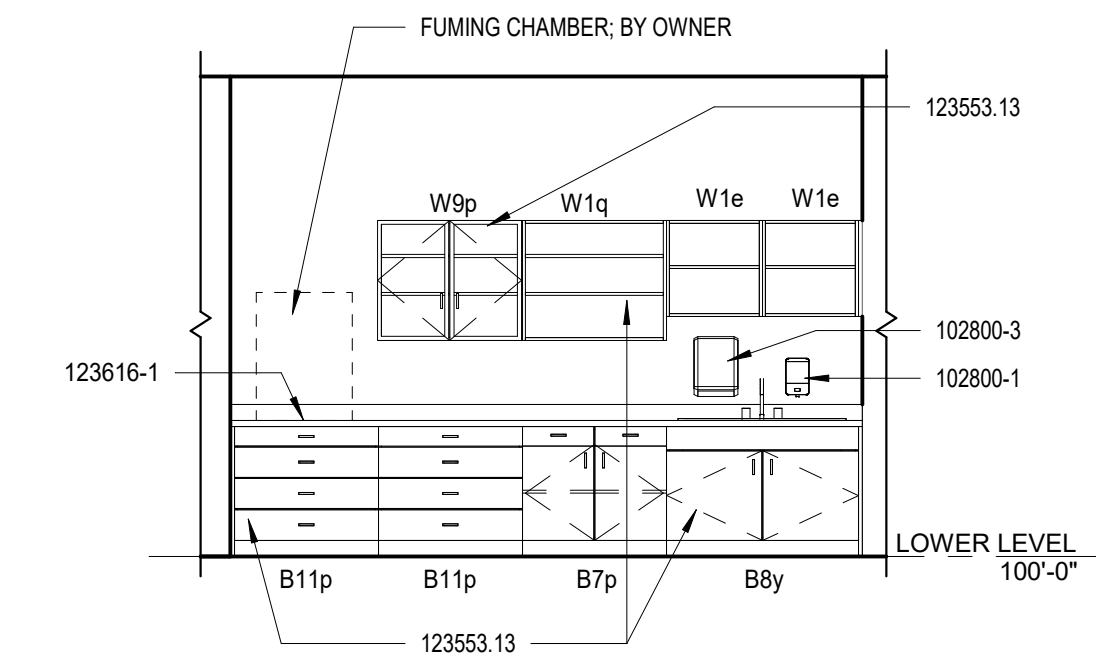

7 FORENSIC LAB 119 - SOUTH ELEV.
1/4" = 1'-0"

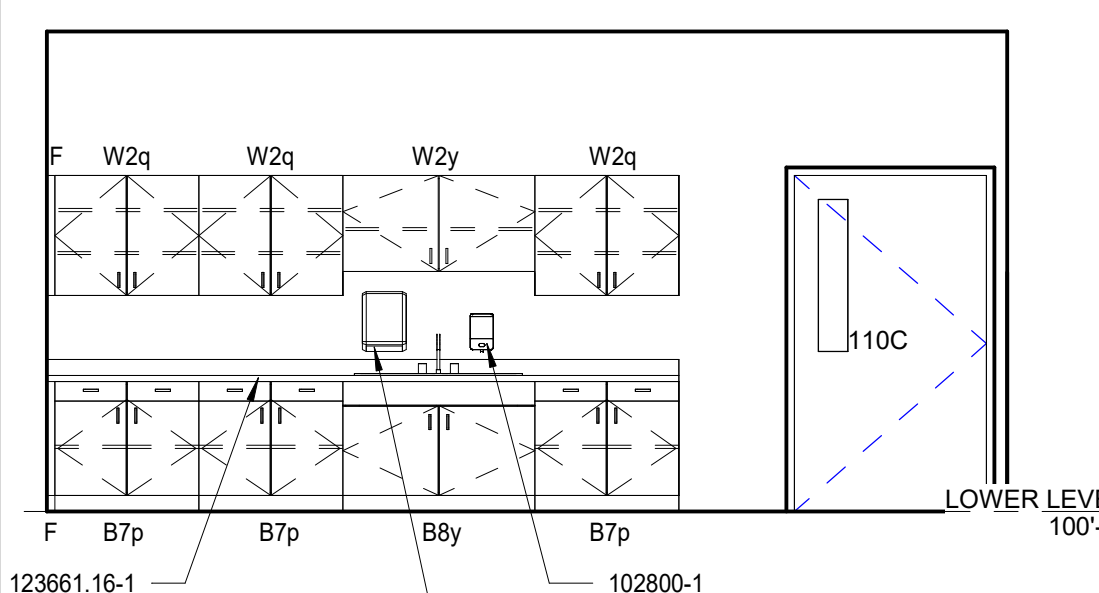

8 SHARED LAB/STOR 119A - EAST ELEV.
1/4" = 1'-0"

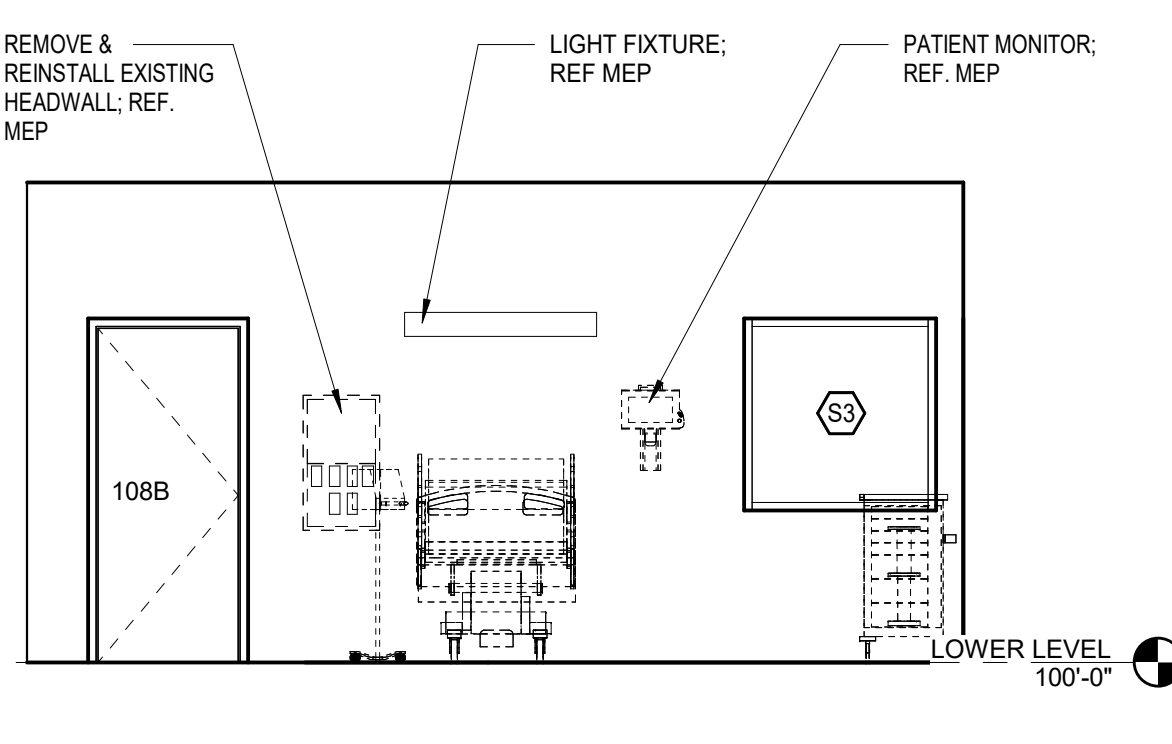

9 SIM LAB 118A HEADWALL
1/4" = 1'-0"

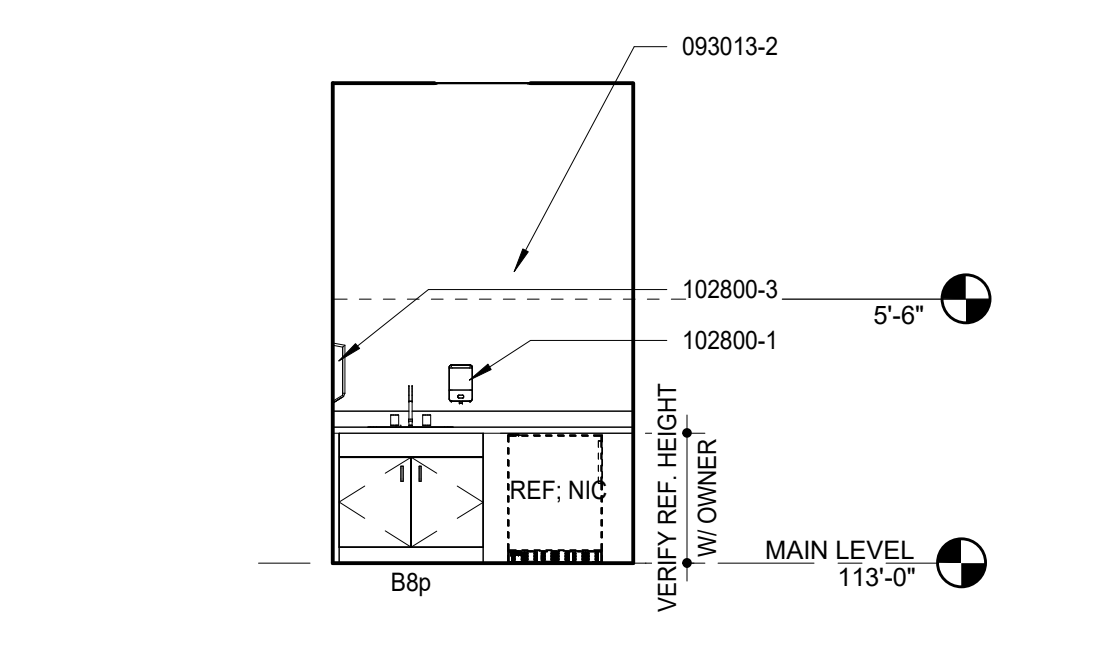

10 WELLNESS 002A - SOUTH ELEV.
1/4" = 1'-0"

KEYNOTES

NOTE: KEYNOTES ARE DRAWN FROM A MASTER LIST AND MAY NOT BE SEQUENTIALLY NUMBERED. SIZES (EX. 24") OR OTHER INFO FOLLOWING KEYNOTE ON DRAWINGS INDICATES CRITERIA FOR THOSE MATERIALS/ LOCATIONS WHICH MAY DIFFER FROM THE STD. MATERIAL SPECIFIED.

030000	-1	CONCRETE	092900	-1	GYPSUM BOARD (")
	-2	CONCRETE FLOOR SLAB	-2	FIRE RATED GYPSUM BOARD (")	
	-3	VAPOR BARRIER	-3	CERAMITIC TILE BACKER PANEL	
	-4	WELDED WIRE FABRIC	-4	METAL SUSPENSION SYSTEM	
050000	-5	STEEL REINFORCING BAR	-5	ACOUSTICAL SEALANT	
	-1	STEEL ANGLE	-6	ACOUSTICAL INSULATION(")	
	-8	STEEL LINTEL	-7	METAL EDGE TRIM	
	-8	STEEL PLATE	-8	AUXILIARY SUPPORT FRAMING	
061000	-2	2X WOOD BLOCKING (")	-10	HIGH IMPACT GYPSUM BOARD	
	-4	PLYWOOD BACKER	-11	INTERIOR FINISHING COMPOUND	
064116	-1	FACED ARCHITECTURAL CABINETS	093013	-2	GLAZED WALL TILE (")
	-3	CABINET LINER LAMINATE	-4	PORCELAIN FLOOR TILE (")	
	-5	PLYWOOD	-9	METAL EDGE STRIP (")	
	-6	3MM EDGE MOLDING	095113	-1	ACOUSTICAL PANEL (")
	-10	DOOR HINGE	-2	CEILING SUSPENSION SYSTEM	
	-11	DOOR/DRAWER PULL	-3	EDGE MOLD TRIM	
	-12	MAGNETIC CATCH	-4	AUXILIARY SUPPORT FRAMING	
	-13	DRAWER	095613	-1	RESILIENT WALL BASE
	-14	SHelf SUPPORT	-2	EDGE STRIP	
	-15	COUNTERTOP SUPPORT	095616	-1	RESILIENT SHEET FLOORING
072100	-4	BUILDING INSULATION - BRACKET	098513	-1	RESILIENT FLOOR TILE
	-5	SILL SEALER	098513	-1	CARPET TILE
	-6	SAFING INSULATION - FACED (R)	099123	-1	INTERIOR PAINT
072100	-4	BUILDING INSULATION - JOINT FILLER	101100	-1	MARKERBOARD
	-5	SILL SEALER	101100	-1	TACKBOARD
072000	-1	JOINT SEALANT - RAKE	101400	-1	DIMENSIONAL LETTER SIGNAGE
	-2	JOINT FILLER	102113.1X	-1	PHENOLIC CORE TOILET COMPARTMENT
	-3	GASKET	102800	-1	CORNER GUARD
	-4	BACKER ROD	102800	-1	SOAP DISPENSER
081113	-2	HOLLOW METAL FRAME	102800	-1	WALLCOVERING
	-3	FRAME ANCHOR	102800	-1	TOILET TISSUE DISPENSER
081416	-1	FLUSH WOOD DOOR	102800	-1	PAPER TOWEL DISPENSER
083113	-1	ACCESS DOOR	102800	-1	FRAMED MIRROR
	-2	ACCESS DOOR FRAME	102800	-1	SANITARY NAPKIN DISPOSER
084113	-1	ALUMINUM ENTRANCE DOOR	104113	-1	DIAPER CHANGING STATION
	-2	ALUMINUM STOREFRONT FRAME	122413	-1	FIRE EXTINGUISHER CABINET
088000	-1	GLAZING (AS SCHEDULED)	122413	-1	ROLLER WINDOW SHADES
092216	-1	STEEL STUD (")	123553.13	-1	METAL LABORATORY CASEWORK
	-2	STEEL STUD RUNNER (")	123616.1	-1	SOLID SURFACE COUNTERTOP
	-3	FURRING CHANNEL	134900	-1	LEAD LINED OVP. BD
			134900	-2	LEAD GLASS
			134900	-3	HOLLOW METAL FRAME
			134900	-4	LEAD LINED WOOD DOOR



DATE: July 16, 2024
 REVISED DATE:

SHEET CONTENTS:
 • FIXED EQUIPMENT ELEVATIONS & DETAILS
 HTK PROJECT NUMBER:
 • 2312.03

SHEET NUMBER:
FE101
 ORIGINAL CONTRACT DOCUMENTS

MECHANICAL SYMBOLS LEGEND			
	WATER CLOSET & TYPE (TYP. FOR ALL PLUMBING FIXTURES)		CHILLED HOT SUPPLY
	WASTE LINE ABOVE EARTH (W.)		CHILLED HOT RETURN
	WASTE LINE IN EARTH (W.)		UNION
	CLEAN OUT		FLEXIBLE PIPE CONNECTION
	FLUSH FLOOR CLEAN OUT		MANUAL DAMPER
	FLUSH GRADE CLEAN OUT		BACKDRAFT DAMPER
	FLOOR DRAIN AND TYPE		AUTOMATIC DAMPER
	ROOF DRAIN		FIRE DAMPER
	OVERFLOW ROOF DRAIN		FIRE/SMOKE DAMPER
	ROOF DRAIN AND TYPE		SMOKE DAMPER
	VENT LINE (V.)		GRILLE, REGISTER OR DIFFUSER, SIZE, TYPE & CFM
	DOMESTIC COLD WATER SUPPLY (DOW)		VOLUME EXTRACTOR AND TURNING VANES
	DOMESTIC HOT WATER SUPPLY (DHW)		RETURN, EXHAUST OR FRESH AIR DUCT SECTION UP & DOWN
	DOMESTIC HOT WATER RETURN (DHW/R)		SUPPLY AIR DUCT SECTION UP AND DOWN
	HOSE BIBBS AND MOUNTING HEIGHT		FLEXIBLE DUCT CONNECTION
	WALL HYDRANT		ROUND OR RECTANGULAR DUCT
	FIRE LINE STANDPIPE		FLEXIBLE DUCT
	DRAIN LINE		THERMOSTAT
	NATURAL GAS LINE		REFRIGERANT LIQUID/SUCTION
	RISE & DROP IN PIPE WITH OUT-OFF VALVE		ACCESS DOOR
	REDUCER		ABOVE FINISHED FLOOR
	CHECK VALVE		EXHAUST AIR
	STOP VALVE		OUTSIDE AIR
	BALANCING VALVE/AUTO/FLOW VALVE		RETURN AIR
	PLUG VALVE		SUPPLY AIR
	2-WAY CONTROL VALVE OR SOLENOID VALVE		VENT BELOW SLAB
	3-WAY CONTROL VALVE OR SOLENOID VALVE		VENT THRU ROOF
	PRESSURE REDUCING VALVE		CONNECT NEW TO EXISTING
	STRAINER		LOCKABLE GUARD
	CHILLED WATER SUPPLY		VARIABLE FREQUENCY DRIVE
	CHILLED WATER RETURN		EUI
	HOT WATER SUPPLY		DSS, COOLING ONLY
	HOT WATER RETURN		DSS, HEATING/COOLING

NOTES: ALL SYMBOLS SHOWN ABOVE MAY NOT APPEAR ON PLANS.

NFPA SYMBOLS LEGEND	
	SMOKE DETECTOR
	SMOKE DETECTOR WITH SOUNDER BASE
	SMOKE DETECTOR WITH ISOLATOR BASE
	HEAT DETECTOR
	DUCT DETECTOR
	ADDRESSABLE MANUAL PULL STATION
	DOOR HOLDER
	FLOW DETECTOR/SWITCH
	TAMPER DETECTOR
	TEST STATION
	MR101C SHUTDOWN RELAY, SPDT WIRED
	AV (WALL MOUNTED) 24 VDC
	STROBE
	BELL ANNUNCIATOR
	HORN/SPEAKER
	FIRE ALARM CONTROL PANEL
	FIREMAN'S PHONE
	AREA RESCUE CALL STATION
	AREA RESCUE MASTER STATION
	SIGNAL ZAM
	CONTROL ZAM
	DETECTOR ZAM
	MONITOR MODULE
	RELAY IAM
	GRAPHIC COMMAND CENTER
	REMOTE FIRE ALARM AUDIO
	REMOTE ANNUNCIATOR WITH AUDIO
	ANNUNCIATOR
	FIRE SMOKE DAMPER
	NAC POWER EXTENDER

* ALL SYMBOLS SHOWN ABOVE MAY NOT APPEAR ON PLANS

ELECTRICAL SYMBOLS LEGEND			
	CONDUIT CONCEALED IN CEILING OR WALL (1 HOT, 1 NEUTRAL, 1 GROUND UNLESS NOTED OTHERWISE)		LOCKABLE GUARD
	CONDUIT CONCEALED IN FLOOR SLAB		JUNCTION BOX
	EXPOSED CONDUIT		SWITCH - SINGLE POLE
	HOMERUN - ARROW INDICATES CKT. LINES INDICATE WIRES		SWITCH - 3-WAY
	GROUND WIRE		SWITCH - 4-WAY
	GROUNDING ROD		SWITCH - MOTION
	SINGLE RECEPTACLE		WALL DIMMER IS LUTRON NOVA T INTSTV-DV, 0-10V, 27V, SLIDE DIMMER
	DUPLEX RECEPTACLE (20 AMP UNLESS NOTED)		CEILING MOUNTED, MOTION SENSING SWITCH
	DUPLEX RECEPTACLE WITH USB OUTLETS		LIGHT FIXTURE AND TYPE
	SWITCHED DUPLEX RECEPTACLE		EMERGENCY LIGHT FIXTURE WITH BATTERY PACK
	FOURPLEX RECEPTACLE		FIXTURE ON LIFE SAFETY BRANCH OF EMERGENCY SYSTEM
	208 OR 240 VOLT RECEPTACLE (20 AMP UNLESS NOTED)		LIGHT FIXTURE (WALL MOUNTED)
	GROUND FAULT INTERRUPTER (GFI) DUPLEX RECEPTACLE		EXIT LIGHT (CEILING OR WALL MOUNTED)
	TELEDATA OUTLET		FLUSH PANELBOARD (LIGHT & RECEPTACLES)
	PUSHBUTTON		SURFACE PANELBOARD (LIGHT & RECEPTACLES)
	VARIABLE FREQUENCY DRIVE		DISTRIBUTION PANEL OR SWITCHBOARD
	OVERRIDE TIMER		DEVICE LOCATED ABOVE COUNTER
	PHOTOZELL		ABOVE FINISHED FLOOR
	MOTOR		DIMMER
	FUSIBLE SWITCH (BUSSMAN SSI)		CEILING
	DISCONNECT SWITCH (D.S.)		INDICATES EXISTING DEVICE
	COMBINATION MOTOR STARTER (CMS)		BELOW COUNTER
	RELAY		NIGHTLIGHT FIXTURE, WIRED NOT
	THERMOSTAT		WEATHERPROOF
			ARC FAULT CIRCUIT INTERRUPTER
			CONNECT NEW TO EXISTING

NOTES: ALL SYMBOLS SHOWN ABOVE MAY NOT APPEAR ON PLANS. REFER TO MECHANICAL SYMBOLS LEGEND FOR MECHANICAL SYMBOLS THAT MAY BE SHOWN ON ELECTRICAL PLANS. * 4x4 BACKBOX WITH SINGLE GANG PLASTER RING AND A 1 1/4" CONDUIT TO ABOVE ACCESSIBLE CEILING.

TELECOMMUNICATIONS CABLE IDENTIFIER		
SYMBOL	DESCRIPTION	REMARKS
	TELECOMMUNICATIONS OUTLET WITH ROOM AND TYPE IDENTIFIER	1
	TELECOMMUNICATIONS OUTLET WALL PHONE PLATE	2
	AUDIOVISUAL OUTLET	3
	TELEVISION OUTLET	1
	EMT CONDUIT BY EIC (1 1/4" UNLESS NOTED OTHERWISE)	4
	EMT SLEEVE BY EIC (2" UNLESS NOTED OTHERWISE)	4
	ABOVE FINISHED FLOOR	
	TELECOMMUNICATIONS CONTRACTOR	
	ELECTRICAL CONTRACTOR	
	GENERAL CONTRACTOR	
	DEVICE LOCATED ABOVE COUNTER	
	TELECOMMUNICATIONS MAN GROUNDING BUSBAR	
	TELECOMMUNICATIONS GROUNDING BUSBAR	
	TELECOMMUNICATIONS CABLING	5
	FIRE ALARM CONTROL PANEL	
	SINGLEMODE FIBER	
	MULTIMODE FIBER	
	WIRELESS ACCESS POINT	6

TELECOM ROOM: D201A OUTLET TYPE

1 - 4x4 STEEL CITY BACKBOX, MODEL NUMBER 7217-1-1/4 W/ SINGLE GANG PLASTER RING AND 1 1/4" CONDUIT TO ABOVE ACCESSIBLE CEILING AS INDICATED ON DRAWINGS BY EIC.
2 - 2x4 BACKBOX WITH 3/4" CONDUIT TO ABOVE ACCESSIBLE CEILING.
3 - 4x4 STEEL CITY BACKBOX, MODEL NUMBER 7217-1-1/4 WITH DOUBLE GANG PLASTER RING BY EIC. CONDUITS AS INDICATED ON PLANS.
4 - EIC TO PROVIDE CONDUIT BUSHING ON CONDUIT PRIOR TO TIC INSTALLING CABLING.
5 - CABLING SHALL BE SUPPORTED WITH J-HOOKS AT 48" O.C. WHERE NOT IN CONDUIT.
6 - 2x4 SURFACE MOUNT BACKBOX LOCATED ABOVE ACCESSIBLE CEILING.

AUDIO/VISUAL LEGEND		
SYMBOL	DESCRIPTION	REMARKS
	AUDIOVISUAL OUTLET	1
	AUDIOVISUAL FLOORBOX/PORKE-THRU (REFER TO ELECTRICAL DRAWINGS)	
	TOUCH SCREEN CONTROL PANEL	
	OVERHEAD PROJECTOR	
	AUDIOVISUAL SPEAKER	
	VOLUME CONTROL	
	MICROPHONE	
	EMT CONDUIT BY EIC (1 1/4" UNLESS NOTED OTHERWISE)	2
	EMT SLEEVE BY EIC (2" UNLESS NOTED OTHERWISE)	2
	DUPLEX RECEPTACLE	
	FOURPLEX RECEPTACLE	
	AUDIOVISUAL CABLING	3
	ABOVE FINISHED FLOOR	
	AUDIOVISUAL CONTRACTOR	
	TELECOMMUNICATIONS CONTRACTOR	
	ELECTRICAL CONTRACTOR	
	GENERAL CONTRACTOR	
	DEVICE LOCATED ABOVE COUNTER	
	SINGLEMODE FIBER	
	MULTIMODE FIBER	

1 - 4x4 STEEL CITY BACKBOX, MODEL NUMBER 7217-1-1/4 WITH DOUBLE GANG PLASTER RING AND 1 1/4" CONDUIT TO ABOVE ACCESSIBLE CEILING BY EIC.
2 - EIC TO PROVIDE CONDUIT BUSHING ON CONDUIT PRIOR TO TIC INSTALLING CABLING.
3 - CABLING SHALL BE SUPPORTED WITH J-HOOKS AT 48" O.C. WHERE NOT IN CONDUIT.

SECURITY LEGEND	
SYMBOL	DESCRIPTION
	ACCESS CONTROL PANEL
	ACCESS CONTROL PANEL POWER SUPPLY
	HD CARD READER
	REQUEST TO EXIT *
	DOOR POSITION SWITCH *
	ELECTRIC LOCK *
	DOOR POWER SUPPLY *
	PUSH BUTTON
	MOTION DETECTOR
	GLASS BREAKER SENSOR
	ADA PUSH BUTTON *
	DUAL ADA PUSH BUTTON *
	ADA MOTORIZED OPERATOR *
	VIDEO INTERCOM DOOR STATION
	MASTER VIDEO INTERCOM STATION
	BURGLAR INTRUSION DETECTION PANEL
	VIDEO SURVEILLANCE CAMERA
	NETWORK VIDEO RECORDER
	PAN/TILT/ZOOM

* - INDICATES PROVIDED BY DOOR HARDWARE SUPPLIER. REFER TO DOOR HARDWARE SPECIFICATIONS FOR FURTHER WIRING/POWER REQUIREMENTS.

PAGING LEGEND		
SYMBOL	DESCRIPTION	REMARKS
	PAGING SYSTEM	
	CEILING PAGING SPEAKER	
	WALL MOUNTED PAGING SPEAKER	
	PAGING HORN	
	VOLUME CONTROL	

GENERAL NOTES: PIPING	
1. PROVIDE 3M OR EQUIVALENT FIRE STOP AT ALL RATED WALL AND FLOOR PENETRATIONS. SEE CODE PLAN.	18. MINIMUM SLOPE OF WASTE PIPING SHALL BE 1/8" PER FT. VERIFY ELEVATIONS WITH NEW WASTE SERVICES. REFER TO CIVIL PLANS.
2. DO NOT ROUTE PIPING OVER ELECTRICAL EQUIPMENT OR WITHIN NEC CLEARANCE REQUIREMENTS. COORDINATE EQUIPMENT INSTALLATION, ROUTING AND LOCATION WITH WORK OF OTHER TRADES.	19. ALL INDIVIDUAL VENT PIPING SHALL BE 2" UNLESS NOTED OTHERWISE.
3. COORDINATE ACCESS TO VALVES AND OTHER ABOVE CEILING EQUIPMENT WITH LUMINAIRES, ETC.	20. ROUTE ROOF DRAIN PIPING IN JOIST WEBBING WHERE POSSIBLE. COORDINATE WITH OTHER PIPE AND DUCTWORK SLOPE AT A MINIMUM OF 1/8" PER LINEAR FOOT.
4. ALL RAIN PIPING RUNS TO SINGLE PLUMBING FIXTURES SHALL BE 1/2" UNLESS NOTED OTHERWISE.	21. PROVIDE 1" FIBERGLASS INSULATION ON ALL ROOF DRAIN PIPING.
5. ALL PIPING SHALL BE TIGHT TO STRUCTURE UNLESS NOTED OTHERWISE OR AS REQUIRED FOR COORDINATION. FIELD COORDINATE AND PROVIDE OFFSETS AS REQUIRED.	22. INSULATE ALL DOMESTIC WATER PIPING WITH MINIMUM 1" FIBERGLASS INSULATION.
6. ALL VALVES SHALL BE LOCATED ABOVE ACCESSIBLE CEILING. WHERE VALVES ARE LOCATED ABOVE HARD CEILING, AN 18" X 18" MINIMUM ACCESS PANEL SHALL BE PROVIDED BY GC. REFER TO ARCHITECTURAL.	23. SUPPORT ALL PIPE FROM STRUCTURE.
7. NOT ALL OFFSETS AND DROPS ARE SHOWN ON PLANS. COORDINATE WITH ALL OTHER TRADES, EXISTING TRADES, STRUCTURE, AND INSTALL AS REQUIRED.	24. IN EXPOSED AREAS, SADDLES SHALL BE SECURED TO INSULATION.
8. REFER TO SPECIFICATION FOR PIPE LABELING REQUIREMENTS.	25. COORDINATE LOCATION OF FLOOR DRAINS WITH EQUIPMENT (WATER HEATERS, ETC.).
9. ALL EXPOSED PIPING AND/OR INSULATED PIPING SHALL BE FIELD PAINTED TO MATCH ADJACENT SURFACES UNLESS IN MECHANICAL ROOMS. COORDINATE WITH ARCHITECTURAL.	26. ALL ROOF DRAIN/VERRELOW DRAIN ASSEMBLIES ARE TYPE-1, 4" OUTLETS, UNLESS NOTED OTHERWISE.
10. ALL PIPING SHALL BE CONCEALED UNLESS NOTED OTHERWISE. ANY PIPING THAT MAY NEED TO BE EXPOSED DUE TO FIELD CONDITIONS SHALL BE COORDINATED WITH ARCHITECT AND ENGINEER PRIOR TO INSTALLATION.	27. INSULATE ALL ROOF DRAIN BODIES WITH 1" BLACK CLOSED CELL INSULATION.
11. ALL PLUMBING VENTS SHALL BE A MINIMUM OF 15 FT. FROM OUTSIDE AIR OPENINGS, INTAKE LOUVERS, PENTHOUSES, ETC. FIELD ROUTE AS REQUIRED.	28. HOLE PENETRATIONS IN EXISTING WALLS SHALL BE REVIEWED WITH STRUCTURAL PRIOR TO INSTALLATION. A MINIMUM SEPARATION OF TWICE THE LARGEST HOLE DIAMETER SHALL BE REQUIRED BETWEEN ADJACENT PENETRATIONS.
12. SUPPORT, SUSPENSION, OR HANGING OF ALL PIPING AND METHODS SHALL BE REVIEWED WITH STRUCTURAL PRIOR TO INSTALLATION.	
13. REFER TO ARCHITECTURAL PLANS FOR FIXTURE MOUNTING HEIGHTS, ADA CLEARANCES, CONTROL LOCATIONS, ETC.	
14. ALL PIPE INSULATION SYSTEMS SHALL MAINTAIN PROPER VAPOR BARRIER AS SPECIFIED. TAPE AND SEAL ALL JOINTS AND COVERS ACCORDINGLY. ALL ELBOWS AND FITTING COVERS SHALL BE IMMEDIATELY PLACED WITH INSULATION.	
15. ALL SINKS AND PLUMBING FIXTURES SCHEDULED FOR INSTALLATION IN BASE CABINETS OR OTHER MILLWORK SHALL BE COORDINATED WITH MILLWORK SHOP DRAWINGS PRIOR TO PURCHASE. VERIFY CLEARANCES, INSTALLATION AND FIT ACCORDINGLY. REPORT DEVIATIONS TO ARCHITECT AND ENGINEER FOR REVIEW.	

GENERAL NOTES: HVAC DUCTWORK	
1. ALL NEW DUCTWORK SHALL BE EXTERNALLY WRAP INSULATED EXCEPT TRANSFER OR SOUND BOOTHS WHICH SHOULD HAVE INTERNAL LINING. ALL EXISTING SUPPLY DUCTWORK SHALL REMAIN AS IS (UNINSULATED SPIRAL) AT THIS TIME. DUCTWORK SHALL BE THOROUGHLY CLEANED INSIDE AND OUT AND PAINTED AS SCHEDULED.	
2. ALL LOW PRESSURE DUCT RUN OUTS SHALL BE SAME SIZE AS DIFFUSER NECK. ROUTE IN JOIST SPACE AND THROUGH JOISTS WHERE POSSIBLE.	
3. PROVIDE 3M EQUIVALENT FIRE STOP AT ALL CORRIDOR WALL PENETRATIONS. REFER TO FIRE DAMPER DETAIL AND SPECIFICATIONS.	
4. DO NOT ROUTE DUCTWORK OVER ELECTRICAL EQUIPMENT OR WITHIN NEC CLEARANCE REQUIREMENTS.	
5. COORDINATE DUCTWORK INSTALLATION, ROUTING AND LOCATION WITH WORK OF OTHER TRADES. COORDINATE ACCESS TO COALS, VAN BOOTHS AND OTHER ABOVE CEILING EQUIPMENT. PROVIDE DUCTWORK OFFSETS WHERE REQUIRED.	
6. COORDINATE ROUTING OF DUCTWORK AND PIPING BETWEEN AND THRU JOISTS OR STRUCTURE.	
7. ROUTE ALL DUCTWORK TIGHT TO BOTTOM OF STRUCTURE UNLESS NOTED OTHERWISE.	
8. COORDINATE EXACT LOCATIONS OF DUCTWORK AND PIPING WITH THROUSSES, LIGHT FIXTURES, AND ANY OTHER DISCIPLINE.	
9. EXHAUST DUCTS SHALL NOT BE INTERNALLY INSULATED. ALL JOINTS SHALL BE SEALED WITH WATER-BASED SEALANT.	
10. ALL EXPOSED DUCTWORK TO BE PAINTED EXCEPT THOSE IN STORAGE ROOMS OR MECHANICAL ROOMS.	
11. ALL ROUND DUCT SHALL HAVE CONCENTRIC REDUCERS WHERE APPLICABLE.	
12. ALL LOW PRESSURE CONCEALED ROUND DUCT SHALL BE SINGLE WALL SPIRAL, EXTERNAL INSULATED, EXCEPT EXHAUST. LONGITUDINAL SEAM DUCTWORK IS ACCEPTABLE FOR ROUND DUCTS 18" OR SMALLER.	
13. ALL LOW PRESSURE DUCT CONNECTIONS SHALL BE SEALED WITH WATER-BASED SEALANT OR EQUIVALENT.	

GENERAL NOTES: POWER	
1. NO ELECTRICAL PANELS SHALL BE INSTALLED BELOW PIPING, DUCTWORK, OR MECHANICAL EQUIPMENT. REFER TO MECHANICAL PLANS FOR LOCATIONS.	
2. FIELD COORDINATE FINAL LOCATION OF ALL EQUIPMENT WITH MECHANICAL TO MAINTAIN NEC CLEARANCES.	
3. REFER TO FIRE ALARM PLANS FOR ADDITIONAL WORK AND ROOM-IN REQUIREMENTS.	
4. PROVIDE ALL SWITCHBOARDS, DPS, TRANSFORMERS AND OTHER FREESTANDING ELECTRICAL GEAR WITH 3 1/2" CONCRETE HOUSEKEEPING PADS UNLESS NOTED OTHERWISE.	
5. ALL CONDUCTORS #12 THIN IN 1/2" C. UNLESS NOTED OTHERWISE.	
6. VERIFY ALL FINAL LOCATION AND ELEVATION OF ALL WALL-MOUNTED EQUIPMENT, OUTLETS, DATA, PHONE LOCATIONS, ETC. WITH CASEWORK, OWNER AND ARCHITECTURAL. CONFIRM DEDICATED OUTLETS, WITH OWNER.	
7. VERIFY ALL POWER, WIRING, RECEPTACLES, CIRCUIT, OVERCURRENT PROTECTION AND DATA REQUIREMENTS FOR ALL OWNER FURNISHED ITEMS SUCH AS COPIERS, REFRIGERATORS, TVS, STAFF ROOM APPLIANCES ETC.	
8. PROVIDE DATA AND POWER CORO GROMMET PENETRATIONS AT CORNERS OF ALL WORKSTATIONS TO ACCOMMODATE RECEPTACLES AND DATA MOUNTED BELOW COUNTERS. DEVICES SHALL BE BELOW COUNTERS EXCEPT WHERE NOTED OTHERWISE. COORDINATE WITH GC.	
9. REFER TO TELECOM "T" SHEETS AND AUDIO VISUAL "AV" SHEETS FOR ADDITIONAL WORK, RESPONSIBILITIES, ROOM-IN REQUIREMENTS, COORDINATION, ETC. THE ELECTRICAL "E" SHEETS ARE NOT INTENDED TO SHOW THE COMPLETE SCOPE OF WORK OR INSTALLATION REQUIREMENTS OF THESE SYSTEMS. ALL SHEETS AND DISCIPLINES MUST BE REVIEWED. ALL EQUIPMENT MATERIALS AND TOTAL SCOPE OF WORK FOR COMPLETE AND OPERATIONAL SYSTEMS SHALL BE INCLUDED IN THE CONTRACTORS BID PRICE.	
10. ALL EXPOSED CEILING CONDUIT RUNS WITHIN THE RECTIL HALL SHALL BE RUN ABOVE THE CLOUDS. MAIN RUNS SHALL RUN EAST/WEST TO CENTRAL CLOUD BEFORE ROUTING DOWN BEHIND STONE WALL.	



DATE: July 15, 2024
REVISED DATE:

ALL SYMBOLS SHOWN MAY NOT APPEAR ON THIS PROJECT

7/16/2024 11:53:11 AM Autodesk Docs://Mabee Library R23 - LSA MEP/Mabee Library MEP R23.rvt



1 MAIN LEVEL FLOOR PLAN
DEMOLITION
1/8" = 1'-0"

- LEGEND:
- ① DEMO ALL EXISTING LIGHT FIXTURES, CONTROLS, AND CONDUCTORS IN UNSHADED AREA, UNLESS OTHERWISE SPECIFIED.
 - ② REMOVE AND SALVAGE EXISTING LIGHT FIXTURE TO OWNER.
 - ③ DEMO EXISTING AUDIO EQUIPMENT.
 - ④ DEMO EXISTING SMOKE DETECTORS IN UNSHADED AREA, UNLESS OTHERWISE SPECIFIED.
 - ⑤ DEMO EXISTING MOTION SENSOR.
 - ⑥ DEMO EXISTING CAMERA.
 - ⑦ DEMO EXISTING SUPPLY AIR DIFFUSER AND ASSOCIATED DUCTWORK. REFER TO M102 FOR DETAILS ON RE ROUTING.
 - ⑧ DEMO EXISTING RETURN GRILLE AND ASSOCIATED DUCTWORK. REFER TO M102 FOR DETAILS FOR DETAILS ON RE ROUTING.
 - ⑨ DEMO EXISTING WIFI UNIT.
 - ⑩ DEMO EXISTING PULL STATION.
 - ⑪ DEMO ALL EXISTING POWER RECEPTACLES, TELECOMS, J-BOXES, ETC IN THIS AREA UNLESS OTHERWISE NOTED.
 - ⑫ DEMO EXISTING THERMOSTAT.
 - ⑬ DEMO EXISTING HANDICAPPED DOOR SYSTEM.
 - ⑭ DEMO EXISTING DRINKING FOUNTAIN.
 - ⑮ REUSE EXISTING DRINKING FOUNTAIN IN SAME LOCATION.
 - ⑯ DEMO EXISTING FIRE ALERT HORN OR FLASH.
 - ⑰ DEMO WIRE MOLD AND EXISTING POWER RECEPTACLES, TELECOMS, J-BOXES, ETC. ON WIRE MOLD.
 - ⑱ EXISTING, TO REMAIN.



DATE:
 • July 15, 2024

REVISED DATE:
 •
 •
 •

MABEE LIBRARY RENOVATION

Washburn University
 1800 SW 19th Street, Topeka, KS 66621



SHEET CONTENTS:
 • MAIN LEVEL FLOOR PLAN
 - DEMOLITION

HTK PROJECT NUMBER:
 • 2312.03

SHEET NUMBER:
ME102

ORIGINAL CONTRACT DOCUMENTS

7/16/2024 11:53:12 AM Autodesk Docs://Mabee Library R23 - LSA MEP/Mabee Library MEP R23.rvt

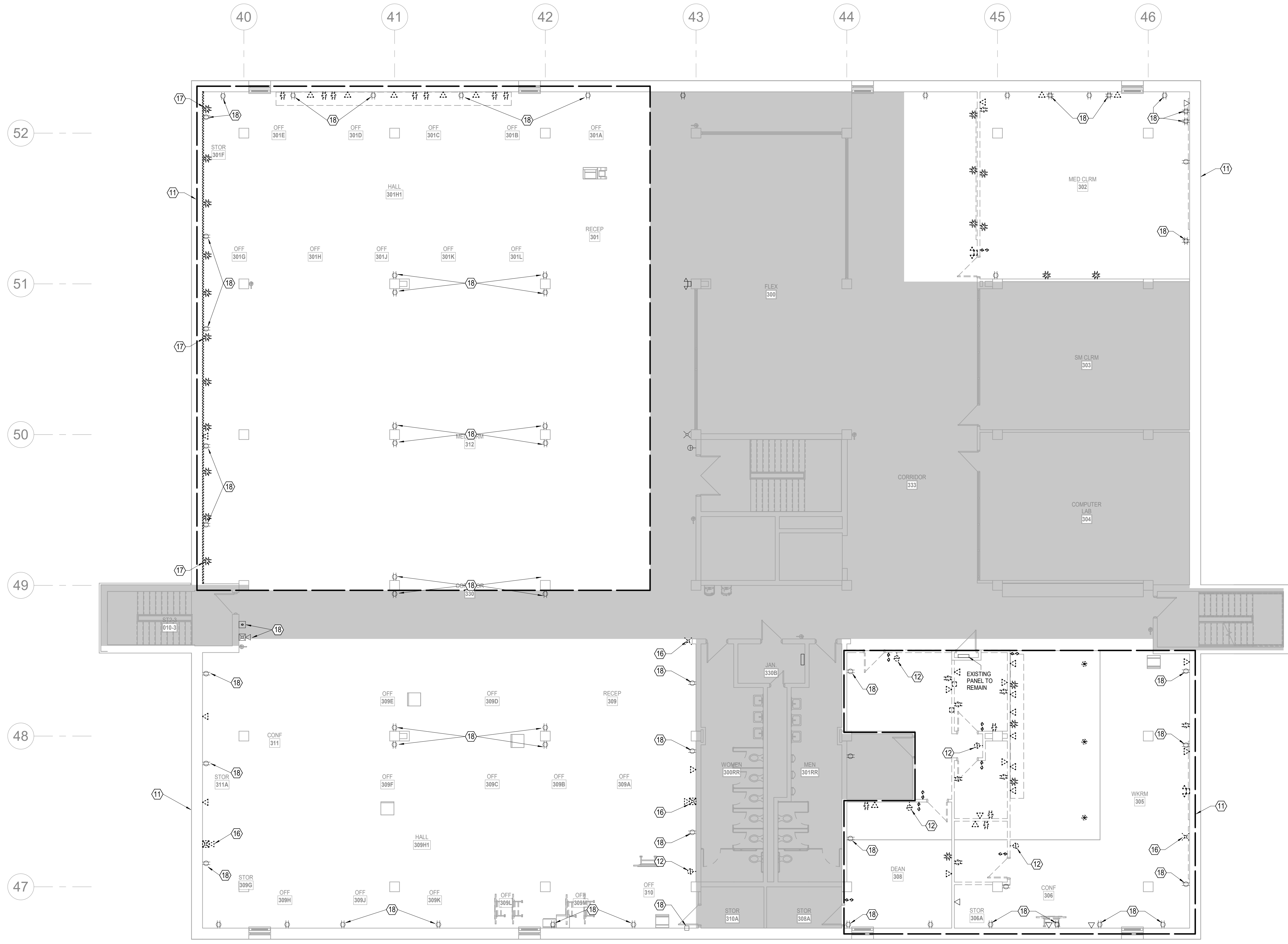

1 UPPER LEVEL FLOOR PLAN
DEMOLITION
1/8" = 1'-0"

- LEGEND:**
- ① DEMO ALL EXISTING LIGHT FIXTURES, CONTROLS, AND CONDUCTORS IN UNSHADED AREA, UNLESS OTHERWISE SPECIFIED.
 - ② REMOVE AND SALVAGE EXISTING LIGHT FIXTURE TO OWNER.
 - ③ DEMO EXISTING AUDIO EQUIPMENT.
 - ④ DEMO EXISTING SMOKE DETECTORS IN UNSHADED AREA, UNLESS OTHERWISE SPECIFIED.
 - ⑤ DEMO EXISTING MOTION SENSOR.
 - ⑥ DEMO EXISTING CAMERA.
 - ⑦ DEMO EXISTING SUPPLY AIR DIFFUSER AND ASSOCIATED DUCTWORK. REFER TO M102 FOR DETAILS ON RE ROUTING.
 - ⑧ DEMO EXISTING RETURN GRILLE AND ASSOCIATED DUCTWORK. REFER TO M102 FOR DETAILS FOR DETAILS ON RE ROUTING.
 - ⑨ DEMO EXISTING WIFI UNIT.
 - ⑩ DEMO EXISTING PULL STATION.
 - ⑪ DEMO ALL EXISTING POWER RECEPTACLES, TELECOMS, J-BOXES, ETC IN THIS AREA UNLESS OTHERWISE NOTED.
 - ⑫ DEMO EXISTING THERMOSTAT.
 - ⑬ DEMO EXISTING HANDICAPPED DOOR SYSTEM.
 - ⑭ DEMO EXISTING DRINKING FOUNTAIN.
 - ⑮ REUSE EXISTING DRINKING FOUNTAIN IN SAME LOCATION.
 - ⑯ DEMO EXISTING FIRE ALERT HORN OR FLASH.
 - ⑰ DEMO WIRE MOLD AND EXISTING POWER RECEPTACLES, TELECOMS, J-BOXES, ETC. ON WIRE MOLD.
 - ⑱ EXISTING, TO REMAIN.



DATE:
• July 15, 2024

REVISED DATE:
•
•
•

MABEE LIBRARY RENOVATION

Washburn University
1800 SW 19th Street, Topeka, KS 66621

SHEET CONTENTS:
• UPPER LEVEL FLOOR PLAN - DEMOLITION

HTK PROJECT NUMBER:
• 2312.03

SHEET NUMBER:
ME103

ORIGINAL CONTRACT DOCUMENTS

LS&A
 CONSULTING ENGINEERS
 Letitia Summers & Associates P.A.
 3839 SW Sumnerfield Drive, Suite A
 Topeka, Kansas, 66614-2374
 8625 College Boulevard, Suite 102
 Overland Park, Kansas 66210
 Telephone: (785) 233-3332
 Email: lsand@lsand.com
 LSA PROJECT NO. 2405005



1 LOWER LEVEL CEILING PLAN
 DEMOLITION
 1/8" = 1'-0"



SHEET CONTENTS:
 ● LOWER LEVEL CEILING
 PLAN - DEMOLITION

HTK PROJECT NUMBER:
 ● 2312.03

SHEET NUMBER:
ME104

ORIGINAL CONTRACT DOCUMENTS

MABEE LIBRARY RENOVATION

Washburn University
 1800 SW 19th Street, Topeka, KS 66621

DATE:
 ● July 15, 2024

REVISED DATE:
 ●
 ●
 ●



7/16/2024

7/16/2024 11:53:13 AM Autodesk Docs://Mabee Library R23 - LSA MEP/Mabee Library MEP R23.rvt

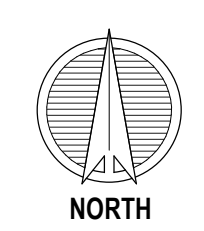
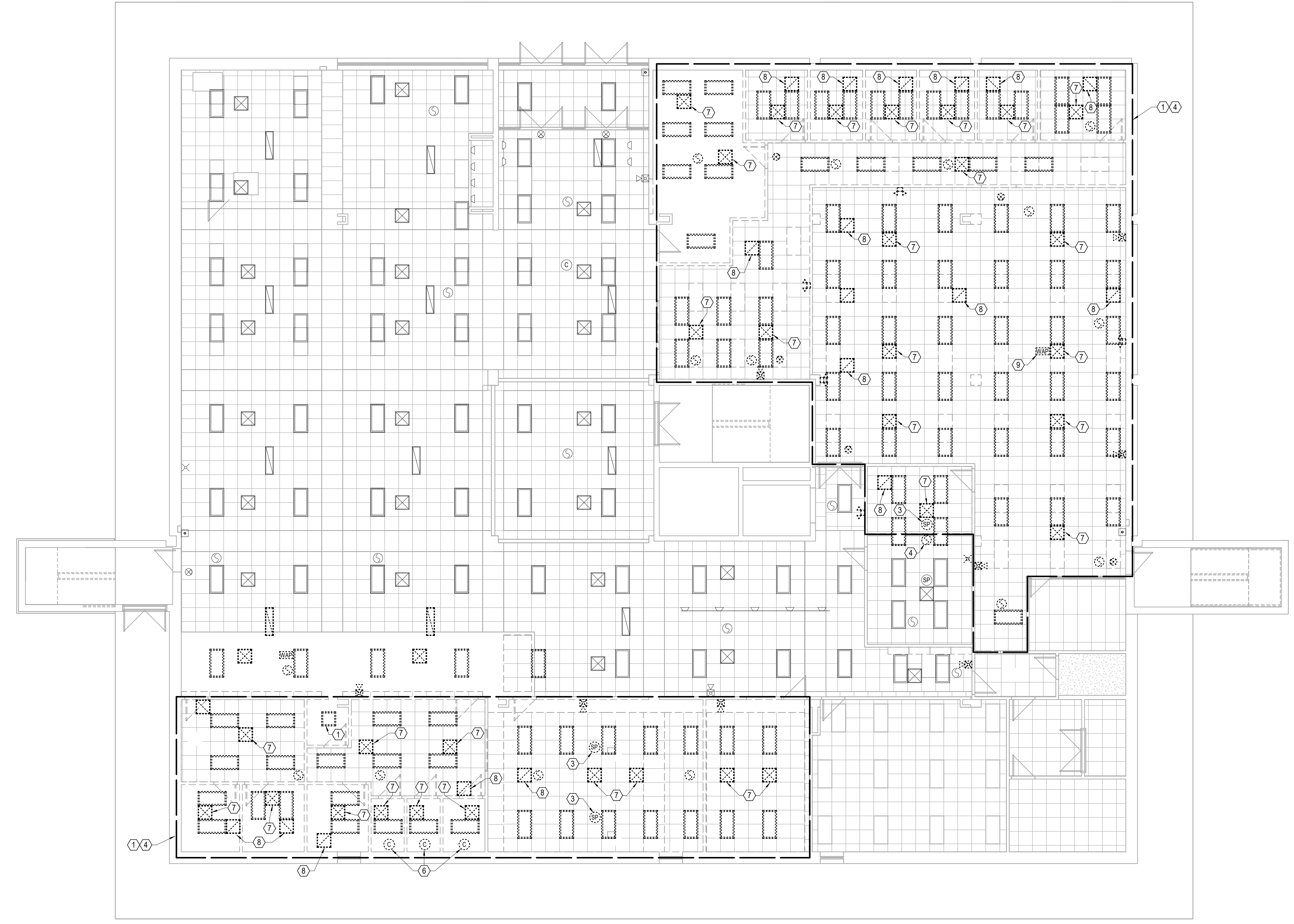

1 MAIN LEVEL CEILING PLAN
DEMOLITION
1/8" = 1'-0"



SHEET CONTENTS:
• MAIN LEVEL CEILING PLAN
• - DEMOLITION

HTK PROJECT NUMBER:
• 2312.03

SHEET NUMBER:
ME105

ORIGINAL CONTRACT DOCUMENTS

MABEE LIBRARY RENOVATION

Washburn University
1800 SW 19th Street, Topeka, KS 66621

DATE:
• July 15, 2024
REVISED DATE:
•
•
•



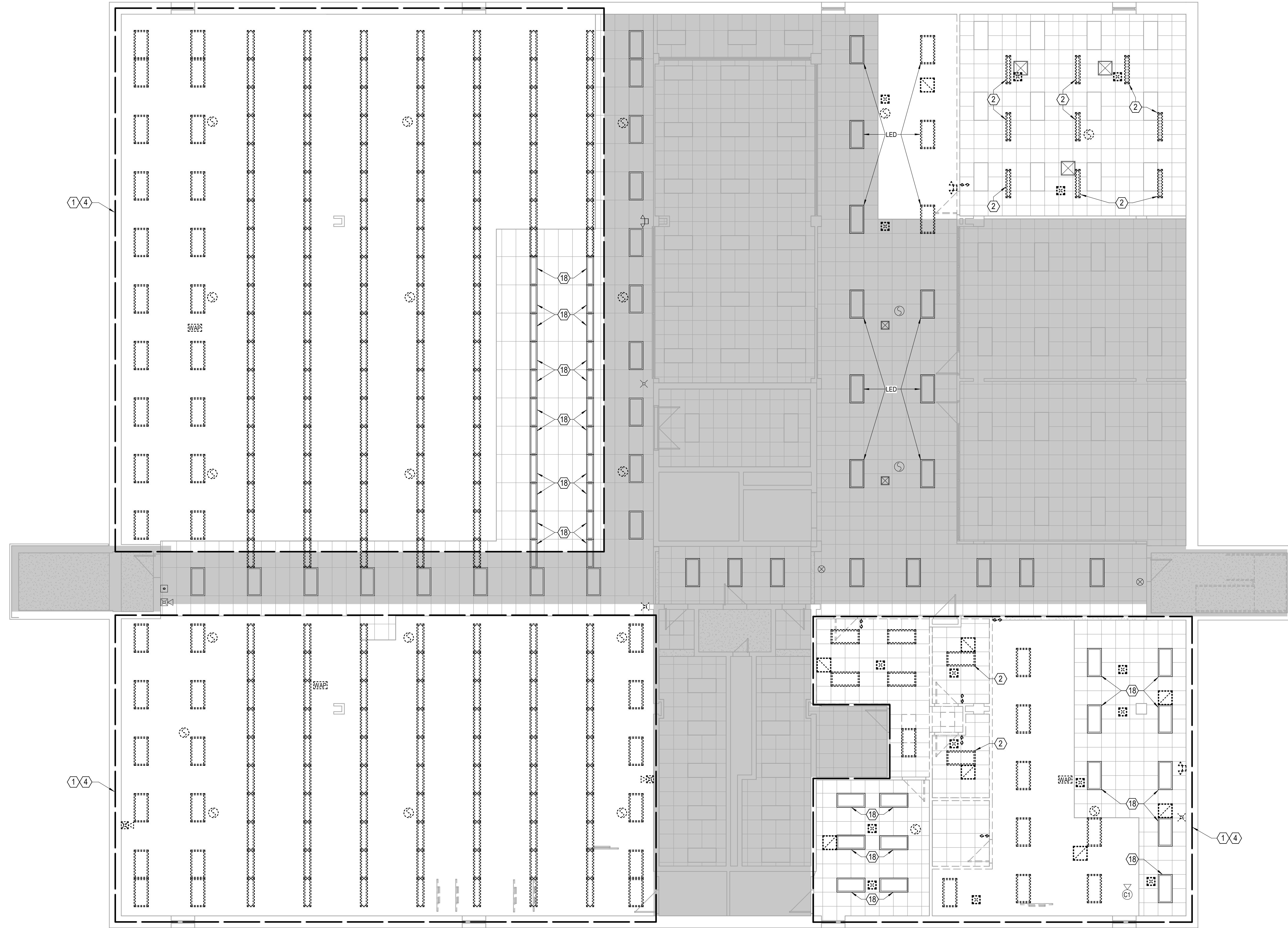

1 UPPER LEVEL CEILING PLAN
DEMOLITION
1/8" = 1'-0"



SHEET CONTENTS:
• UPPER LEVEL CEILING
• PLAN - DEMOLITION

HTK PROJECT NUMBER:
• 2312.03

SHEET NUMBER:
ME106

ORIGINAL CONTRACT DOCUMENTS

MABEE LIBRARY RENOVATION

Washburn University
1800 SW 19th Street, Topeka, KS 66621

DATE:
• July 15, 2024

REVISED DATE:
•
•
•



7/16/2024

7/16/2024 11:53:14 AM Autodesk Docs://Mabee Library R23 - LSA MEP/Mabee Library MEP R23.rvt

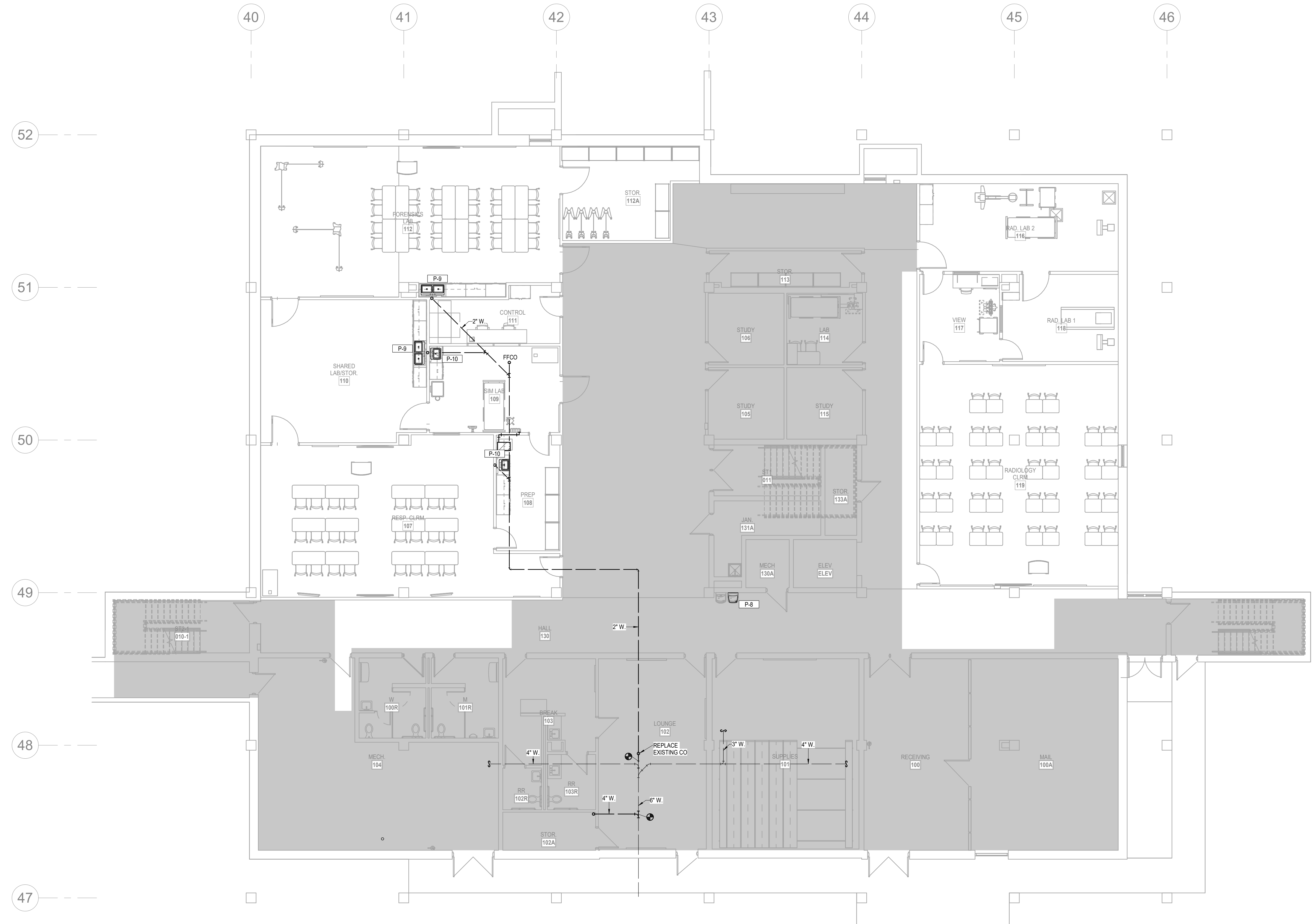

1 LOWER LEVEL FLOOR PLAN
 BELOW GRADE PLUMBING
 1/8" = 1'-0"



DATE:
 • July 15, 2024
 REVISED DATE:
 •
 •
 •

MABEE LIBRARY RENOVATION

Washburn University
 1800 SW 19th Street, Topeka, KS 66621



SHEET CONTENTS:
 • LOWER LEVEL FLOOR
 • PLAN - BELOW GRADE
 • PLUMBING

HTK PROJECT NUMBER:
 • 2312.03

SHEET NUMBER:
P100

ORIGINAL CONTRACT DOCUMENTS

7/16/2024 11:53:15 AM Autodesk Docs://Mabee Library R23 - LSA MEP/Mabee Library MEP R23.rvt

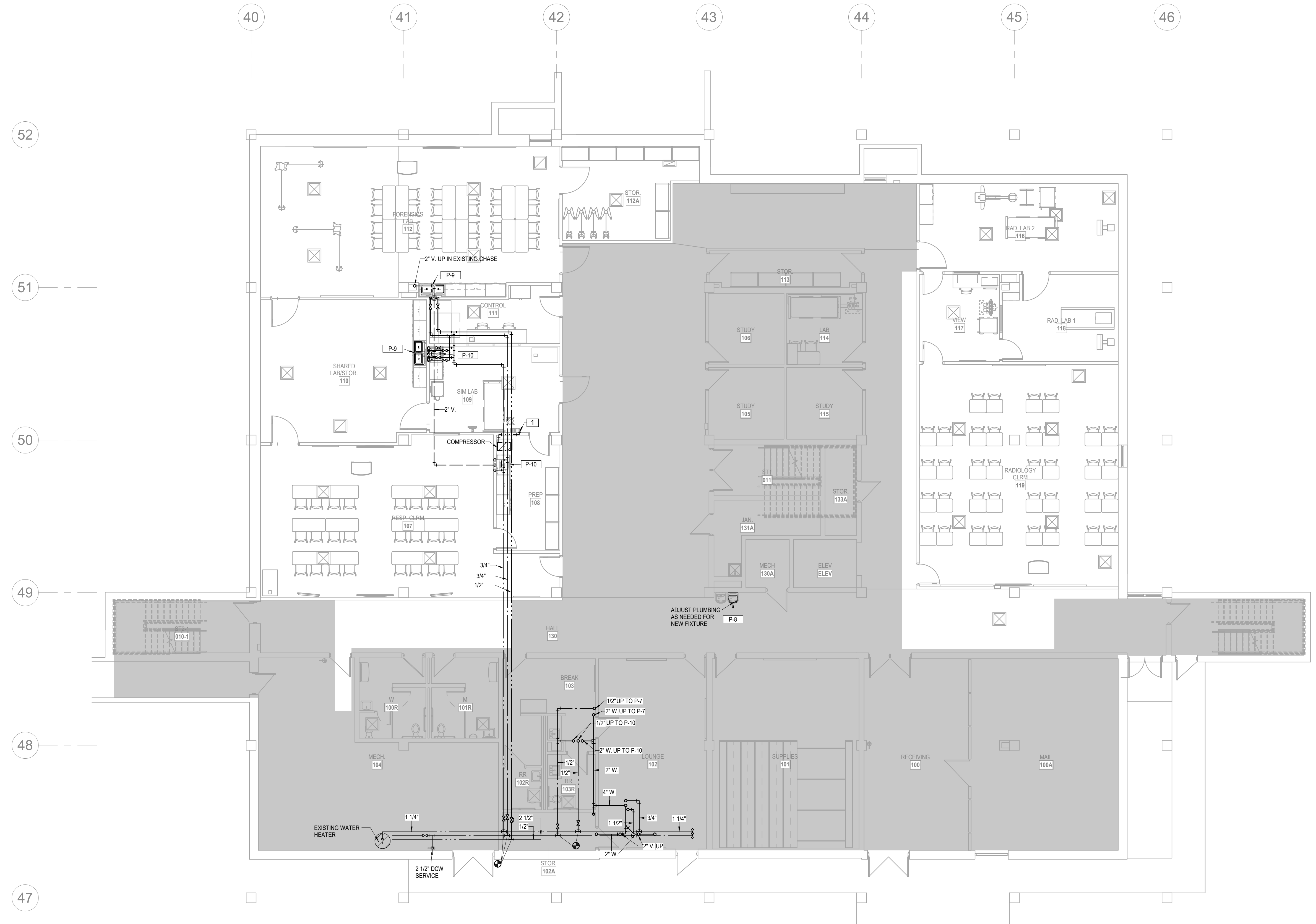

LEGEND:
1 1/2" COMPRESSED AIR FROM HEADWALL UNIT TO COMPRESSOR. FIELD VERIFY CONNECTION WITH BOTH ENDS. HEADWALL UNIT AND COMPRESSOR SHALL BE PROVIDED BY OWNER.

1 LOWER LEVEL FLOOR PLAN
PLUMBING
1/8" = 1'-0"

HTK ARCHITECTS
150 S. KANSAS AVE., SUITE 450
TOPEKA, KANSAS 66612
P. 785.266.5373 www.htkarchitects.com



7/16/2024

DATE:
• July 15, 2024
REVISED DATE:
•
•
•

MABEE LIBRARY RENOVATION

Washburn University
1800 SW 19th Street, Topeka, KS 66621

SHEET CONTENTS:
• LOWER LEVEL FLOOR PLAN - PLUMBING

HTK PROJECT NUMBER:
• 2312.03

SHEET NUMBER:
P101

ORIGINAL CONTRACT DOCUMENTS

LS&A
CONSULTING ENGINEERS
Lillian Summers & Associates P.A.
3839 SW Sumnerfield Drive, Suite A
Topeka, Kansas, 66614-2374
8625 College Boulevard, Suite 102
Overland Park, Kansas 66110
Telephone: (785) 233-3332
Email: lsand@lsand.com
LSA PROJECT NO. 2405005

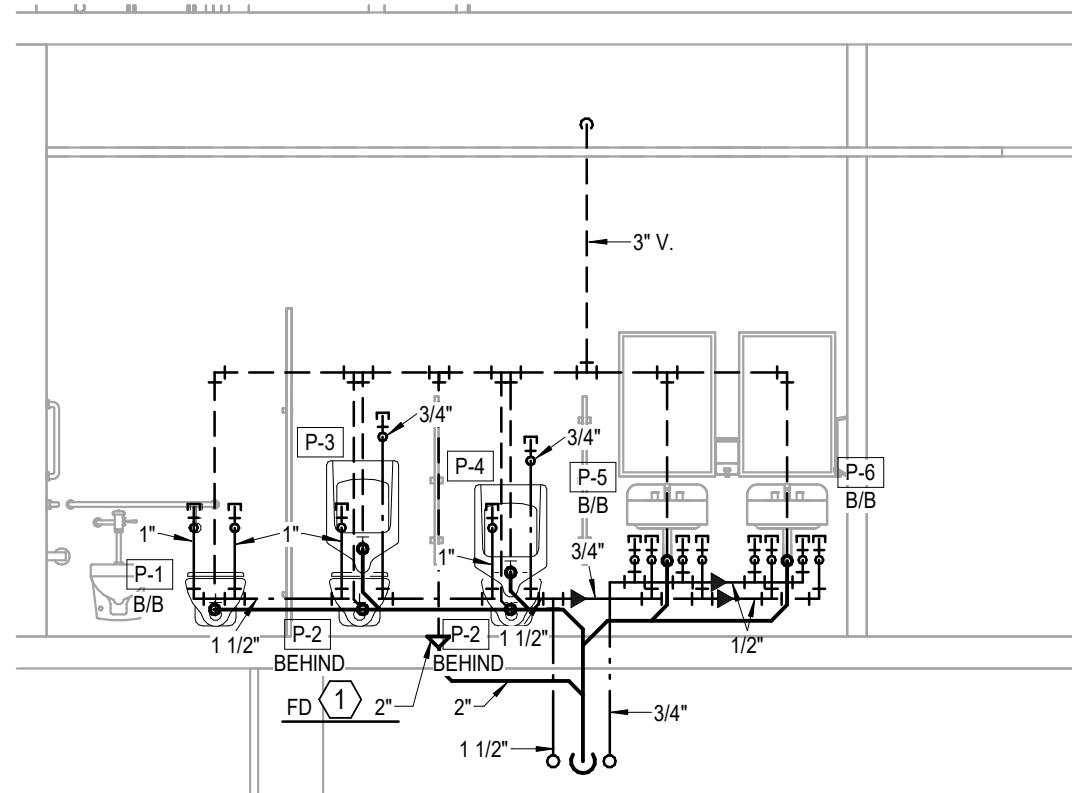

2 RESTROOM 206 - WEST ELEV.
PLUMBING
 1/4" = 1'-0"

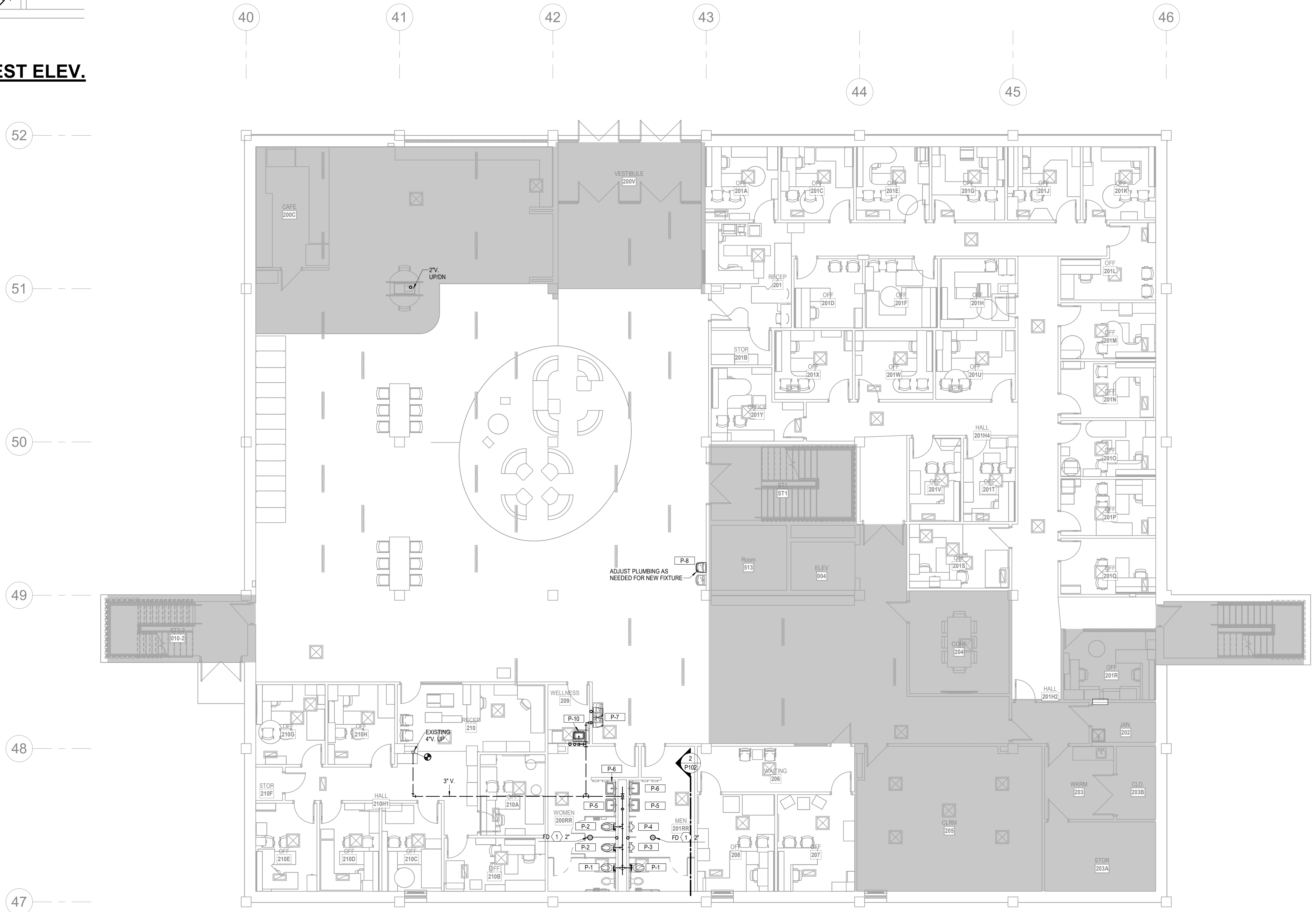

1 MAIN LEVEL FLOOR PLAN
PLUMBING
 1/8" = 1'-0"



DATE:
 • July 15, 2024
 REVISED DATE:
 •
 •
 •

SHEET CONTENTS:
 • MAIN LEVEL FLOOR PLAN
 • PLUMBING

HTK PROJECT NUMBER:
 • 2312.03

SHEET NUMBER:
P102
 ORIGINAL CONTRACT DOCUMENTS



7/16/2024 11:53:19 AM Autodesk Docs://Mabee Library R23 - LSA MEP/Mabee Library MEP R23.rvt

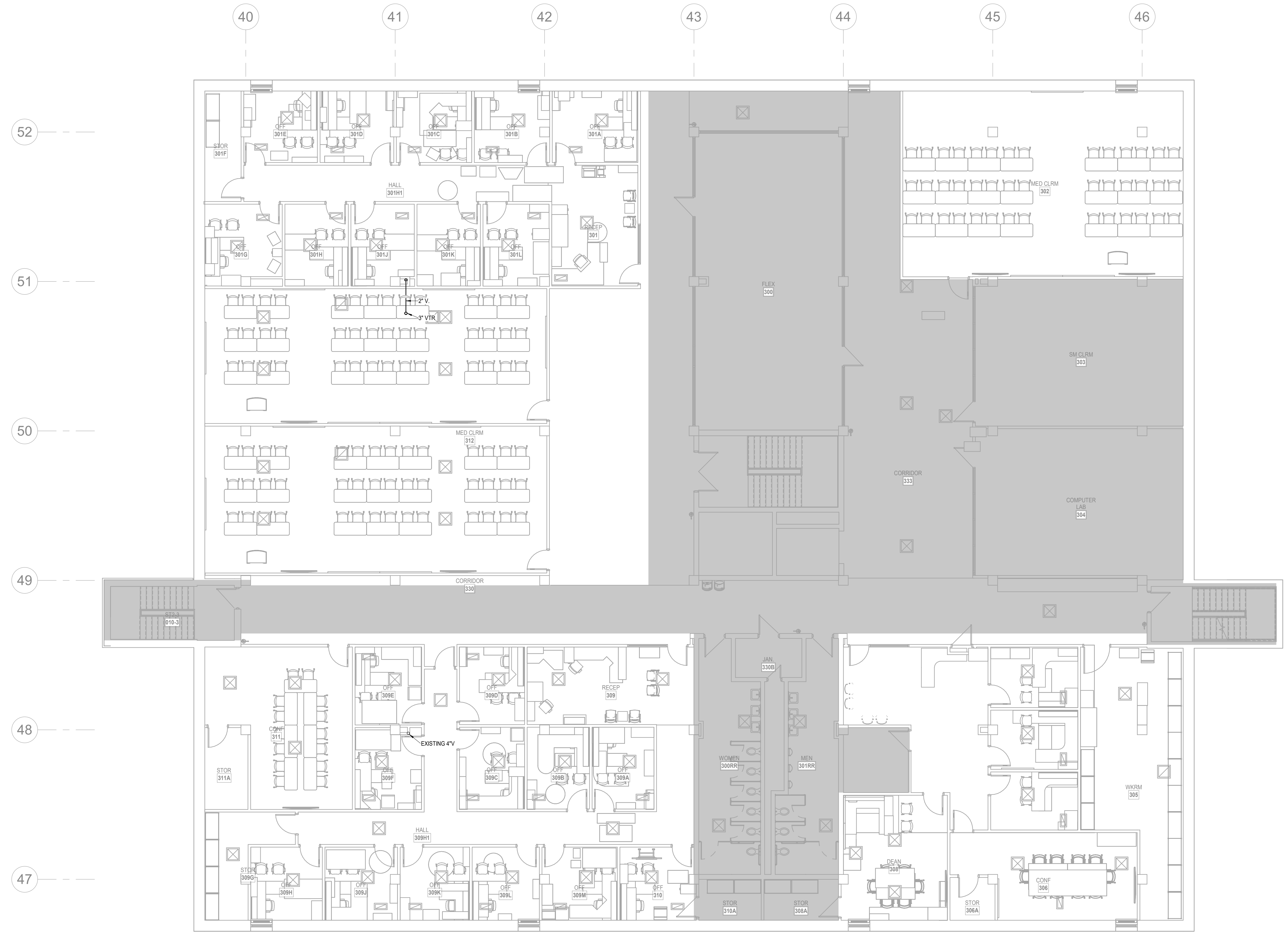

1 UPPER LEVEL FLOOR PLAN
 PLUMBING
 1/8" = 1'-0"

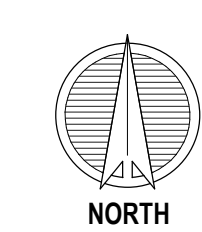

DATE:
 • July 15, 2024
 REVISED DATE:
 •
 •
 •

MABEE LIBRARY RENOVATION

Washburn University
 1800 SW 19th Street, Topeka, KS 66621



SHEET CONTENTS:
 • UPPER LEVEL FLOOR PLAN - PLUMBING

HTK PROJECT NUMBER:
 • 2312.03

SHEET NUMBER:
P103

ORIGINAL CONTRACT DOCUMENTS



7/16/2024

DATE:
 • July 15, 2024

REVISED DATE:
 •
 •
 •

MABEE LIBRARY RENOVATION

Washburn University
 1800 SW 19th Street, Topeka, KS 66621

SHEET CONTENTS:
 • LOWER LEVEL FLOOR
 PLAN - HVAC

HTK PROJECT NUMBER:
 • 2312.03

SHEET NUMBER:
M101

ORIGINAL CONTRACT DOCUMENTS

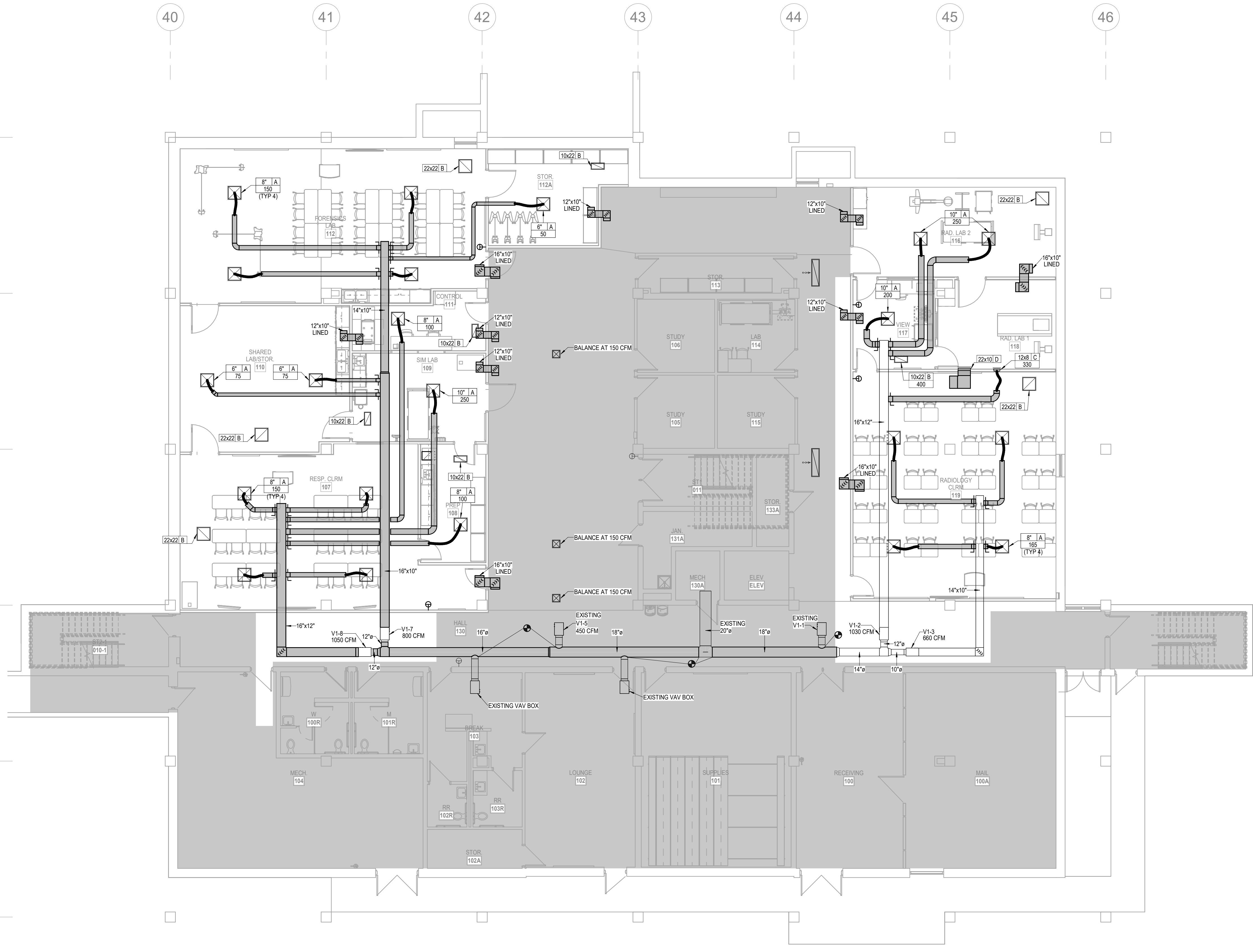

1 LOWER LEVEL FLOOR PLAN
 HVAC
 1/8" = 1'-0"

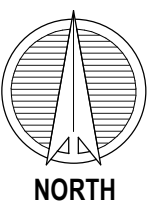

7/16/2024 11:53:21 AM Autodesk Docs://Mabee Library R23 - LSA MEP/Mabee Library MEP R23.rvt

7/16/2024 11:53:22 AM Autodesk Docs://Mabee Library R23 - LSA MEP/Mabee Library MEP R23.rvt

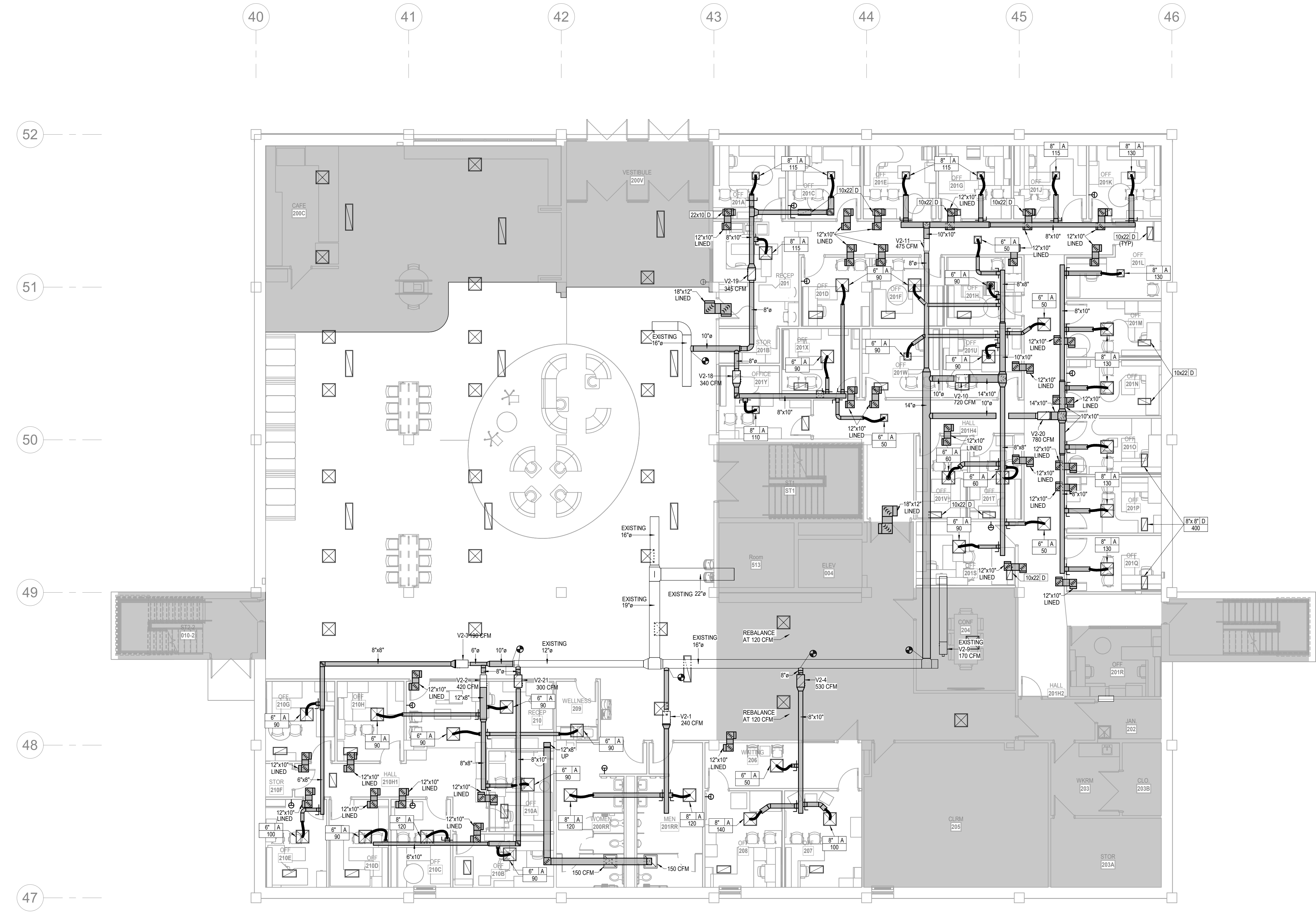

1 MAIN LEVEL FLOOR PLAN
HVAC
1/8" = 1'-0"



DATE:
● July 15, 2024
REVISED DATE:
●
●
●

MABEE LIBRARY RENOVATION

Washburn University
1800 SW 19th Street, Topeka, KS 66621



SHEET CONTENTS:
● MAIN LEVEL FLOOR PLAN
- HVAC
HTK PROJECT NUMBER:
● 2312.03
SHEET NUMBER:
M102
ORIGINAL CONTRACT DOCUMENTS

7/16/2024 11:53:25 AM Autodesk Docs://Mabee Library R23 - LSA MEP/Mabee Library MEP R23.rvt

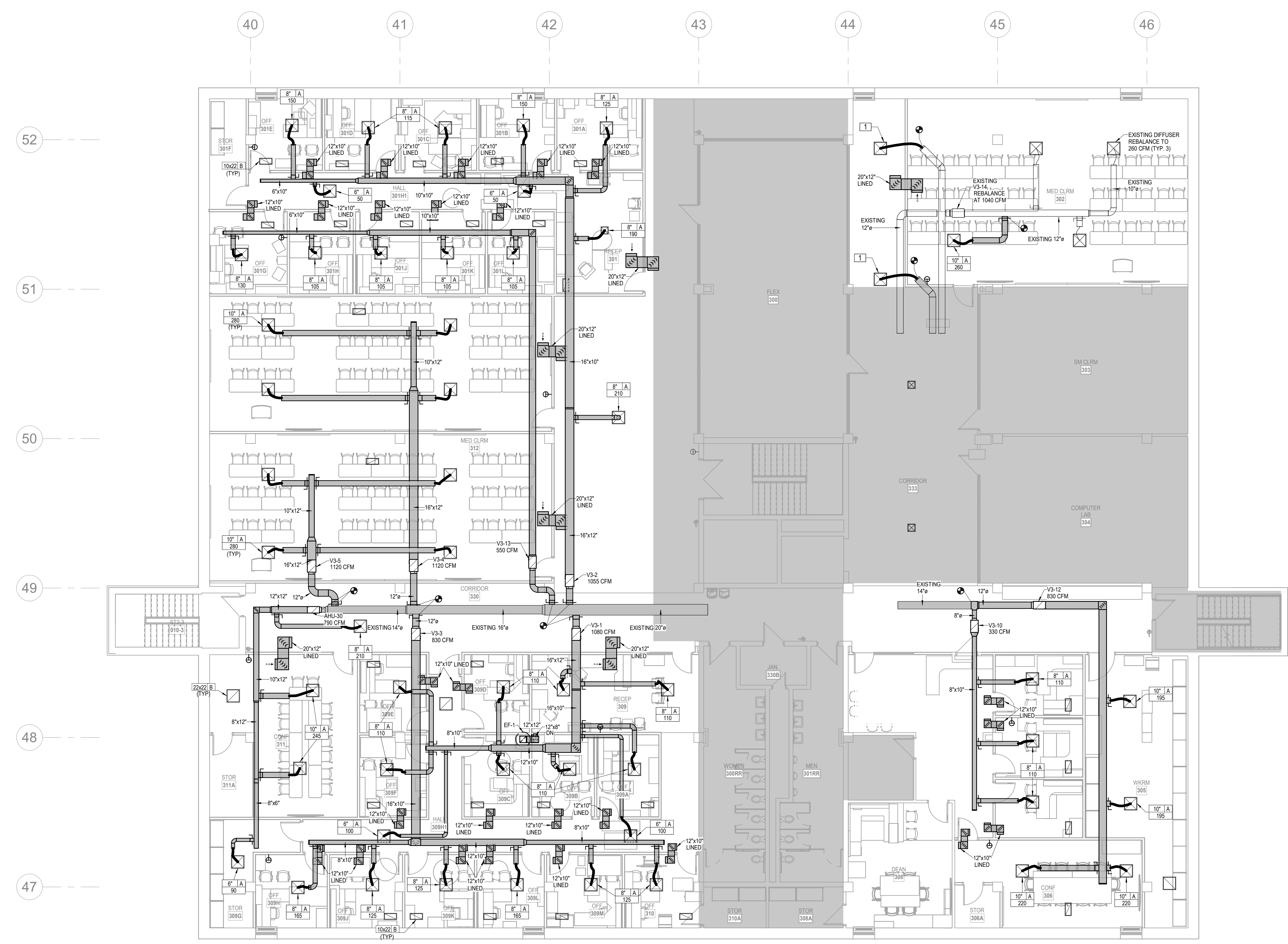

1 UPPER LEVEL FLOOR PLAN
HVAC
1/8" = 1'-0"



DATE: July 15, 2024
REVISED DATE:

MABEE LIBRARY RENOVATION
Washburn University
1800 SW 19th Street, Topeka, KS 66621



SHEET CONTENTS:
• UPPER LEVEL FLOOR PLAN - HVAC
HTK PROJECT NUMBER:
• 2312.03
SHEET NUMBER:
M103
ORIGINAL CONTRACT DOCUMENTS

7/16/2024 11:53:25 AM Autodesk Docs://Mabee Library R23 - LSA MEP/Mabee Library MEP R23.rvt

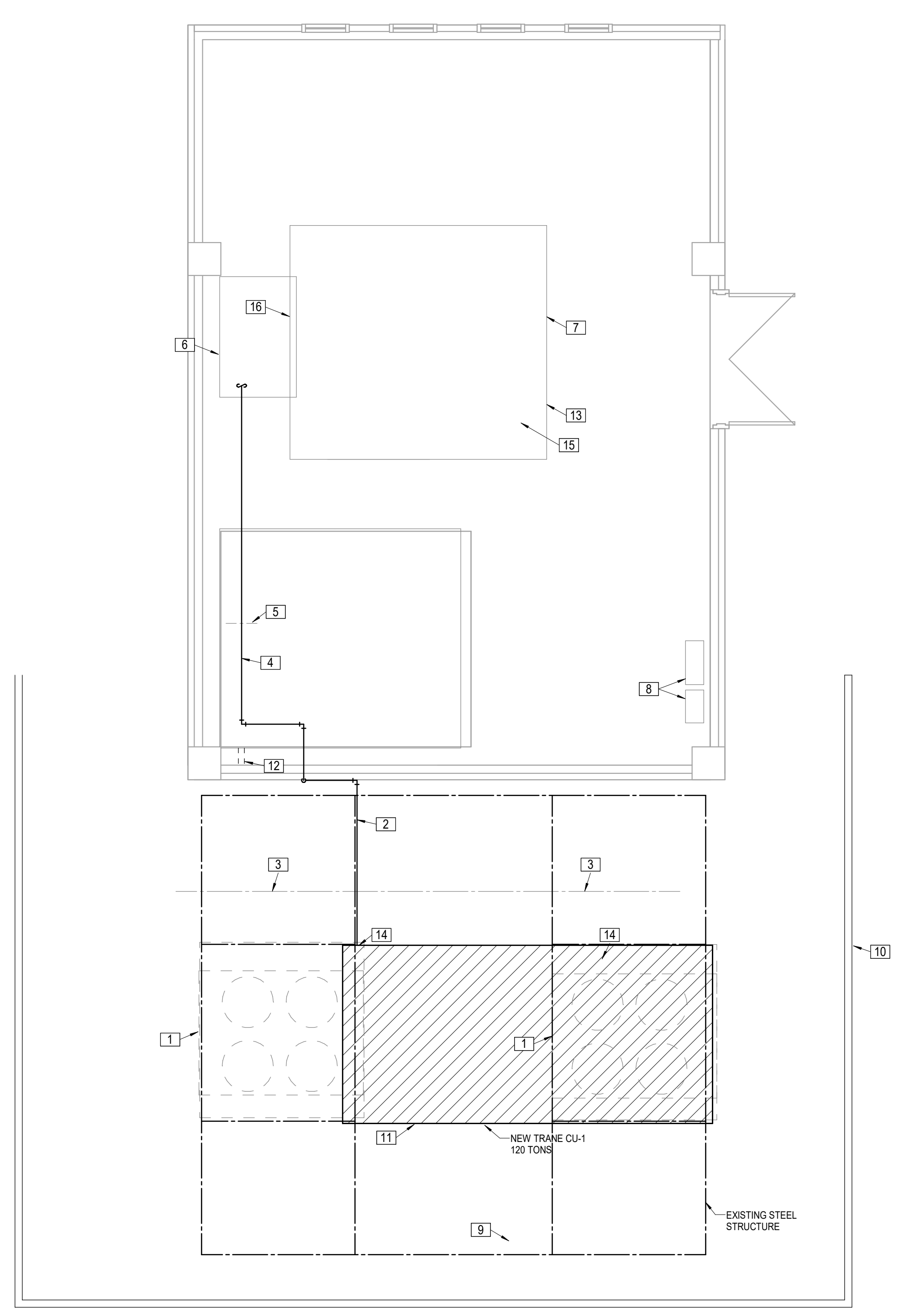

- LEGEND:**
- [1] EXISTING AIR-COOLED CONDENSING UNIT TO BE REMOVED ALONG WITH ASSOCIATED REFRIGERANT PIPING.
 - [2] INSULATED SUCTION AND EXPOSED LIQUID LINE SIZED PER MANUFACTURERS RECOMMENDATIONS. PROVIDE SUCTION WITH 1" ARMAFLEX AND ARMAFLEX INSULATION SUPPORT SLEEVE AND ARMAFLEX UV RESISTANT PIPE COVERING. ALUMINUM JACKETING AND ELBOWS ARE ALSO ACCEPTABLE.
 - [3] PROVIDE GALVANIZED STEEL STRUT OR EQUAL FOR INTERMEDIATE PIPE SUPPORT.
 - [4] STACKED LIQUID AND INSULATED SUCTION LINES. VERIFY ACCEPTABLE ROUTING WITH MANUFACTURER.
 - [5] NEW (OR REUSED IF ACCEPTABLE) PIPE SUPPORTS. FIELD VERIFY.
 - [6] REFER TO REFRIGERANT COIL PIPING DETAIL FOR NEAR-COIL PIPING AND ACCESSORIES.
 - [7] EXISTING STACKED DX COILS TO BE REPLACED WITH NEW DX COILS TO MATCH NEW CONDENSING UNIT REFRIGERANT. EXISTING COILS ARE 20"X10" COIL FACE.
 - [8] EXISTING AUTOMATIC TEMPERATURE CONTROLS.
 - [9] EXISTING STEEL SUPERSTRUCTURE SUPPORT. REFER TO STRUCTURAL DRAWING S1 FOR ALTERNATE TO PREP AND PAINT STEEL.
 - [10] EXISTING SCREEN WALL.
 - [11] UNIT CONTROL AND POWER PANELS.
 - [12] REUSE EXISTING WALL PENETRATIONS IF POSSIBLE. INSULATION SHALL PASS CONTINUOUS THROUGH PENETRATION. ENLARGE HOLES AS REQUIRED. PROVIDE FLEXIBLE SEALANT AND FLASHING.
 - [13] EXISTING VAV AHU WITH FC FAN AND INLET VANES. FAN ORIGINALLY SCHEDULED AT 20,000 PEAK CFM, 20,000 DIVERSIFIED CFM.
 - [14] PROVIDE REFRIGERANT ISOLATION VALVES AND CONNECTIONS TO UNIT AS RECOMMENDED BY MANUFACTURER.
 - [15] CLEAN EXISTING FAN BLADES AND INLET VANES.
 - [16] PROVIDE NEW P-TRAP ON EXISTING COIL OUTLET. PIPE TO FLOOR DRAIN.

- GENERAL PROJECT NOTES:**
1. CONTRACTOR SHALL VISIT SITE TO DETERMINE TOTAL SCOPE OF WORK PRIOR TO BID.
 2. FIELD VERIFY EXISTING CONDITIONS AND DIMENSIONS AS REQUIRED FOR INSTALLATION.
 3. INCLUDE ALL APPLICABLE PERMITS AND ASSOCIATED COSTS IN BID.
 4. PROPERLY DISPOSE OF ALL DEMOLITION MATERIAL OFF-SITE.
 5. THE UNIVERSITY BMS VENDOR, TRANE, SHALL PROVIDE ALL TEMPERATURE CONTROLS, ASSOCIATED POWER AND LOW VOLTAGE CONTROL WIRING. ALL COSTS SHALL BE INCLUDED IN THE CONTRACTORS BID. REFER TO GENERAL BMS NOTES.
 6. COORDINATE ALL WORK AND ANY SYSTEM SHUT-DOWNS WITH OWNER.
 7. ALL WORK SHALL BE PROVIDED FOR COMPLETE AND OPERATION SYSTEMS PER UNIVERSITY STANDARDS.
 8. CONTRACTOR AND UNIT VENDOR SHALL BE RESPONSIBLE FOR OWNER TRAINING AND CU O&M MATERIALS.
 9. TRANE TO PROVIDE ALL BMS PROGRAMMING.

CONDENSING UNIT SCHEDULE												
MARK	MANUFACTURER	MODEL NUMBER	GROSS CAPACITY (MBH)	REFRIGERANT LINE SIZING		MIN. CKT. AMPS	MAX. FUSE	MIN. IPLV	MIN. EER	MAX. dBA	ELECTRICAL CHARACTERISTICS	REMARKS
				SUCTION	LIQUID							
CU-1	TRANE	RAUJD124	1594	2 5/8	1 1/8	256	300	-	11.3	-	480V, 3PH.	1, 2, 3

- REMARKS:**
1. VERIFY EXACT LINE SIZES WITH MANUFACTURER. ROUTING AND INSTALLATION SHALL BE PER MANUFACTURER'S GUIDELINES FOR SPECIFIC FIELD CONDITIONS AND APPLICATION.
 2. CAPACITY INDICATED BASED ON AMBIENT AIR TEMPERATURE OF 100° AND SATURATED REFRIGERANT TEMPERATURE ENTERING COMPRESSOR OF 45°.
 3. PROVIDE THE FOLLOWING ACCESSORIES/FEATURES:
 - HAIL GUARDS (TO BE FIELD INSTALLED BY MECHANICAL CONTRACTOR)
 - FACTORY FURNISHED BASE MOUNT CHANNEL SUPPORTS AND SPRING ISOLATORS.
 - THERMOSTATIC EXPANSION VALVES
 - SITE GLASSES
 - FILTER/DRYERS
 - LIQUID LINE SOLENOID VALVES
 - SINGLE REFRIGERANT CIRCUIT (DUAL CIRCUITS ACCEPTABLE IF SINGLE CIRCUITS NOT PROVIDED BY EQUIVALENT APPROVED MANUFACTURERS.)
 - ACCUMULATORS
 - VAV CONTROLS FOR CONNECTION OF UNIT TO EXISTING VAV DX AHU: CARRIER MODEL 38ED48
 - VAV ELECTRICAL UNLOADERS TO ACCEPT CONTACT CLOSURE FOR CAPACITY MODULATION.
 - MIN. (4) STEPS OF CAPACITY UNLOADING

1 PENTHOUSE PLAN
HVAC
1/4" = 1'-0"

NEW DX COOLING COIL												
TYPE	DIVERSIFIED CFM	ENT. AIR		LVG. AIR		CAPACITY - BTU/HR			MIN. FACE AREA	MIN. NO. ROWS	APD I.W.C.	REMARKS
		D.B.	W.B.	D.B.	W.B.	SENSIBLE	LATENT	TOTAL				
DIRECT EXPANSION - ROW SPLIT-CIRCUITED TO BALANCE LOAD ON CONDENSING UNITS	20,800	91.0°F	72.0°F	55.0°F	54.5°F	810,000	400,000	1,210,000	48 SQ. FT.	6	1.0	1, 2

- REMARKS:**
1. ALL COIL DATA BASED ON ORIGINAL SCHEDULED VALUES.
 2. FIELD VERIFY ACTUAL AREA, ROWS, ETC. ACTUAL INSTALLED SHALL SUPERSEDE SCHEDULED VALUES.

LS&A
LITTLE, SUMMERS & ASSOCIATES P.A.
CONSULTING ENGINEERS
3839 SW Sumnerfield Drive, Suite A
Topeka, Kansas, 66614-2374
8625 College Boulevard, Suite 102
Overland Park, Kansas 66210
Telephone: (785) 233-3332
Email: lsand@lsand.com
LSA PROJECT NO. 2405005

HTK ARCHITECTS
658 N. 15TH ST. STE. 400
TOPEKA, KANSAS 66612
P. 785.266.5373 www.htkarchitects.com



DATE:
• July 15, 2024

REVISED DATE:
•
•
•

MABEE LIBRARY RENOVATION
Washburn University
1800 SW 19th Street, Topeka, KS 66621

SHEET CONTENTS:
• PENTHOUSE FLOOR PLAN
• HVAC

HTK PROJECT NUMBER:
• 2312.03

SHEET NUMBER:
M104

ORIGINAL CONTRACT DOCUMENTS

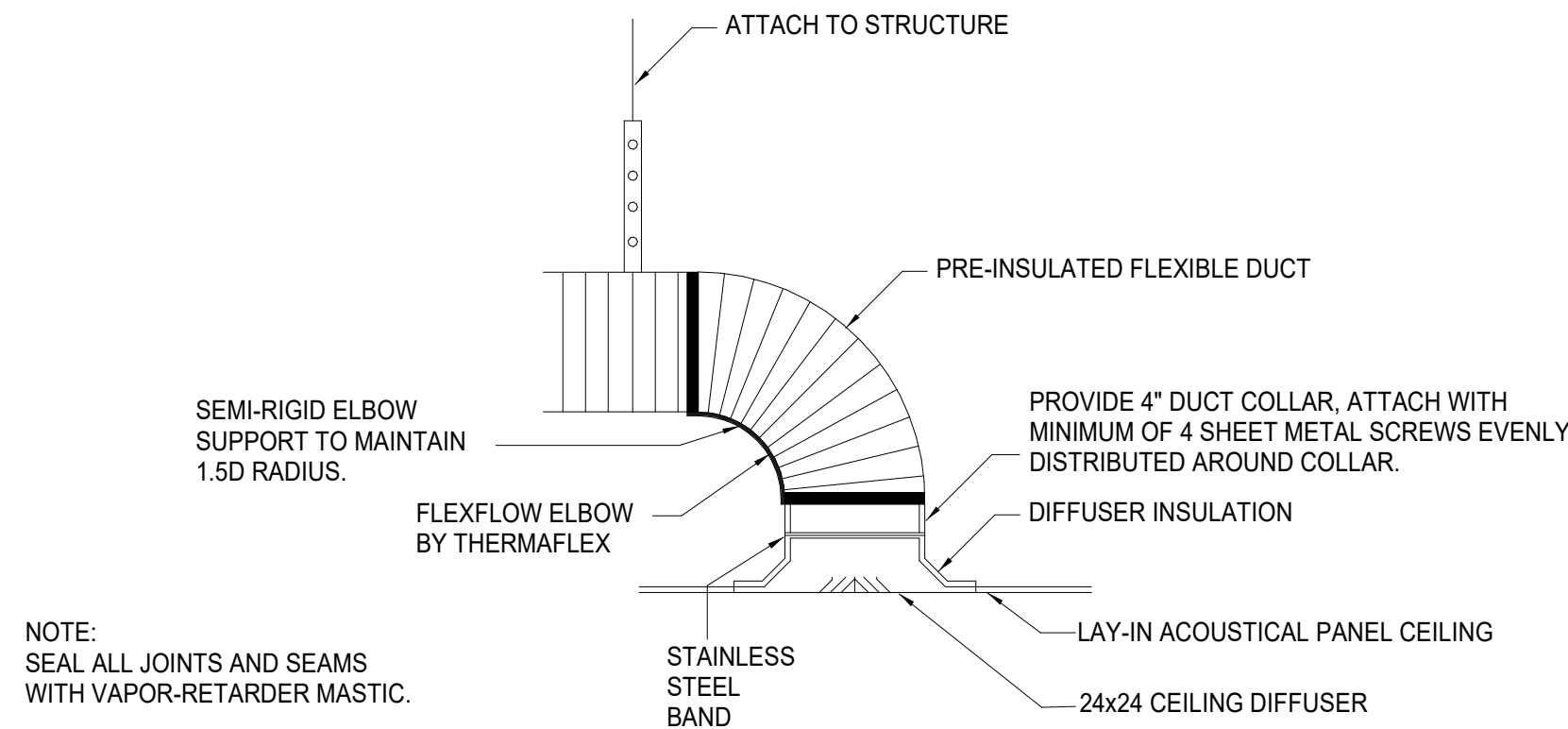

1 SUPPLY DIFFUSER CONNECTION LAY-IN CEILING, COLLAR
NOT TO SCALE

NOTES:
1. CONTRACTOR SHALL PROVIDE SECTION OF RIGID INSULATION BETWEEN SADDLE SUPPORT AND PIPE AS REQUIRED TO PREVENT DAMAGE TO INSULATION. HANGER SHALL NOT BE ON THE INTERIOR OF THE INSULATION.

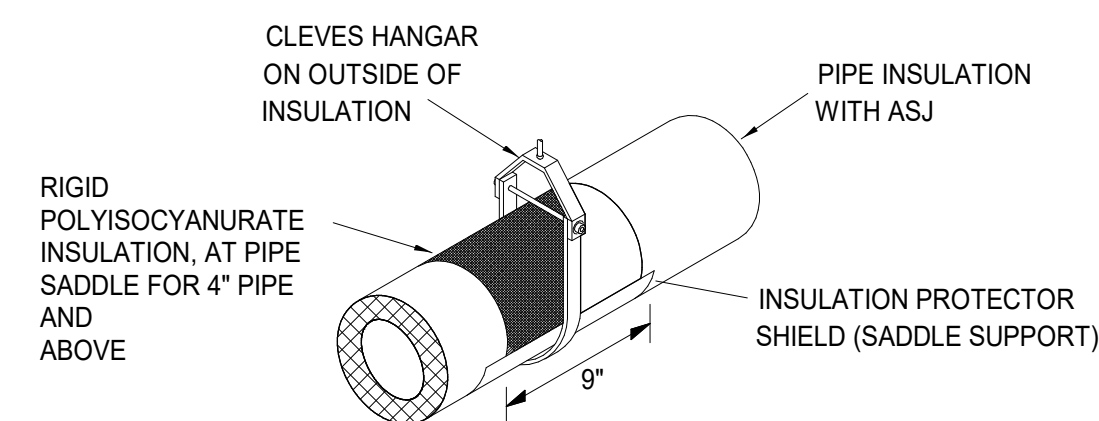

2 PIPE SUPPORT DETAIL
NOT TO SCALE

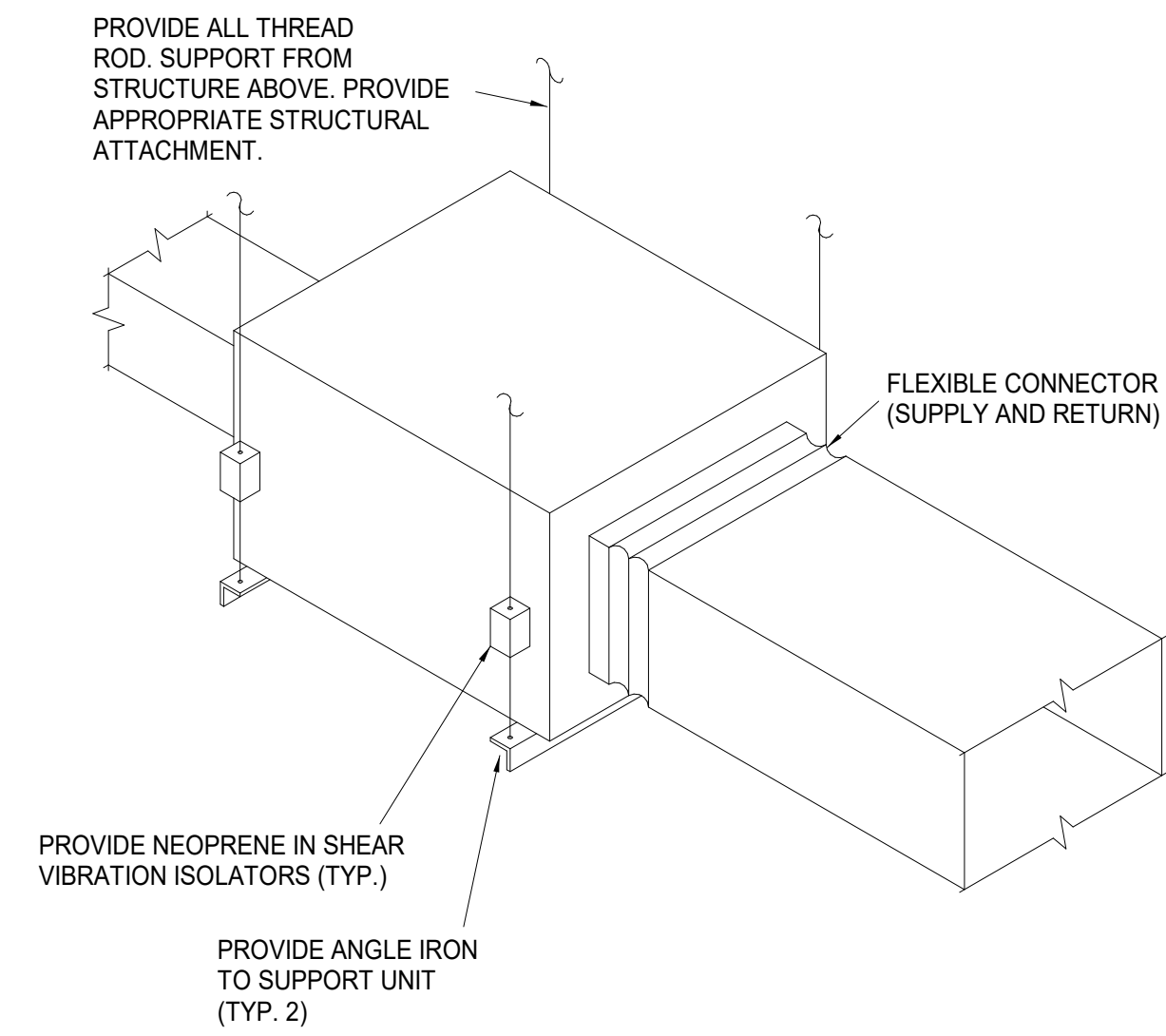

(TYPICAL FOR ALL EQUIPMENT SUPPORTED FROM STRUCTURE)

3 VIBRATION ISOLATION DETAIL
NOT TO SCALE

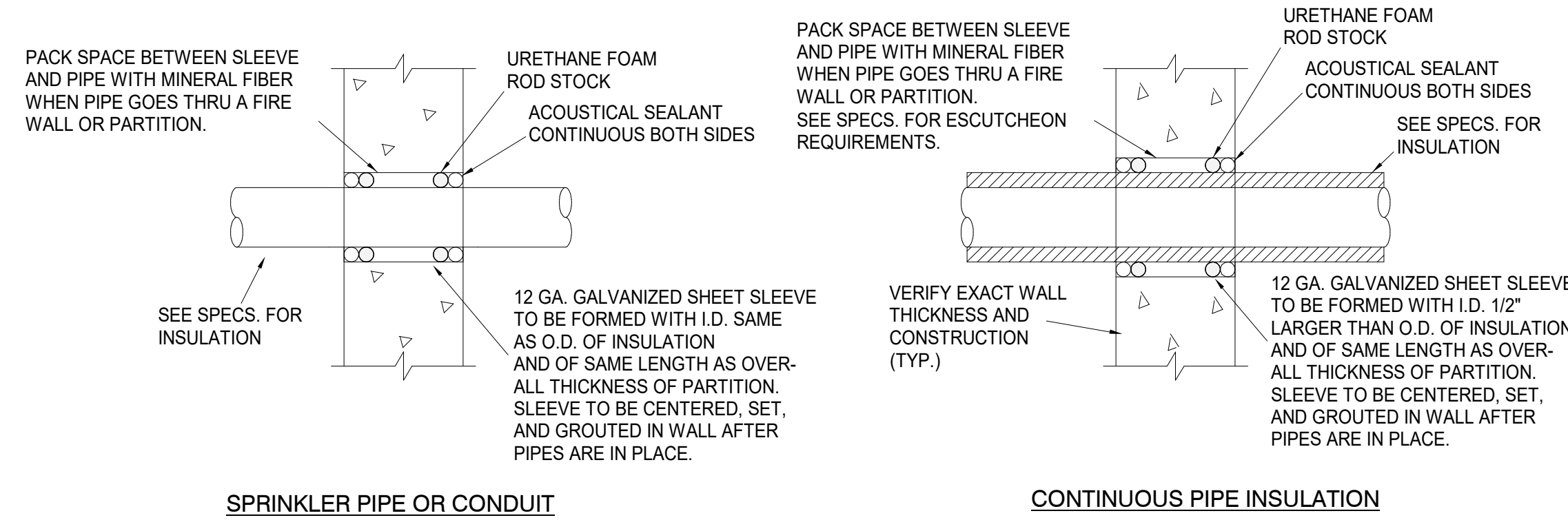

4 WALL SLEEVE DETAIL
NO SCALE

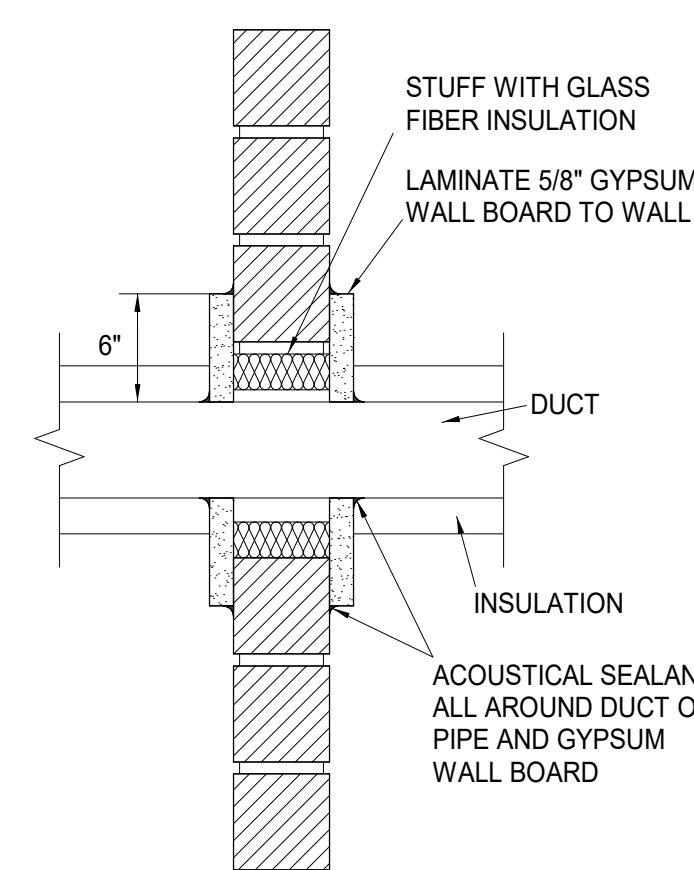

5 DUCT PENETRATION DETAIL
NO SCALE



7/16/2024

DATE:
• July 15, 2024

REVISED DATE:
•
•
•

SHEET CONTENTS:
• MECHANICAL DETAILS

HTK PROJECT NUMBER:
• 2312.03

SHEET NUMBER:
MP101

ORIGINAL CONTRACT DOCUMENTS

VAV TERMINAL UNIT SCHEDULE															
MARK	MANUFACTURER	BOX TYPE	MODEL NUMBER	MAX CFM	COOLING CFM	MINIMUM CLG. CFM	HEATING CFM	ELECTRIC REHEAT COIL				ELECTRICAL CHARACTERISTICS	INLET SIZE	# COIL ROWS	REMARKS
								EAT	MIN. LAT	INLET SP	MAX. APD				
FIRST FLOOR	V1-2	PRICE	SC W/ ELEC RH	SDV5	1030		310	4	55	90	1.0	0.5	277V.		
	V1-3	PRICE	SC W/ ELEC RH	SDV5	660		200	2.5	55	90	1.0	0.5	277V.		
	V1-7	PRICE	SC W/ ELEC RH	SDV5	800		250	3.5	55	90	1.0	0.5	277V.		
	V1-8	PRICE	SC W/ ELEC RH	SDV5	1050		315	4	55	90	1.0	0.5	277V.		
SECOND FLOOR	V2-1	PRICE	SC W/ ELEC RH	SDV5	240		105	1.5	55	90	1.0	0.5	277V.		
	V2-2	PRICE	SC W/ ELEC RH	SDV5	420		140	2	55	90	1.0	0.5	277V.		
	V2-3	PRICE	SC W/ ELEC RH	SDV5	190		95	1	55	90	1.0	0.5	277V.		
	V2-4	PRICE	SC W/ ELEC RH	SDV5	290		140	2	55	90	1.0	0.5	277V.		
	V2-10	PRICE	SC W/ ELEC RH	SDV5	720		215	3	55	90	1.0	0.5	277V.		
	V2-11	PRICE	SC W/ ELEC RH	SDV5	475		145	2	55	90	1.0	0.5	277V.		
	V2-18	PRICE	SC W/ ELEC RH	SDV5	290		140	2	55	90	1.0	0.5	277V.		
	V2-19	PRICE	SC W/ ELEC RH	SDV5	345		170	2	55	90	1.0	0.5	277V.		
	V2-20	PRICE	SC W/ ELEC RH	SDV5	780		235	3	55	90	1.0	0.5	277V.		
	V2-21	PRICE	SC W/ ELEC RH	SDV5	300		150	2	55	90	1.0	0.5	277V.		
THIRD FLOOR	V3-1	PRICE	SC W/ ELEC RH	SDV5	1080		315	4	55	90	1.0	0.5	277V.		
	V3-2	PRICE	SC W/ ELEC RH	SDV5	1055		315	4	55	90	1.0	0.5	277V.		
	V3-3	PRICE	SC W/ ELEC RH	SDV5	830		240	3	55	90	1.0	0.5	277V.		
	V3-4	PRICE	SC W/ ELEC RH	SDV5	1120		340	4	55	90	1.0	0.5	277V.		
	V3-5	PRICE	SC W/ ELEC RH	SDV5	1120		340	4	55	90	1.0	0.5	277V.		
	V3-6	PRICE	SC W/ ELEC RH	SDV5	790		235	3	55	90	1.0	0.5	277V.		
	V3-10	PRICE	SC W/ ELEC RH	SDV5	330		170	2	55	90	1.0	0.5	277V.		
	V3-12	PRICE	SC W/ ELEC RH	SDV5	830		240	3	55	90	1.0	0.5	277V.		
V3-18	PRICE	SC W/ ELEC RH	SDV5	550		165	2	55	90	1.0	0.5	277V.			

- NOTES:
- CAPACITIES BASED ON PRIMARY AIR=55°F
 - VAV BOX SUBMITTALS SHALL INCLUDE COIL CAPACITIES, COIL APD AT MAXIMUM COOLING CFM, AND HEATING AIR DISCHARGE TEMPERATURE AT LISTED CFM. DISCHARGE AND RADIATED SOUND POWER BY OCTAVE, SOUND NC AT 1" INLET PRESSURE.
 - BOX HEIGHT SHALL NOT EXCEED 8" FOR SIZE 4, 5, 6; 10" FOR SIZE 7, 8; 12-1/2" FOR SIZE 9, 10; 15" FOR SIZE 12; 17-1/2" FOR SIZE 16.
 - PROVIDE FIBER-FREE ACOUSTICAL LINER.

GRILLES, REGISTERS AND DIFFUSERS SCHEDULE									
MARK	MANUFACTURER	MODEL NUMBER	APPLICATION			FINISH	FRAME TYPE	DAMPER	REMARKS
			SUP.	RET.	EXH.				
(A)	PRICE	ASPD	X			WHITE	T-BAR	NO	1, 2, 3, 5
(B)	PRICE	635		X	X	WHITE	T-BAR	NO	2, 4, 5
(C)	PRICE	610	X			WHITE	FLANGE	NO	2, 6
(D)	PRICE	635		X	X	WHITE	FLANGE	NO	6

- REMARKS:
- 24x24 MODULE
 - ALUMINUM CONSTRUCTION
 - PROVIDE INSULATED BACK PANEL
 - PROVIDE SQUARE-TO-ROUND SHOWN ON PLANS
 - PROVIDE WITH FLANGE
 - EXHIBIT DUCT ELBOW SUPPORT AT ALL ROUND DUCT DROPS AND SR2 2" SPACER WHERE ROUND DUCT CONNECTION
 - MRI COMPLIANT

PIPE SIZES FOR INDIVIDUAL PLUMBING FIXTURES					
MARK	DESCRIPTION	WASTE	VENT	DCW	DHW
P-1	ADA COMPLIANT WATER CLOSET	4"	2"	1 1/4"	-
P-2	WATER CLOSET	4"	2"	1 1/4"	-
P-3	URINAL	2"	2"	1"	-
P-4	ADA URINAL	2"	2"	1"	-
P-5	ADA LAVATORY	2"	2"	1/2"	1/2"
P-6	LAVATORY	2"	2"	1/2"	1/2"
P-7	DUAL HEIGHT DRINK FOUNTAIN	2"	2"	1/2"	-
P-8	ADA DRINK FOUNTAIN	2"	2"	1/2"	-
P-9	DOUBLE COMPARTMENT SS SINK	2"	2"	1/2"	1/2"
P-10	SINGLE COMPARTMENT SS SINK	2"	2"	1/2"	1/2"

EXHAUST FAN SCHEDULE							
MARK	MANUFACTURER	MODEL NUMBER	CFM	S.P.	HP	VOLTAGE/PHASE	CONTROL
EF-1	GREENHECK	G-080	300	0.375	FRAC.	120V./1PH.	DOC.

PLUMBING FIXTURE SCHEDULE						
MARK	MANUFACTURER/ MODEL	DESCRIPTION	MANUFACTURER/ MODEL	FITTINGS		REMARKS
				DESCRIPTION		
P-1	TOTO CT708U	ADA COMPLIANT WATER CLOSET; WHITE VITREOUS CHINA, ELONGATED BOWL, WALL MOUNTED, FLUSH VALVE BOWL WITH TOP SPUD AND FLAT BOLT COVERS. 1.6 GALLON SIPHON JET FLUSHING ACTION.	TOTO TET1GB	MANUAL, QUIET, DIAPHRAM FLUSHOMETER FOR EXPOSED WATER CLOSET INSTALLATION, CHROME PLATED, DECORATIVE HANDLE CAP, 1 1/2" I.P.S. SCREWDRIVER BAK-CHEK ANGLE STOP WITH VACUUM BREAKER FLUSH CONNECTION, AND SPUD COUPLING FOR 1 1/2" TOP SPUD. PROVIDE WITH WALL AND SPUD FLANGES. 1.6 GALLON. PROVIDE WITH OVERRIDE COVER.		4, 7
	BEMIS 1955CT	SEAT: SOLID PLASTIC OPEN FRONT, WHITE FOR AN ELONGATED BOWL, INTEGRAL BUMBERS, EXTERNAL CHECK HINGES WITH STAINLESS STEEL POSTS.				
P-2	TOTO CT708U	WATER CLOSET; WHITE VITREOUS CHINA, ELONGATED BOWL, WALL MOUNTED, FLUSH VALVE BOWL WITH TOP SPUD AND FLAT BOLT COVERS. 1.6 GALLON SIPHON JET FLUSHING ACTION.	TOTO TET1GB	MANUAL, QUIET, DIAPHRAM FLUSHOMETER FOR EXPOSED WATER CLOSET INSTALLATION, CHROME PLATED, DECORATIVE HANDLE CAP, 1 1/2" I.P.S. SCREWDRIVER BAK-CHEK ANGLE STOP WITH VACUUM BREAKER FLUSH CONNECTION, AND SPUD COUPLING FOR 1 1/2" TOP SPUD. PROVIDE WITH WALL AND SPUD FLANGES. 1.6 GALLON. PROVIDE WITH OVERRIDE COVER.		7
	BEMIS 1955CT	SEAT: SOLID PLASTIC OPEN FRONT, WHITE FOR AN ELONGATED BOWL, INTEGRAL BUMBERS, EXTERNAL CHECK HINGES WITH STAINLESS STEEL POSTS.				
P-3	ZURN 2572-U	URINAL; WHITE VITREOUS CHINA WALL HUNG URINAL WITH 3/4" TOP SPUD, 1.0 GALLON SIPHON JET FLUSHING ACTION. MOUNT FIXTURE RIM AT 24" AFF.	TOTO TEU1GA	MANUAL, QUIET, DIAPHRAM FLUSHOMETER FOR EXPOSED URINAL INSTALLATION, CHROME PLATED, DECORATIVE HANDLE CAP, 3/4" I.P.S. SCREWDRIVER BAK-CHEK ANGLE STOP WITH VACUUM BREAKER FLUSH CONNECTION, AND SPUD FLANGES. 1.0 GALLON PER FLUSH.		7, 8, 9
		PROVIDE FLOOR MOUNTED, HEAVY DUTY TUBULAR STEEL UPRIGHTS, ADJUSTABLE CARRIER PLATED HANGAR AND ALL OTHER REQUIRED MOUNTING HARDWARE.				
P-4	ZURN 2572-U	URINAL; WHITE VITREOUS CHINA WALL HUNG URINAL WITH 3/4" TOP SPUD, 1.0 GALLON SIPHON JET FLUSHING ACTION. MOUNT FIXTURE RIM AT 24" AFF.	TOTO TEU1GA	MANUAL, QUIET, DIAPHRAM FLUSHOMETER FOR EXPOSED URINAL INSTALLATION, CHROME PLATED, DECORATIVE HANDLE CAP, 3/4" I.P.S. SCREWDRIVER BAK-CHEK ANGLE STOP WITH VACUUM BREAKER FLUSH CONNECTION, AND SPUD FLANGES. 1.0 GALLON PER FLUSH.		7, 8, 9
		PROVIDE FLOOR MOUNTED, HEAVY DUTY TUBULAR STEEL UPRIGHTS, ADJUSTABLE CARRIER PLATED HANGAR AND ALL OTHER REQUIRED MOUNTING HARDWARE.				
P-5	TOTO LT307	WALL HUNG ADA, VITREOUS CHINA, COTTON COLOR WITH BACK SPLASH.	TOTO TEL105	SINGLE LEVER ADA FAUCET WITH 1/2" CONNECTIONS AND GRID DRAIN WITHOUT POP-UP HOLE. VANDAL RESISTANT 0.5 GPM SPRAY POLISHED CHROME FINISH.		1, 2, 5
P-6	TOTO LT307	WALL HUNG, VITREOUS CHINA, COTTON COLOR WITH BACK SPLASH.	TOTO TEL105	SINGLE LEVER ADA FAUCET WITH 1/2" CONNECTIONS AND GRID DRAIN WITHOUT POP-UP HOLE. VANDAL RESISTANT 0.5 GPM SPRAY POLISHED CHROME FINISH.		1, 2, 5
P-7	ELKAY EZ2L8WSLK	ADA COMPLIANT DUAL HEIGHT ELECTRIC WATER COOLER; BARRIER FREE WATER COOLER PROVIDING 8 GPM OF 50 DEGREE WATER AT 90 DEGREE AMBIENT. FRONT AND SIDE PUSHBARS, ADA COMPLIANT LEAD FREE, MOUNT WITH MIN. 27" KNEE CLEARANCE AND SPOUT AT NO MORE THAN 36" AFF. WITH BOTTLE FILLING STATION				2, 6
P-8	ELKAY LZ58L	ADA COMPLIANT ELECTRIC WATER COOLER; BARRIER FREE WATER COOLER PROVIDING 8 GPM OF 50 DEGREE WATER AT 90 DEGREE AMBIENT. FRONT AND SIDE PUSHBARS, LEAD FREE, MOUNT WITH MIN. 27" KNEE CLEARANCE AND SPOUT AT NO MORE THAN 36" AFF.				2, 6
P-9	ELKAY LRAD 2522	ADA SINGLE COMPARTMENT SINK; SEAMLESS #18 GAUGE, TYPE 302 (18-8) NICKEL BEARING STAINLESS STEEL, LK-6K-H SATIN FINISH FULLY UNDERCOATED, SINGLE HOLE, 6 1/2" BOWL DEPTH, 1 3/4" RADIUS COVED CORNERS, SELF RIMMING.	ZURN Z81284-XL	CENTERSET ADA GOOSENECK FAUCET WITH METAL LEVER HANDLES, 1/2" CONNECTIONS, WITHOUT DRAIN AND POP-UP HOLE. POLISHED CHROME FINISH. PROVIDE BASKET STRAINER AND DRAIN.		1, 2, 3
P-10	ELKAY LRAD 1720	ADA SINGLE COMPARTMENT SINK; SEAMLESS #18 GAUGE, TYPE 302 (18-8) NICKEL BEARING STAINLESS STEEL, LK-6K-H SATIN FINISH FULLY UNDERCOATED, SINGLE HOLE, 6 1/2" BOWL DEPTH, 1 3/4" RADIUS COVED CORNERS, SELF RIMMING.				2, 6

- PROVIDE LOOSE KEY STOPS AND FLEXIBLE RISERS
- INSULATED EXPOSED TAILPIECE, P-TRAPS, AND WATER RISERS
- PROVIDE CHROME PLATED BRASS TAILPIECE AND BASKET STRAINER
- PROVIDE FLUSH VALVE HANDLE ON WIDE SIDE OF STALL
- PROVIDE CHROME PLATED BRASS TAILPIECE AND GRID DRAIN
- PROVIDE CONCEALED ARM TYPE CARRIER WITH SQUARE TUBULAR STEEL UP-RIGHTS AND BLOCK TYPE BASES
- CHLORAMINE RESISTANT, DUAL FILTER BYPASS DIAPHRAGM
- CARRIER
- PROVIDE FLUSH WALL CLEANOUTS LOCATED 6" ABOVE FLUSH BOX VALVE BODY

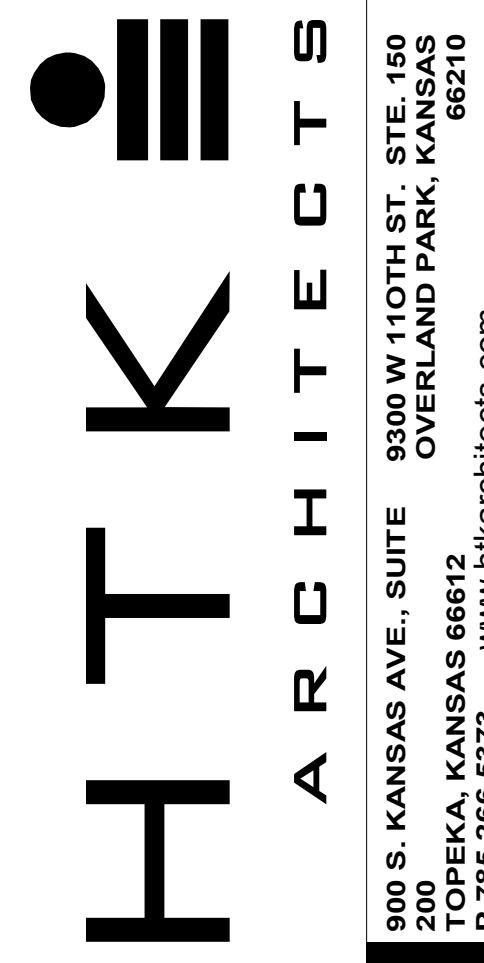

7/16/2024

DATE:
● July 15, 2024

REVISED DATE:
●
●
●

MABEE LIBRARY RENOVATION

Washburn University
1800 SW 19th Street, Topeka, KS 66621

SHEET CONTENTS:
MECHANICAL SCHEDULES

HTK PROJECT NUMBER:
● 2312.03

SHEET NUMBER:
MP102

ORIGINAL CONTRACT DOCUMENTS



3639 SW Sumnerfield Drive, Suite A
Topeka, Kansas, 66614-2374
8624 College Boulevard, Suite 102
Overland Park, Kansas 66210
Telephone: (785) 233-3332
Email: lsand@lsand.com
LSA PROJECT NO. 2405005



7/16/2024

DATE:
 • July 15, 2024

REVISED DATE:
 •
 •
 •

MABEE LIBRARY RENOVATION

Washington University
 1800 SW 19th Street, Topeka, KS 66621

SHEET CONTENTS:
 • LOWER LEVEL FLOOR PLAN - POWER

HTK PROJECT NUMBER:
 • 2312.03

SHEET NUMBER:
 E101

ORIGINAL CONTRACT DOCUMENTS

- LEGEND:**
- 1 CONNECT TO EXISTING CIRCUIT
 - 2 CEILING MOUNTED RECEPTACLE WITH CORD REEL AND QUADPLEX AT END.
 - 3 100A 208V 3PH DS, NON-FUSED, NEMA 1
 - 4 JUNCTION BOX FOR X-RAY EQUIPMENT COORDINATE CONNECTION WITH EXISTING RELOCATED EQUIPMENT
 - 5 (3) #3 AND (1) #8 GRD IN 1 1/4" C
 - 6 REPLACE WITH NEW GFI RECEPTACLE.
 - 7 PROVIDE HOSPITAL GRADE RECEPTACLES FOR ALL DEVICES WITHIN THIS AREA.



1 LOWER LEVEL FLOOR PLAN
 POWER
 1/8" = 1'-0"

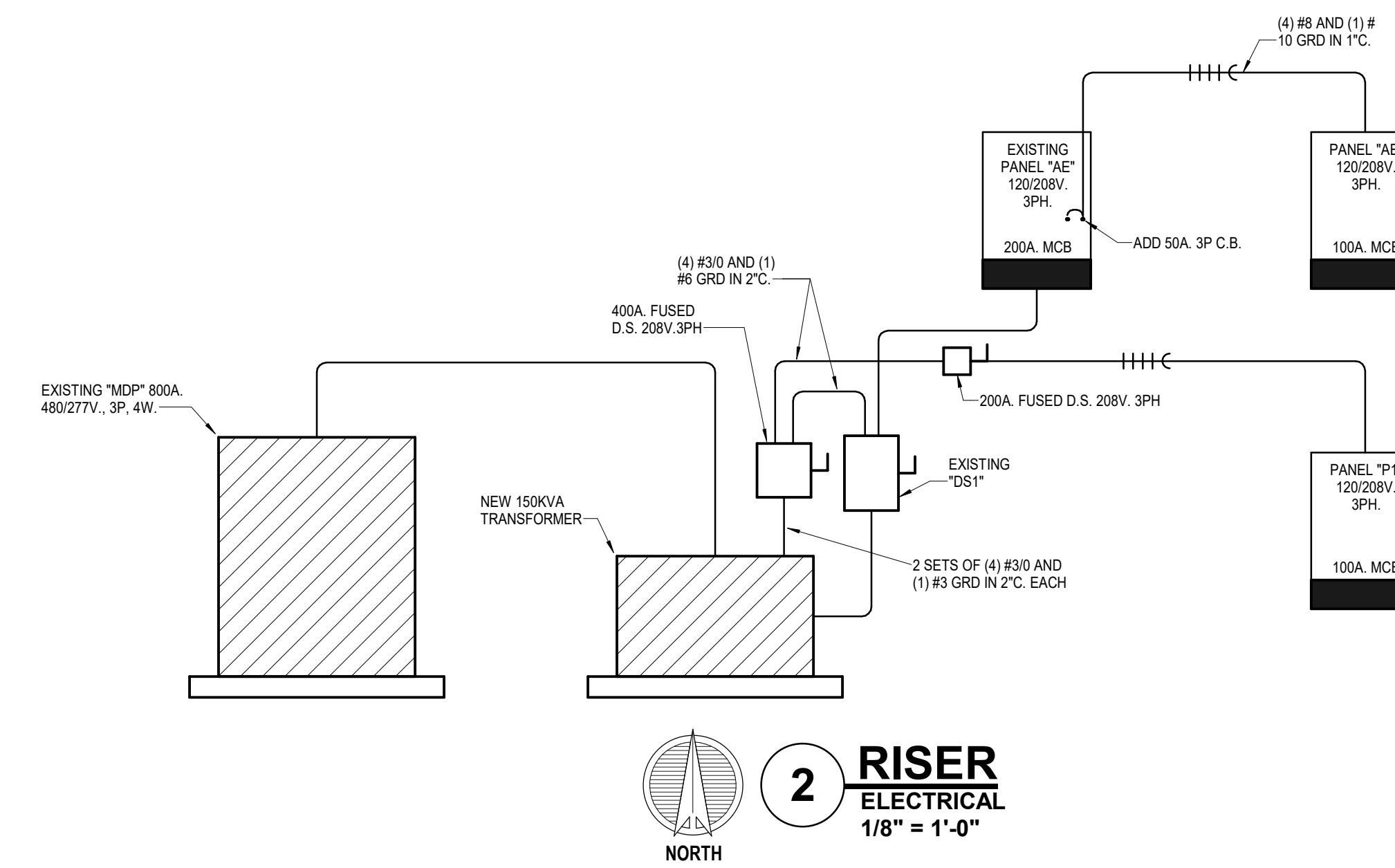

2 RISER ELECTRICAL
 1/8" = 1'-0"

LS&A
 CONSULTING ENGINEERS
 Letter: Summers & Associates P.A.
 3839 SW Sumnerfield Drive, Suite A
 Topeka, Kansas, 66614-2314
 8625 College Boulevard, Suite 102
 Overland Park, Kansas 66210
 Telephone: (785) 233-3332
 Email: lsand@lsand.com
 LSA PROJECT NO. 2405005

7/16/2024 11:53:30 AM Autodesk Docs://Mabee Library R23 - LSA MEP/Mabee Library MEP R23.rvt

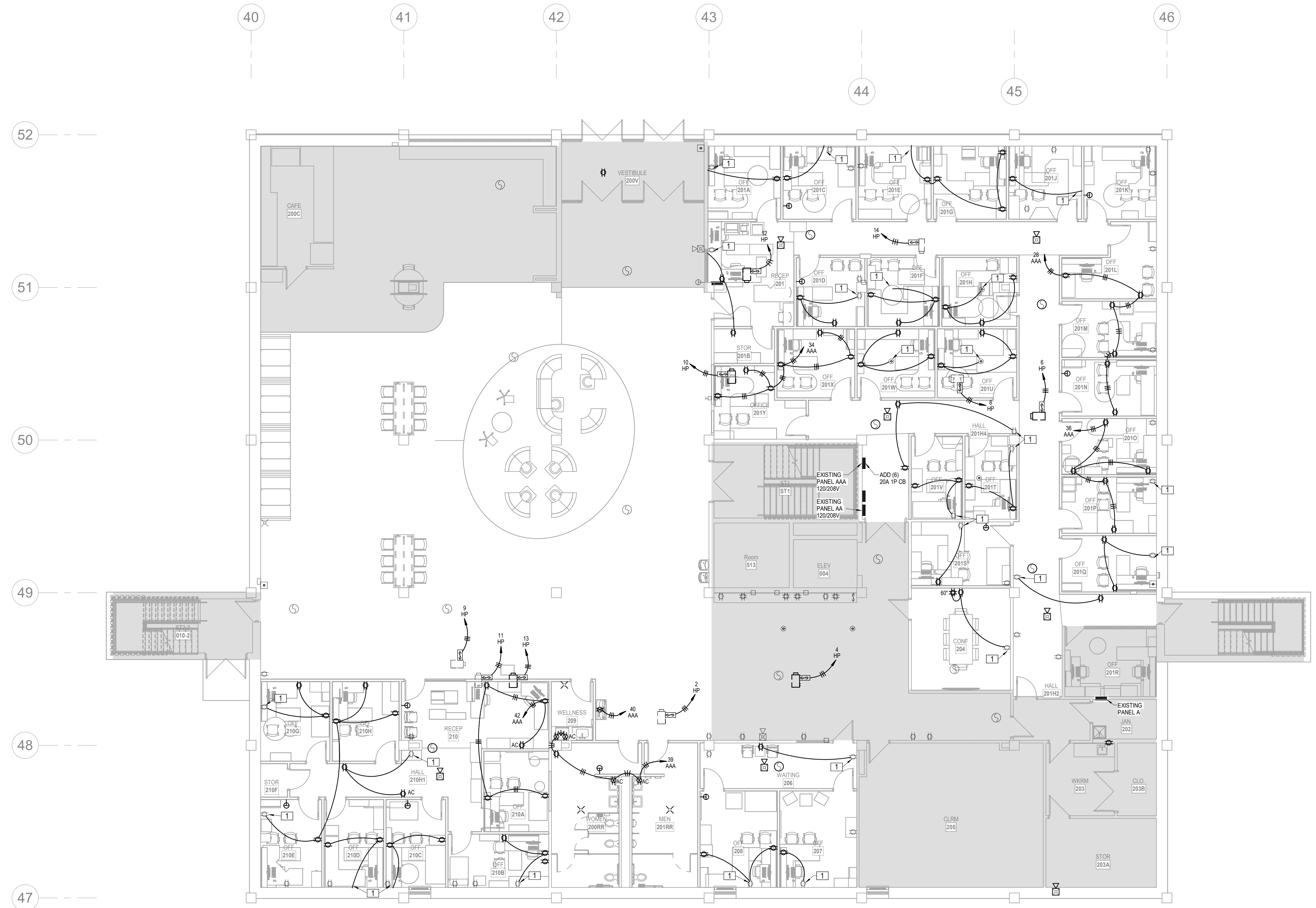

1 MAIN LEVEL FLOOR PLAN
POWER
1/8" = 1'-0"

- LEGEND:
- 1 CONNECT TO EXISTING CIRCUIT
 - 2 CEILING MOUNTED RECEPTACLE WITH CORD REEL AND QUADPLEX AT END.
 - 3 100A 208V 3PH DS, NON-FUSED, NEMA 1
 - 4 JUNCTION BOX FOR X-RAY EQUIPMENT COORDINATE CONNECTION WITH EXISTING RELOCATED EQUIPMENT
 - 5 (3) #3 AND (1) #8 GRD IN 1 1/4"
 - 6 REPLACE WITH NEW GFI RECEPTACLE.
 - 7 PROVIDE HOSPITAL GRADE RECEPTACLES FOR ALL DEVICES WITHIN THIS AREA.



DATE:
 • July 15, 2024
 REVISED DATE:
 •

MABEE LIBRARY RENOVATION

Washburn University
 1800 SW 19th Street, Topeka, KS 66621

LS&A
 CONSULTING ENGINEERS
 Littleton, Summers & Associates P.A.
 3839 SW Sumnerfield Drive, Suite A
 Topeka, Kansas, 66614-2374
 8625 College Boulevard, Suite 102
 Overland Park, Kansas 66210
 Telephone: (785) 233-3332
 Email: lsand@lsand.com
 LSA PROJECT NO. 2405005

SHEET CONTENTS:
 • MAIN LEVEL FLOOR PLAN
 - POWER
 HTK PROJECT NUMBER:
 • 2312.03
 SHEET NUMBER:
E102
 ORIGINAL CONTRACT DOCUMENTS

7/16/2024 11:53:33 AM Autodesk Docs://Mabee Library R23 - LSA MEP/Mabee Library MEP R23.rvt

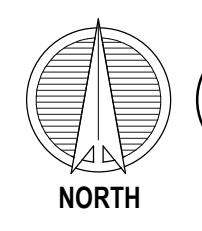
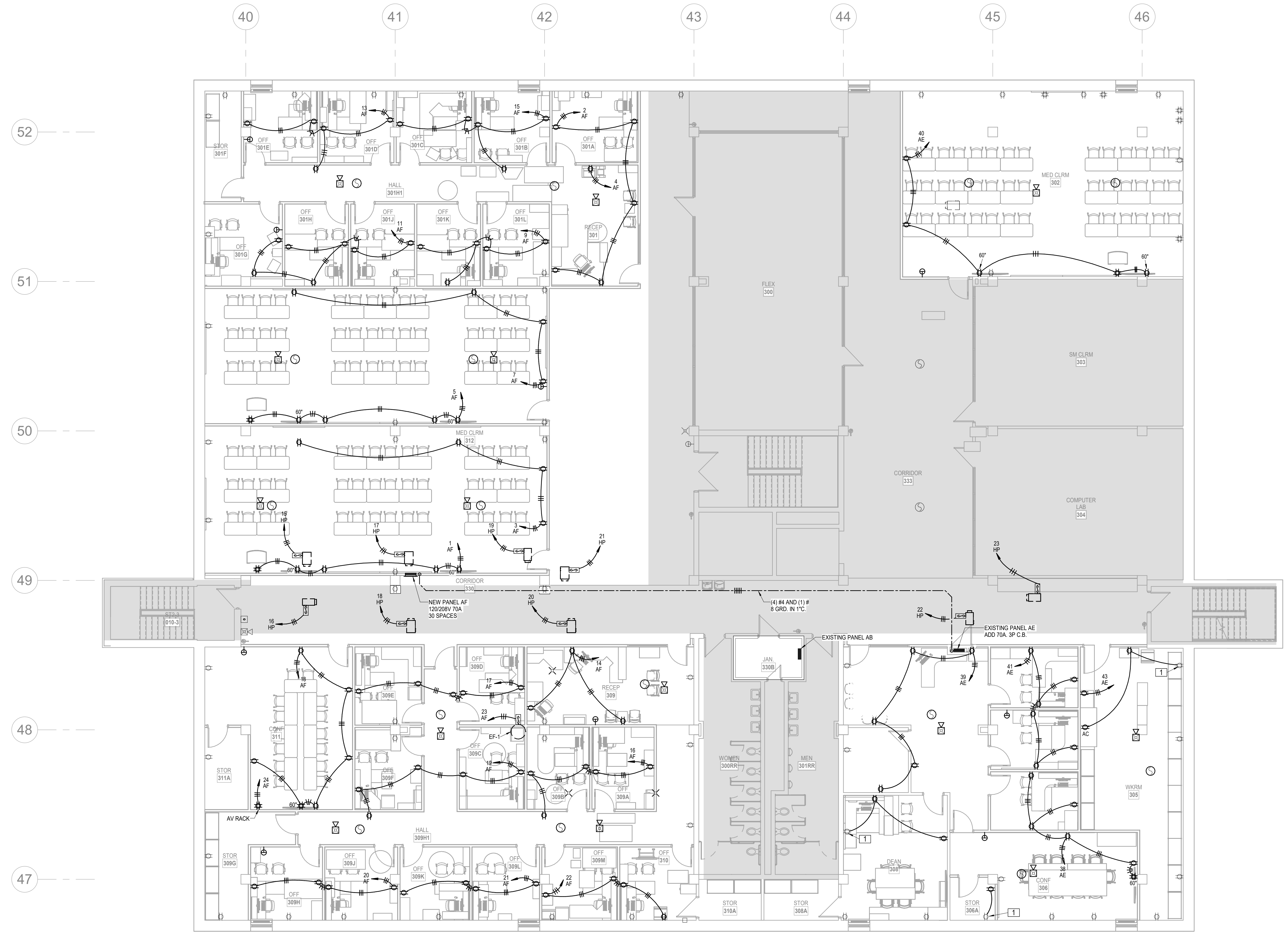

1 UPPER LEVEL FLOOR PLAN
POWER
1/8" = 1'-0"

- LEGEND:
- 1 CONNECT TO EXISTING CIRCUIT
 - 2 CEILING MOUNTED RECEPTACLE WITH CORD REEL AND QUADPLEX AT END.
 - 3 100A 208V 3PH DS, NON-FUSED, NEMA 1
 - 4 JUNCTION BOX FOR X-RAY EQUIPMENT COORDINATE CONNECTION WITH EXISTING RELOCATED EQUIPMENT
 - 5 (3) #3 AND (1) #8 GRD IN 1 1/4"
 - 6 REPLACE WITH NEW GFI RECEPTACLE.
 - 7 PROVIDE HOSPITAL GRADE RECEPTACLES FOR ALL DEVICES WITHIN THIS AREA.



DATE:
 • July 15, 2024
 REVISED DATE:
 •



SHEET CONTENTS:
 • UPPER LEVEL FLOOR PLAN - POWER
 HTK PROJECT NUMBER:
 • 2312.03
 SHEET NUMBER:
E103
 ORIGINAL CONTRACT DOCUMENTS

7/16/2024 11:53:33 AM Autodesk Docs://Mabee Library R23 - LSA MEP/Mabee Library MEP R23.rvt

LEGEND:	
1	CONNECT TO EXISTING CIRCUIT
2	CEILING MOUNTED RECEPTACLE WITH CORD REEL AND QUADPLEX AT END.
3	100A 208V 3PH DS. NON-FUSED, NEMA 1
4	JUNCTION BOX FOR X-RAY EQUIPMENT COORDINATE CONNECTION WITH EXISTING RELOCATED EQUIPMENT
5	(3) #3 AND (1) #8 GRD IN 1 1/4" C
6	REPLACE WITH NEW GFI RECEPTACLE.
7	PROVIDE HOSPITAL GRADE RECEPTACLES FOR ALL DEVICES WITHIN THIS AREA.

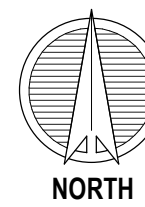
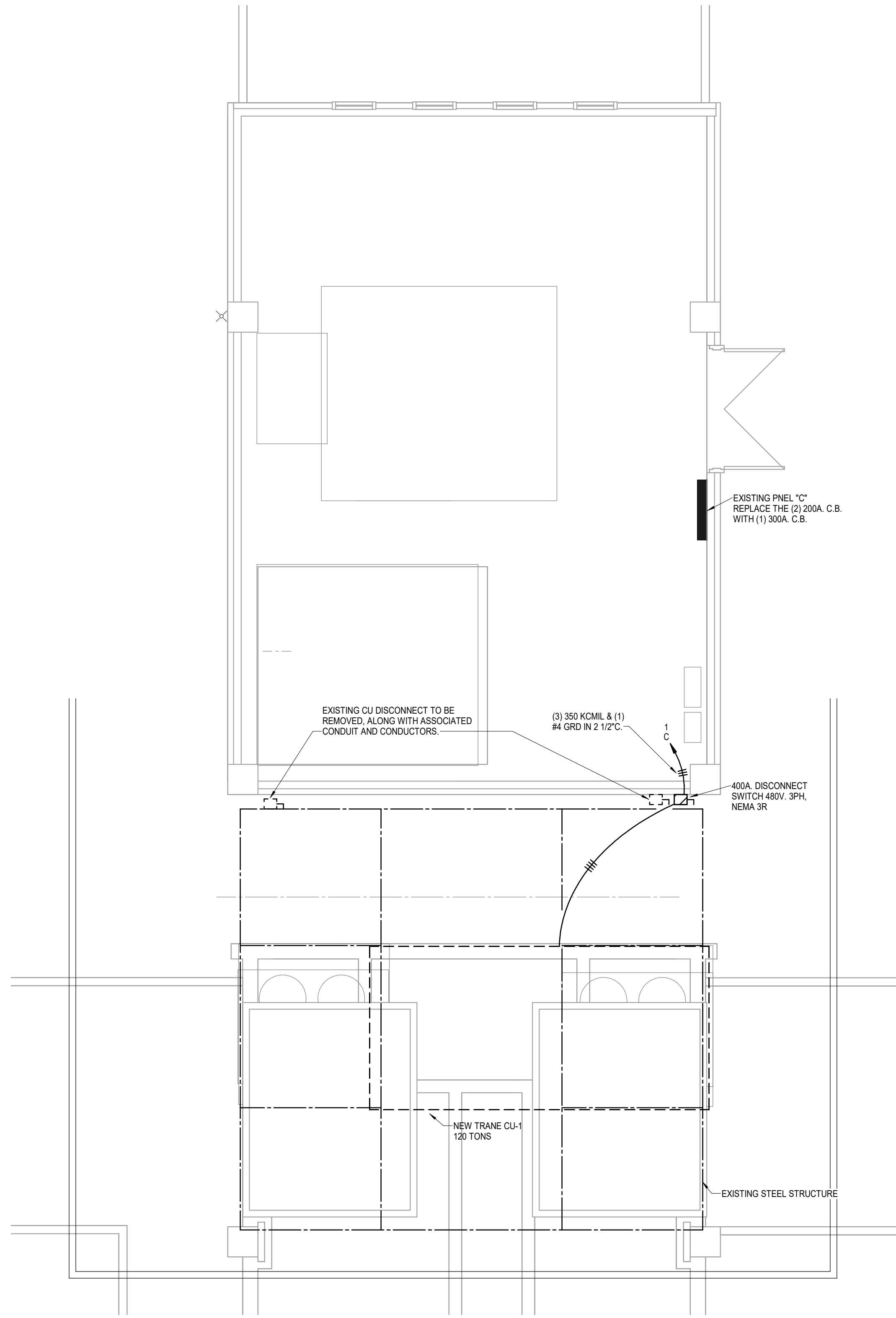

1 **PENTHOUSE PLAN**
POWER
1/4" = 1'-0"



7/16/2024

DATE:
• July 15, 2024

REVISED DATE:

-
-
-

MABEE LIBRARY RENOVATION

Washburn University
1800 SW 19th Street, Topeka, KS 66621

SHEET CONTENTS:
• PENTHOUSE FLOOR PLAN
• POWER

HTK PROJECT NUMBER:
• 2312.03

SHEET NUMBER:
E104

ORIGINAL CONTRACT DOCUMENTS



LIGHT FIXTURE SCHEDULE										
MARK	MANUFACTURER	CATALOG NUMBER	MOUNTING				FINISH	SOURCE		REMARKS
			RECESSED	SURFACE	WALL	PENDANT		TYPE	CODE	
"A"	RAB	EZPANHE 2X4 46 N/D10	X				WHITE	LED	6,150LUM/46W	1
"B"	RAB	EZPANHE 2X2 30 N/D10	X				WHITE	LED	4,136LUM/30W	1
"B1"	RAB	EZPANHE 2X2 30 N/D11 SMKEZPAN		X			WHITE	LED	4,136LUM/30W	1
"C"	RAB	WFLR8239FADWS	X				WHITE	LED	1,960LUM/23W	1, 3
"D"	HEALTHCARE LIGHTING	HPW348 MVOLT LED40 1U2D S2L FW			X		WHITE	LED	6087LUM/60W	6
"E"	DUAL LITE	EV4R	X				WHITE	LED	4W	5
"X"	DUAL LITE	LEW(C) * G * NE		X	X		ALUMINUM	LED	1.1W	2, 4

NOTES:

- 1 ALL FIXTURES 277V UNLESS NOTED OTHERWISE
- 2 ALL FIXTURES 4000K COLOR TEMPERATURE UNLESS NOTED OTHERWISE

REMARKS:

- 1 0-10V DIMMING DRIVER
- 2 VERIFY MOUNTING TYPE, ARROWS AND FACES WITH FLOOR PLAN.
- 3 IC RATED
- 4 COORDINATE MOUNTING HEIGHT WITH ARCHITECT.
- 5 EMERGENCY EGRESS FIXTURE, NORMALLY OFF.
- 6 VERIFY MOUNTING HEIGHT WITH ARCHITECT

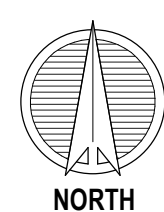
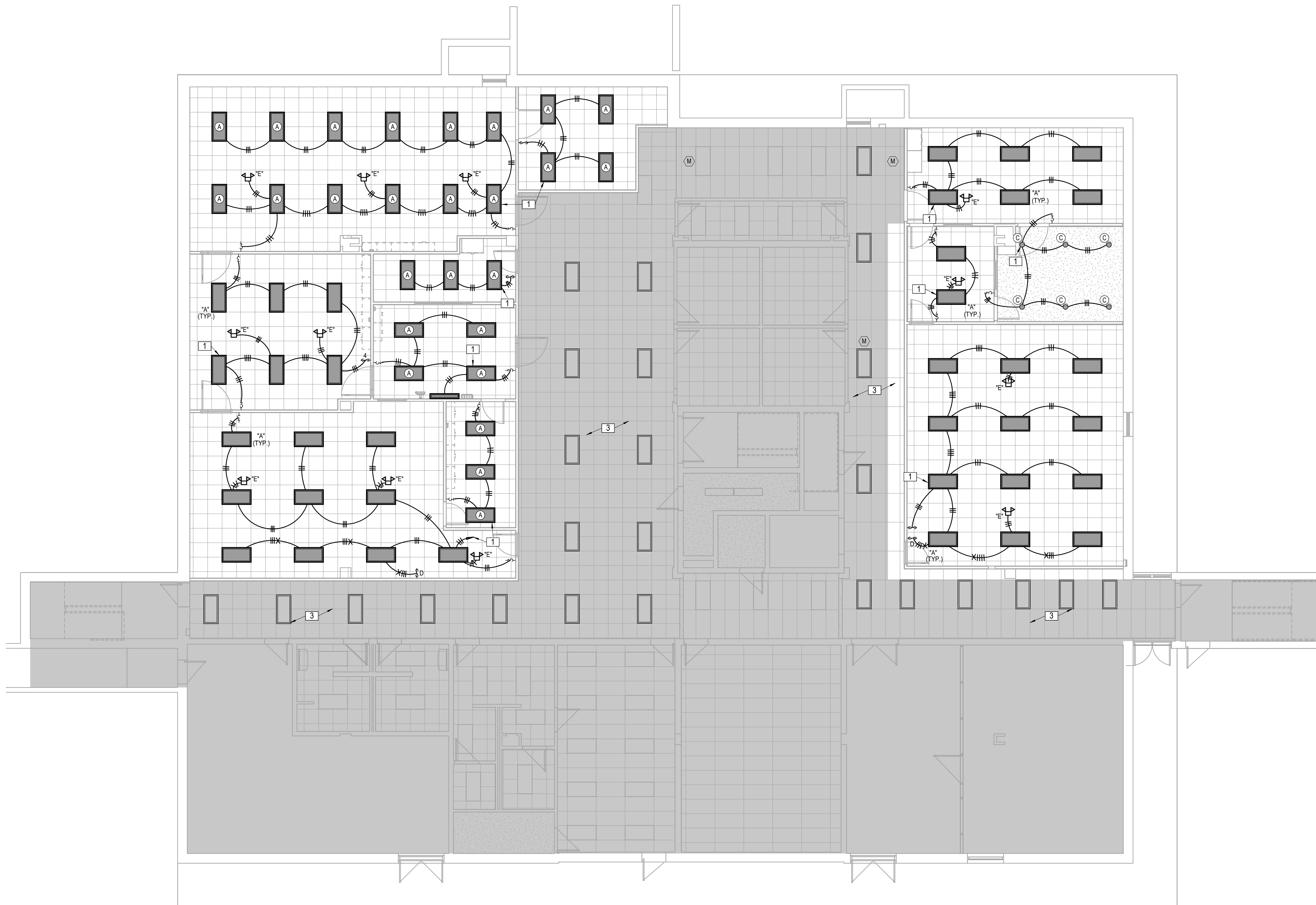

1 LOWER LEVEL CEILING PLAN
LIGHTING
1/8" = 1'-0"

LEGEND:	
1	CONNECT TO EXISTING LIGHTING CIRCUIT.
2	RE-CIRCUIT LIGHTING IN THIS ROOM TO NEW WALL SWITCH.
3	ADJUST CIRCUITING IN THIS AREA TO MAINTAIN CONTINUITY OF LIGHTING CIRCUIT.

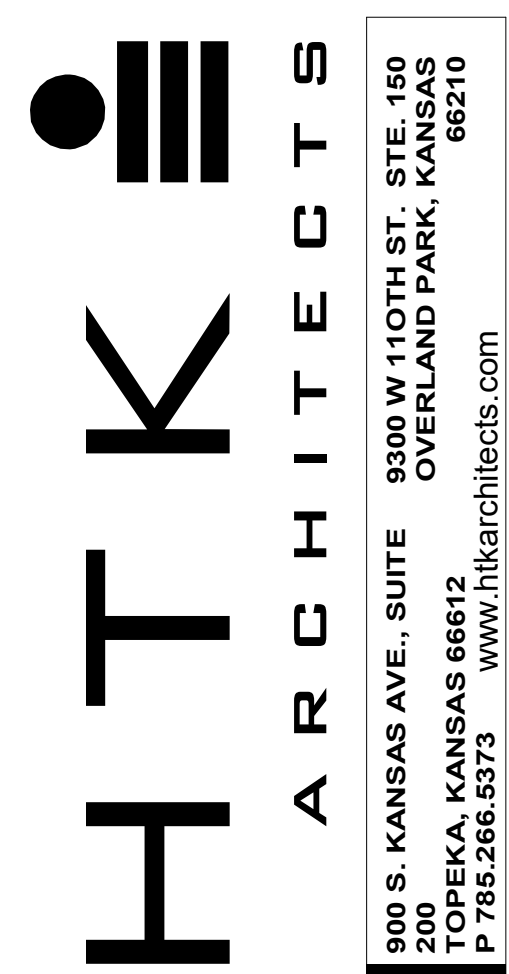

7/16/2024

DATE:
• July 15, 2024

REVISED DATE:
•
•
•

MABEE LIBRARY RENOVATION

Washburn University
1800 SW 19th Street, Topeka, KS 66621

SHEET CONTENTS:
• LOWER LEVEL FLOOR PLAN - LIGHTING

HTK PROJECT NUMBER:
• 2312.03

SHEET NUMBER:
E201

ORIGINAL CONTRACT DOCUMENTS



7/16/2024 11:53:34 AM Autodesk Docs://Mabee Library R23 - LSA MEP/Mabee Library MEP R23.rvt

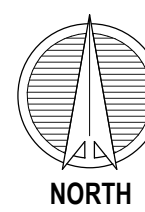
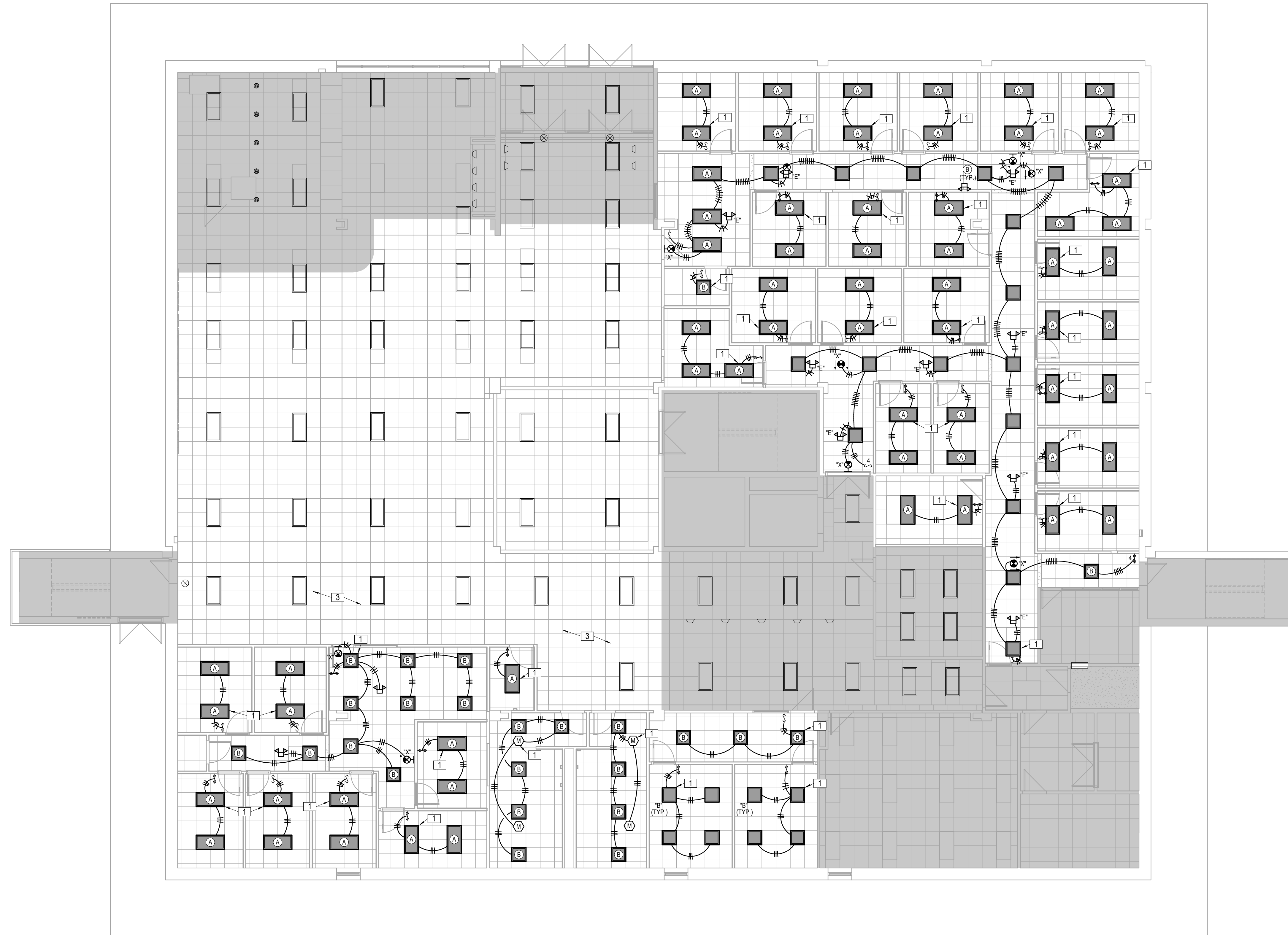

1 MAIN LEVEL CEILING PLAN
LIGHTING
1/8" = 1'-0"

- LEGEND:**
- 1 CONNECT TO EXISTING LIGHTING CIRCUIT.
 - 2 RECIRCUIT LIGHTING IN THIS ROOM TO NEW WALL SWITCH.
 - 3 ADJUST CIRCUITING IN THIS AREA TO MAINTAIN CONTINUITY OF LIGHTING CIRCUIT.

HTK ARCHITECTS
 650 S. KANSAS AVE., SUITE 400
 TOPEKA, KANSAS 66612
 P. 785.266.5373 www.htkarchitects.com



7/16/2024

DATE:
• July 15, 2024

REVISED DATE:
•
•
•

MABEE LIBRARY RENOVATION

Washburn University

1800 SW 19th Street, Topeka, KS 66621

SHEET CONTENTS:
• MAIN LEVEL FLOOR PLAN
• LIGHTING

HTK PROJECT NUMBER:
• 2312.03

SHEET NUMBER:
E202

ORIGINAL CONTRACT DOCUMENTS

LS&A
 CONSULTING ENGINEERS
 Letter: Summers & Associates P.A.
 3839 SW Sumnerfield Drive, Suite A
 Topeka, Kansas, 66614-2374
 8625 College Boulevard, Suite 102
 Overland Park, Kansas 66210
 Telephone: (785) 233-3332
 Email: lsand@lsaya.com
 LSA PROJECT NO. 2405005

7/16/2024 11:53:35 AM Autodesk Docs://Mabee Library R23 - LSA MEP/Mabee Library MEP R23.rvt

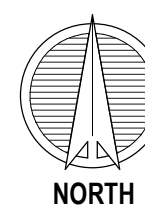
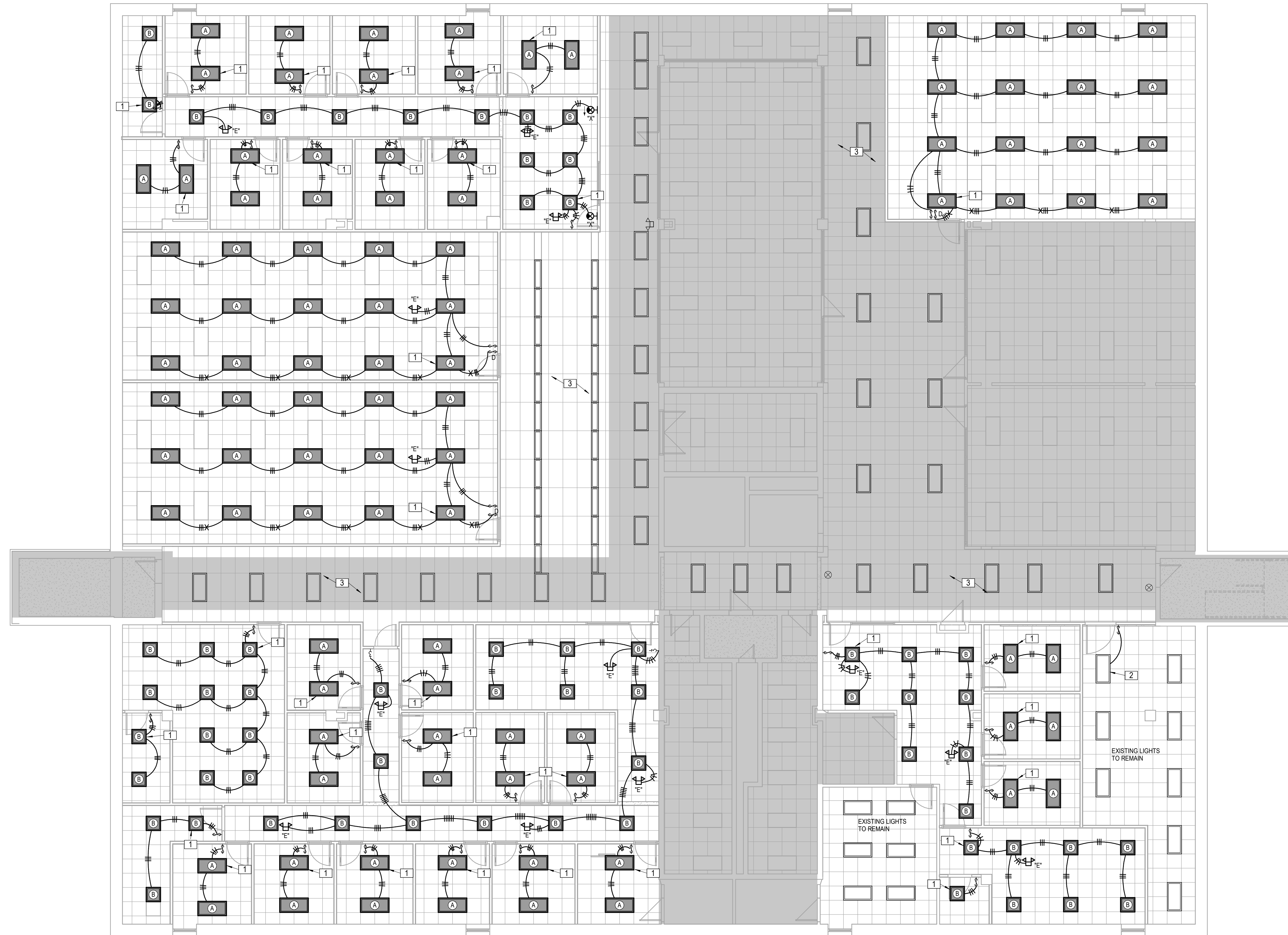

1 UPPER LEVEL CEILING PLAN
LIGHTING
1/8" = 1'-0"

- LEGEND:**
- 1 CONNECT TO EXISTING LIGHTING CIRCUIT.
 - 2 RECIRCUIT LIGHTING IN THIS ROOM TO NEW WALL SWITCH.
 - 3 ADJUST CIRCUITING IN THIS AREA TO MAINTAIN CONTINUITY OF LIGHTING CIRCUIT.



7/16/2024

DATE:
• July 15, 2024

REVISED DATE:
•
•
•

MABEE LIBRARY RENOVATION

Washburn University
1800 SW 19th Street, Topeka, KS 66621

SHEET CONTENTS:
• UPPER LEVEL FLOOR
PLAN - LIGHTING

HTK PROJECT NUMBER:
• 2312.03

SHEET NUMBER:
E203

ORIGINAL CONTRACT DOCUMENTS

LS&A
Consulting Engineers
3639 SW Sumnerfield Drive, Suite A
Topeka, Kansas, 66614-2374
8625 College Boulevard, Suite 102
Overland Park, Kansas 66210
Telephone: (785) 233-3332
Email: lsand@lsand.com
LSA PROJECT NO. 2405005

HTK ARCHITECTS
650 S. KANSAS AVE., SUITE 650
TOPEKA, KANSAS 66612
P. 785.266.5373 www.htkarchitects.com

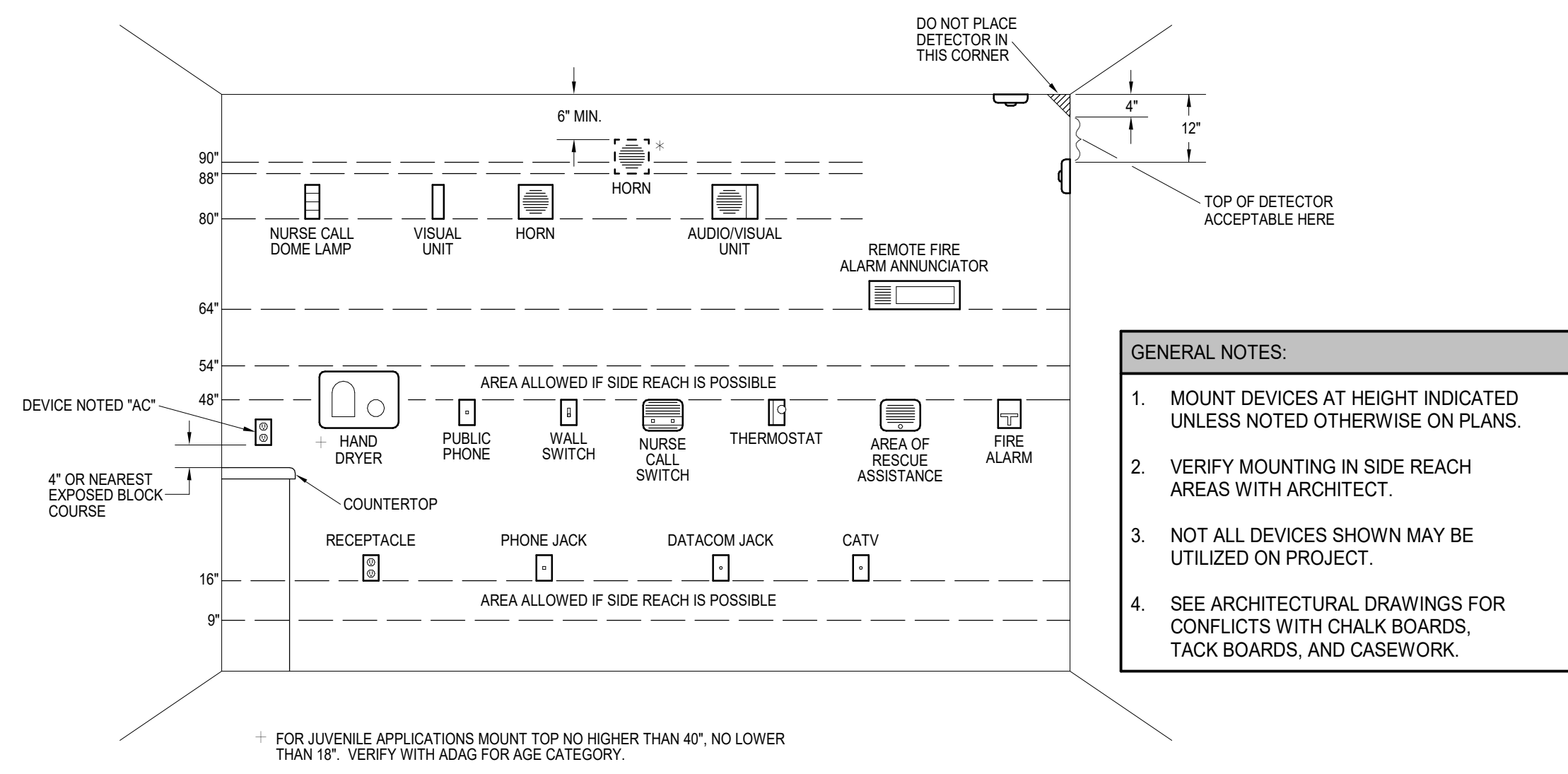

1 ELECTRICAL DEVICE MOUNTING HEIGHTS
NOT TO SCALE

- DEVICE MOUNTING NOTES:**
- VISUAL UNIT**
DEVICE BOTTOM 80" ABOVE HIGHEST FLOOR LEVEL OR TOP 6" BELOW CEILING, WHICHEVER IS LOWER.
 - AUDIO UNIT**
DEVICE BOTTOM 80" ABOVE HIGHEST FLOOR LEVEL OR TOP 6" BELOW CEILING, WHICHEVER IS LOWER.
 - AUDIOVISUAL UNIT**
DEVICE BOTTOM 80" ABOVE HIGHEST FLOOR LEVEL AND NOT LESS THAN 6" BELOW CEILING (NFPA) (BOTTOM AT 88" WITH BLOCK COURSES). MOUNT AT NFPA HEIGHT ONLY IF REQUIRED BY LOCAL AHJ.
 - PULL STATION**
HIGHEST OPERABLE PART SHALL NOT BE MORE THAN 48" ABOVE THE FLOOR (FRONT APPROACH).
- ELECTRICAL DEVICE MOUNTING HEIGHTS SHALL CONFORM TO THE LATEST EDITION OF THE ADA STANDARDS FOR ACCESSIBLE DESIGN.

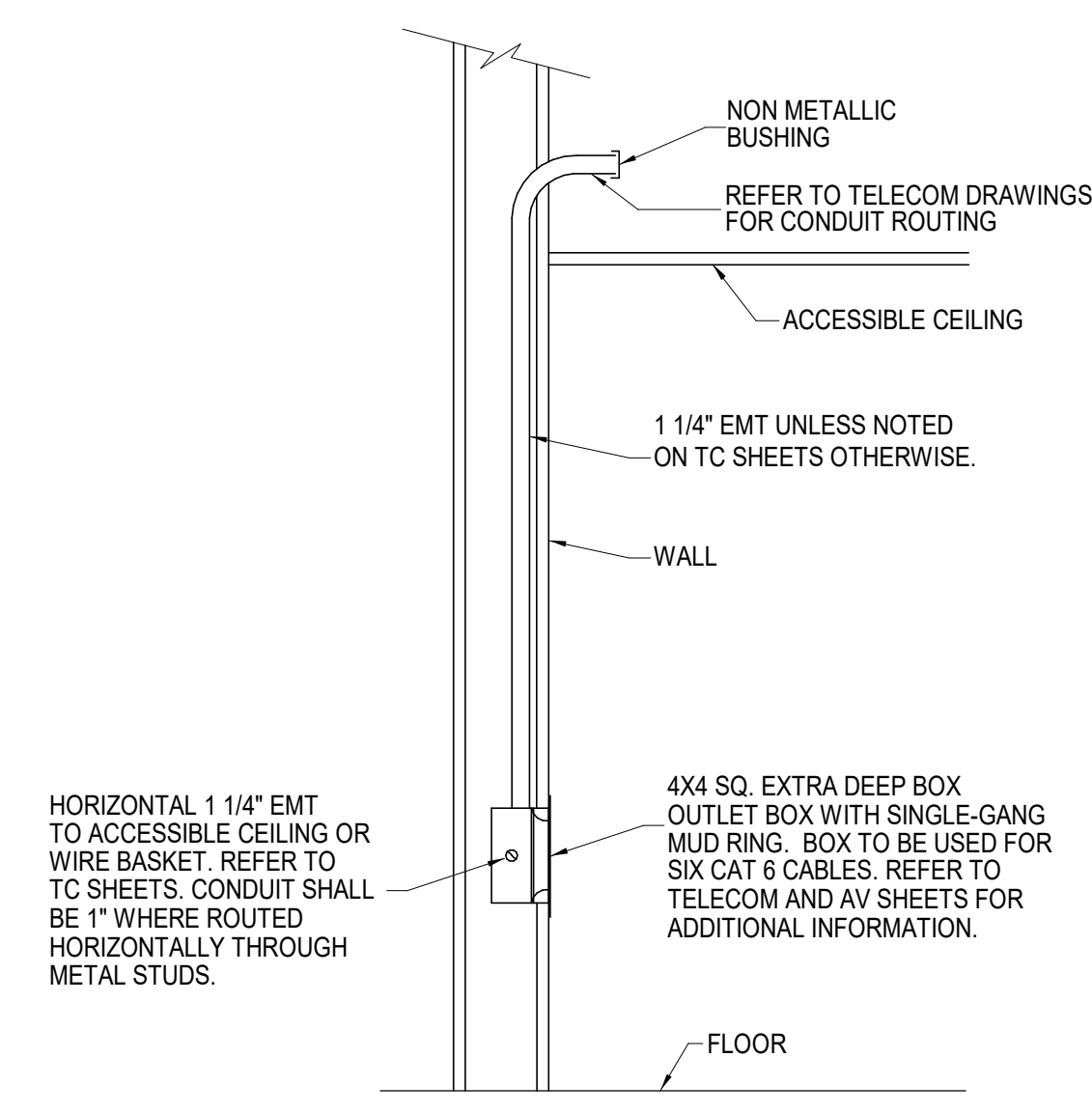

3 TELECOM/AV OUTLET DETAIL
NOT TO SCALE

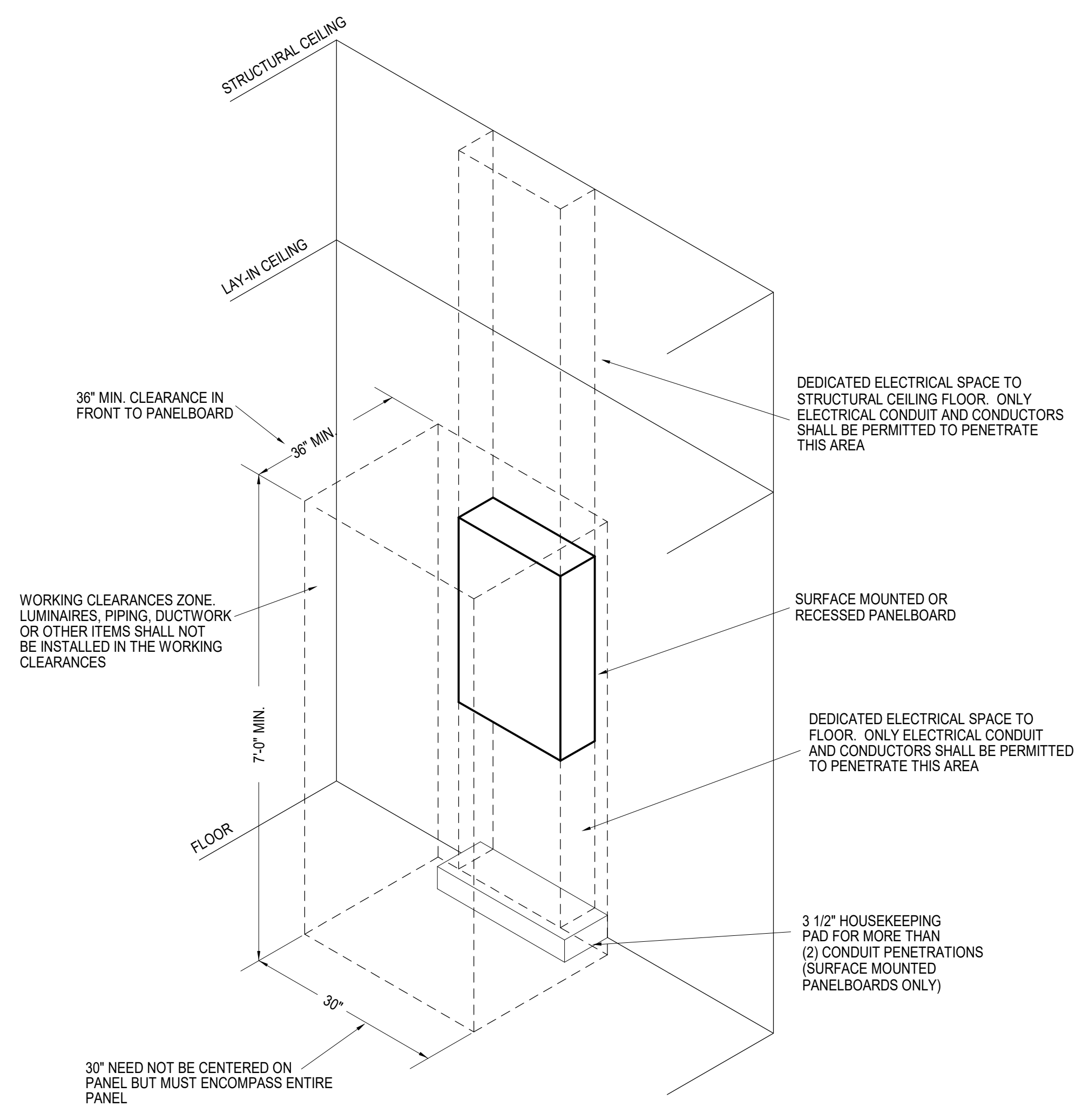

NOTE:
COORDINATE ALL WORK WITH OTHER TRADES. MAINTAIN ALL OTHER NEC CLEARANCES AND REQUIREMENTS.

2 PANELBOARD INSTALLATION DETAIL
NOT TO SCALE

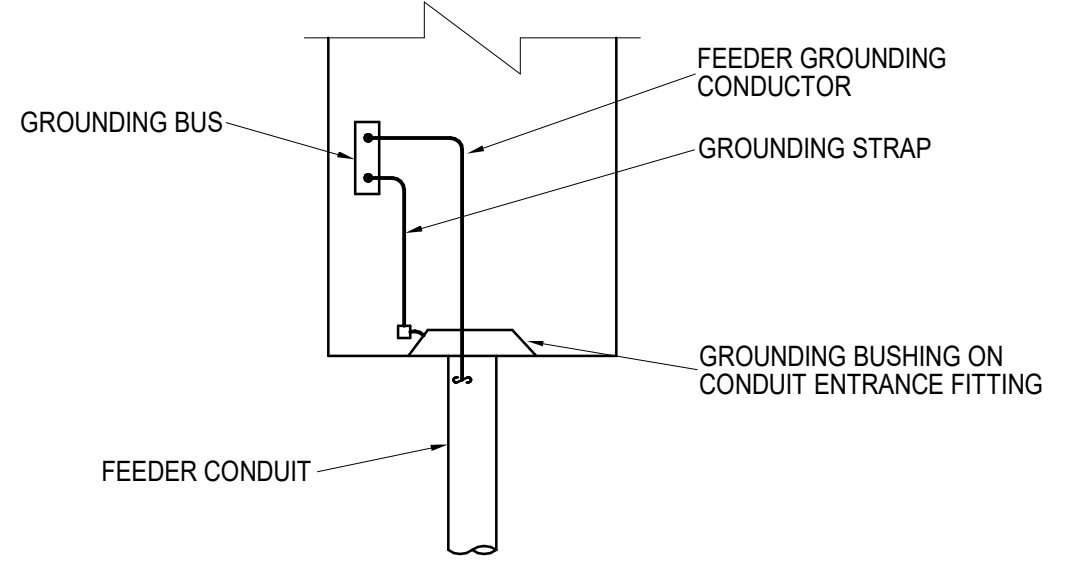

4 PANEL GROUNDING DETAIL
NOT TO SCALE



7/16/2024

DATE:
● July 15, 2024
REVISED DATE:
●
●
●

MABEE LIBRARY RENOVATION

Washburn University
1800 SW 19th Street, Topeka, KS 66621

SHEET CONTENTS:
● ELECTRICAL DETAILS
HTK PROJECT NUMBER:
● 2312.03
SHEET NUMBER:
E301
ORIGINAL CONTRACT DOCUMENTS



Panel: P1

Location: Volts: 120/208 Wye A.I.C. Rating: 22K
 Supply From: Phases: 3 Mains Type: MCB
 Mounting: Wires: 4 Mains Rating: 225 A
 Enclosure: MCB Rating: 200

Notes:

CKT	Circuit Description	Trip	Wire Size	A	B	C	Wire Size	Trip	Circuit Description	CKT
1	Receptacle 118A	20 A	12	180	9000					2
3	Heat Unit Receptacle	20 A	12		0	9000		3	100 A X-RAY EQUIPMENT	4
5	Receptacle 118A	20 A	12			180	9000			6
7	Receptacle 118C	20 A	12	400	167					8
9	Receptacle 118C	20 A	12		400	167		6	60 A TVSS	10
11	Receptacle 118B	20 A	12			180	167			12
13	Receptacle 118	20 A	12	1200	500			12	20 A TUBESTAND X-RAY CONTROL	14
15	Receptacle 118	20 A	12		1600	500		12	20 A TABLE X-RAY CONTROL	16
17	Receptacle 118	20 A	12			800				18
19	Receptacle 118	20 A	12	1600						20
21	Receptacle 118	20 A	12		1600					22
23	Receptacle 118	20 A	12			1200				24
25	Receptacle 117	20 A	12	180						26
27	Receptacle 117	20 A	12		180					28
29	Receptacle 117A	20 A	12			360				30
31	Receptacle 117A	20 A	12	1120						32
33	Receptacle 117A	20 A	12		400					34
35	Receptacle 115	20 A	12			1960				36
37	Receptacle 115	20 A	12	720						38
39	Receptacle 115	20 A	12		720					40
41										42
Total Load:				15067 VA	14567 VA	13847 VA				
Total Amps:				126 A	122 A	115 A				

Legend:

Load Classification	Connected Load	Demand Factor	Estimated...	Panel Totals
Power	27500 VA	100.00%	27500 VA	
Receptacle	14980 VA	83.38%	12490 VA	Total Conn. Load: 43480 VA
HVAC Load	1000 VA	100.00%	1000 VA	Total Est. Demand: 40990 VA
				Total Conn.: 121 A
				Total Est. Demand: 114 A

Notes:

Panel: HP

Location: Volts: 480/277 Wye A.I.C. Rating: 22K
 Supply From: Phases: 3 Mains Type: MCB
 Mounting: Wires: 4 Mains Rating: 225 A
 Enclosure: MCB Rating: 100

Notes:

CKT	Circuit Description	Trip	Wire Size	A	B	C	Wire Size	Trip	Circuit Description	CKT
1	VAV BOX	20 A	12	4000	1500			12	20 A VAV BOX	2
3	VAV BOX	20 A	12		3500	2000		12	20 A VAV BOX	4
5	VAV BOX	20 A	12			4000	3000	12	20 A VAV BOX	6
7	VAV BOX	20 A	12	2500	3000			12	20 A VAV BOX	8
9	VAV BOX	20 A	12		1000	2000		12	20 A VAV BOX	10
11	VAV BOX	20 A	12			2000	2000	12	20 A VAV BOX	12
13	VAV BOX	20 A	12	2000	2000			12	20 A VAV BOX	14
15	VAV BOX	20 A	12		4000	3000		12	20 A VAV BOX	16
17	VAV BOX	20 A	12		4000	3000		12	20 A VAV BOX	18
19	VAV BOX	20 A	12	2000	4000			12	20 A VAV BOX	20
21	VAV BOX	20 A	12		4000	2000		12	20 A VAV BOX	22
23	VAV BOX	20 A	12			3000				24
25										26
27										28
29										30
31										32
33										34
35										36
37										38
39										40
41										42
Total Load:				21000 VA	21500 VA	21000 VA				
Total Amps:				76 A	78 A	76 A				

Legend:

Load Classification	Connected Load	Demand Factor	Estimated...	Panel Totals
Power	63500 VA	100.00%	63500 VA	
HVAC Load				Total Conn. Load: 63500 VA
				Total Est. Demand: 63500 VA
				Total Conn.: 176 A
				Total Est. Demand: 76 A

Notes:

Panel: AF

Location: Volts: 120/208 Wye A.I.C. Rating: 10K
 Supply From: PANEL AE Phases: 3 Mains Type: MLO
 Mounting: RECESSED Wires: 4 Mains Rating: 100 A
 Enclosure: MCB Rating:

Notes:

CKT	Circuit Description	Trip	Wire Size	A	B	C	Wire Size	Trip	Circuit Description	CKT
1	Receptacle 313	20 A	1120	900				20 A	Receptacle 315A	2
3	Receptacle 313	20 A			720	180		20 A	Receptacle	4
5	Receptacle 314	20 A				1120				6
7	Receptacle 314	20 A		720						8
9	Receptacle 315K	20 A			900					10
11	Receptacle 315I	20 A				1260				12
13	Receptacle 315D	20 A		900	540			20 A	Receptacle 311	14
15	Receptacle 315B	20 A			900	900		20 A	Receptacle 311F	16
17	Receptacle 311B	20 A				900	1300	20 A	Receptacle 312	18
19	Receptacle 311D	20 A		900	720			20 A	Receptacle 311K	20
21	Receptacle 311I	20 A			720	720		20 A	Receptacle 311H	22
23	HVAC Load 311B	20 A				0	400	20 A	Receptacle 312	24
25										26
27										28
29										30
31										32
33										34
35										36
37										38
39										40
41										42
Total Load:				5800 VA	5040 VA	4980 VA				
Total Amps:				48 A	42 A	42 A				

Legend:

Load Classification	Connected Load	Demand Factor	Estimated...	Panel Totals
Receptacle	15820 VA	81.61%	12910 VA	
HVAC Load	0 VA	0.00%	0 VA	Total Conn. Load: 15820 VA
				Total Est. Demand: 12910 VA
				Total Conn.: 44 A
				Total Est. Demand: 36 A

Notes:

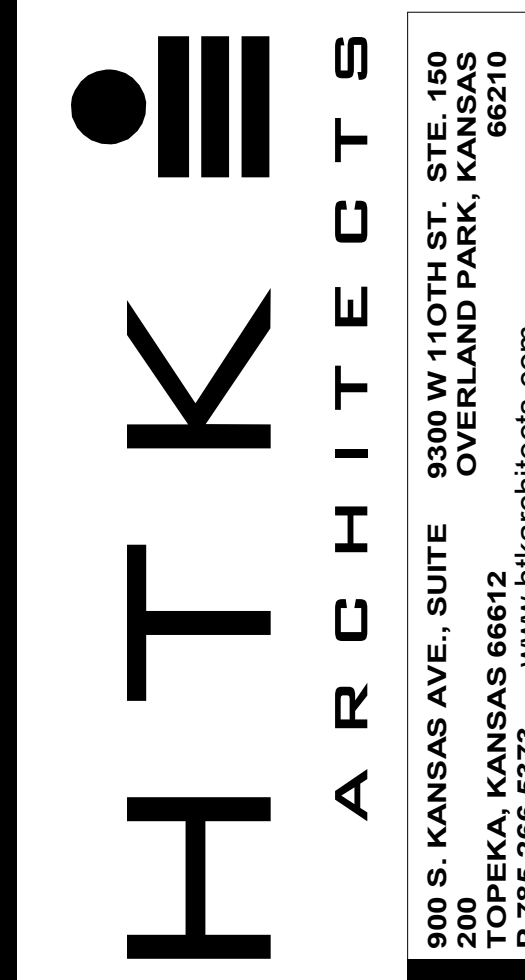

DATE:
 • July 15, 2024
 REVISED DATE:
 •

MABEE LIBRARY RENOVATION
 Washburn University
 1800 SW 19th Street, Topeka, KS 66621



SHEET CONTENTS:
 ELECTRICAL SCHEDULES
 HTK PROJECT NUMBER:
 • 2312.03
 SHEET NUMBER:
E302
 ORIGINAL CONTRACT DOCUMENTS

7/16/2024 11:53:43 AM Autodesk Docs://Mabee Library R23 - LSA MEP/Mabee Library MEP R23.rvt

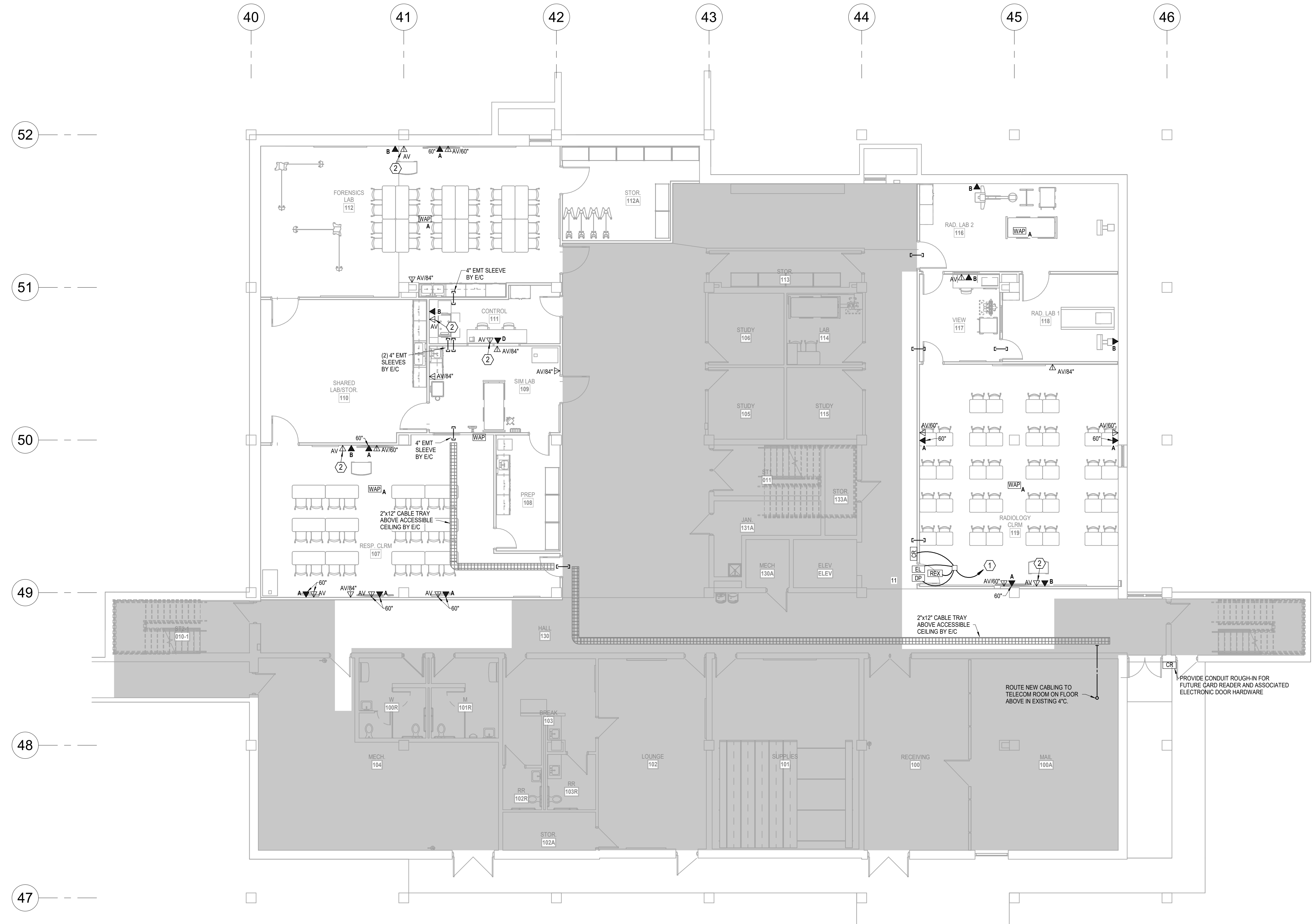

1 LOWER LEVEL FLOOR PLAN
TELECOM
 1/8" = 1'-0"

- NOTES:**
- COORDINATE WITH OWNER'S AV VENDOR (CYTEK) FOR EXACT CONDUIT/BACKBOX/POWER INFRASTRUCTURE REQUIREMENTS.
 - REFER TO SHEET T201 FOR ADDITIONAL GENERAL NOTES.
 - COORDINATE AND VERIFY CAMERA PLACEMENT AND VIEWS WITH THE OWNER.
- LEGEND:**
- CBS SHALL ROUTE ACCESS CONTROL COMBO CABLE TO EXISTING ACCESS CONTROL PANEL IN TELECOM ROOM AND TERMINATE ON BOTH ENDS. CONTRACTOR SHALL CONTACT CBS FOR PRICING TO BE INCLUDED IN BID.
 - PROVIDE (2) 1 1/4" EMT CONDUITS TO ABOVE ACCESSIBLE CEILING.
 - PROVIDE AV OUTLETS AT 18" AFF AND 60" AFF WITH CONNECTING 1 1/4" EMT CONDUIT. ADDITIONALLY PROVIDE 1 1/4" EMT CONDUIT FROM AV OUTLET AT 60" TO ABOVE ACCESSIBLE CEILING.
 - ROUTE CAT6 FROM CAMERA TO TELECOM ROOM AND TERMINATE ON BOTH ENDS. PROVIDE CAT6 PATCH CORD FROM CAMERA OUTLET TO CAMERA.

HTK ARCHITECTS
 658 W. 15TH ST. STE. 450
 OVERLAND PARK, KANSAS 66210
 P. 785.286.5373 www.htkarchitects.com

WASHBURN UNIVERSITY
 PROFESSIONAL DESIGNER
 7/16/2024

DATE:
 ● July 15, 2024

REVISED DATE:
 ●
 ●
 ●

MABEE LIBRARY RENOVATION

Washburn University
 1800 SW 19th Street, Topeka, KS 66621

SHEET CONTENTS:
 ● LOWER LEVEL FLOOR PLAN - TELECOM

HTK PROJECT NUMBER:
 ● 2312.03

SHEET NUMBER:
T101

ORIGINAL CONTRACT DOCUMENTS

LS&A
 CONSULTING ENGINEERS
 Lillian Summers & Associates P.A.
 3839 SW Sumnerfield Drive, Suite A
 Topeka, Kansas 66614-2374
 8625 College Boulevard, Suite 102
 Overland Park, Kansas 66210
 Telephone: (785) 233-3332
 Email: lsand@lsand.com
 LSA PROJECT NO. 2405005

7/16/2024 11:53:53 AM Autodesk Docs://Mabee Library R23 - LSA MEP/Mabee Library MEP R23.rvt

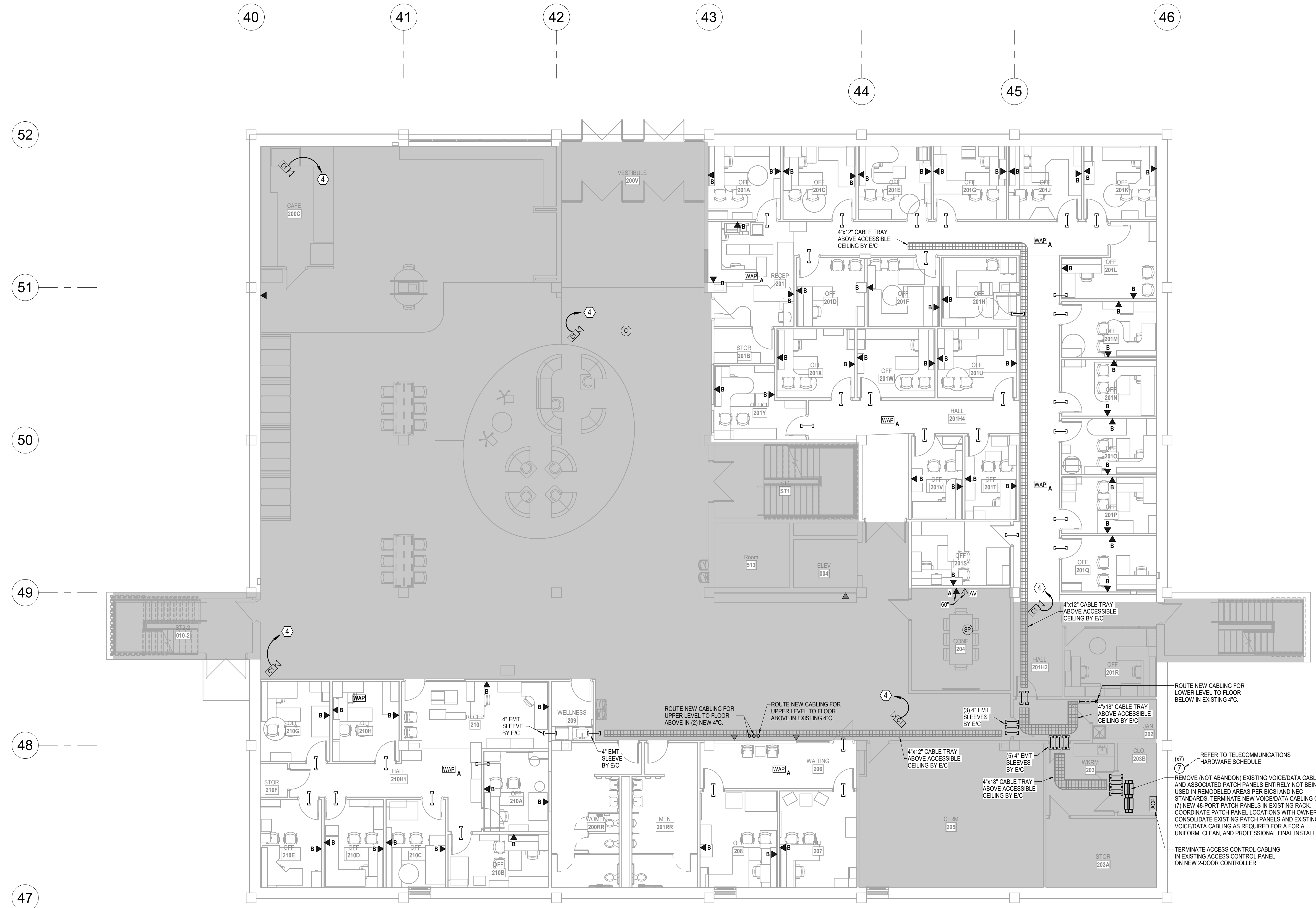

1 MAIN LEVEL FLOOR PLAN
TELECOM
1/8" = 1'-0"

- NOTES:**
- COORDINATE WITH OWNER'S AV VENDOR (CYTEK) FOR EXACT CONDUIT/BACKBOX/POWER INFRASTRUCTURE REQUIREMENTS.
 - REFER TO SHEET T201 FOR ADDITIONAL GENERAL NOTES.
 - COORDINATE AND VERIFY CAMERA PLACEMENT AND VIEWS WITH THE OWNER.

- LEGEND:**
- CBS SHALL ROUTE ACCESS CONTROL COMBO CABLE TO EXISTING ACCESS CONTROL PANEL IN TELECOM ROOM AND TERMINATE ON BOTH ENDS. CONTRACTOR SHALL CONTACT CBS FOR PRICING TO BE INCLUDED IN BID.
 - PROVIDE (2) 1 1/4" EMT CONDUITS TO ABOVE ACCESSIBLE CEILING.
 - PROVIDE AV OUTLETS AT 18" AFF AND 60" AFF WITH CONNECTING 1 1/4" EMT CONDUIT. ADDITIONALLY PROVIDE 1 1/4" EMT CONDUIT FROM AV OUTLET AT 60" TO ABOVE ACCESSIBLE CEILING.
 - ROUTE CAT6 FROM CAMERA TO TELECOM ROOM AND TERMINATE ON BOTH ENDS. PROVIDE CAT6 PATCH CORD FROM CAMERA OUTLET TO CAMERA.

HTK ARCHITECTS
658 W. 15TH ST. STE. 450
OVERLAND PARK, KANSAS 66210
P. 785.266.5273 www.htkarchitects.com



DATE:
● July 15, 2024

REVISED DATE:
●
●
●

MABEE LIBRARY RENOVATION

SHEET CONTENTS:
● MAIN LEVEL FLOOR PLAN
● TELECOM

HTK PROJECT NUMBER:
● 2312.03

SHEET NUMBER:
T102

ORIGINAL CONTRACT DOCUMENTS

LS&A
Consulting Engineers
3639 SW Sumnerfield Drive, Suite A
Topeka, Kansas, 66614-2374
8625 College Boulevard, Suite 102
Overland Park, Kansas 66210
Telephone: (785) 233-3332
Email: lsand@lsand.com
LSA PROJECT NO. 2405005

Washburn University
1800 SW 19th Street, Topeka, KS 66621

7/16/2024 11:54:04 AM Autodesk Docs://Mabee Library R23 - LSA MEP/Mabee Library MEP R23.rvt

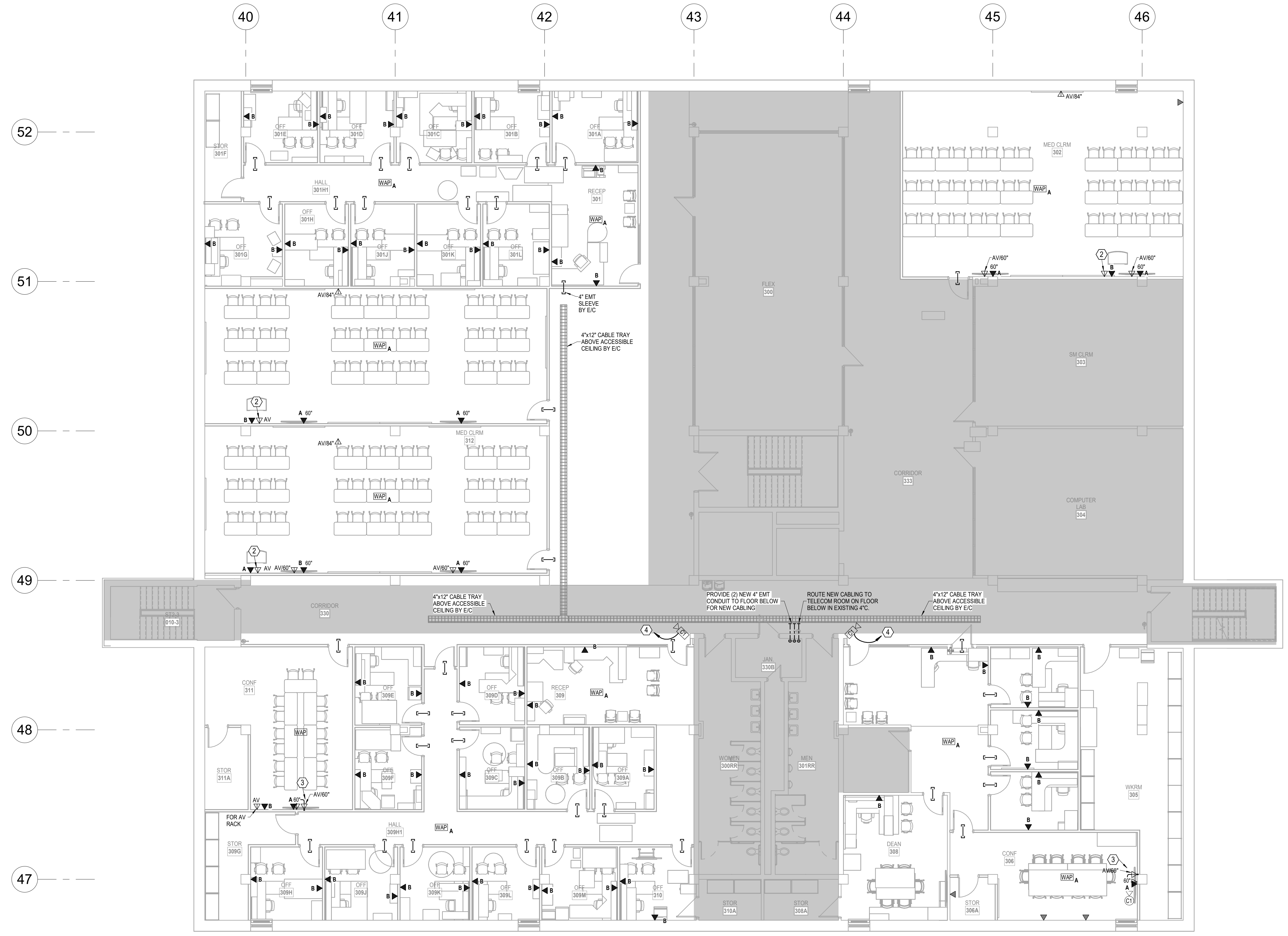

1 UPPER LEVEL FLOOR PLAN
TELECOM
1/8" = 1'-0"

- NOTES:**
- COORDINATE WITH OWNER'S AV VENDOR (CYTEK) FOR EXACT CONDUIT/BACKBOX/POWER INFRASTRUCTURE REQUIREMENTS.
 - REFER TO SHEET T201 FOR ADDITIONAL GENERAL NOTES.
 - COORDINATE AND VERIFY CAMERA PLACEMENT AND VIEWS WITH THE OWNER.
- LEGEND:**
- CBS SHALL ROUTE ACCESS CONTROL COMBO CABLE TO EXISTING ACCESS CONTROL PANEL IN TELECOM ROOM AND TERMINATE ON BOTH ENDS. CONTRACTOR SHALL CONTACT CBS FOR PRICING TO BE INCLUDED IN BID.
 - PROVIDE (2) 1 1/4" EMT CONDUITS TO ABOVE ACCESSIBLE CEILING.
 - PROVIDE AV OUTLETS AT 18" AFF AND 60" AFF WITH CONNECTING 1 1/4" EMT CONDUIT. ADDITIONALLY PROVIDE 1 1/4" EMT CONDUIT FROM AV OUTLET AT 60" TO ABOVE ACCESSIBLE CEILING.
 - ROUTE CAT6 FROM CAMERA TO TELECOM ROOM AND TERMINATE ON BOTH ENDS. PROVIDE CAT6 PATCH CORD FROM CAMERA OUTLET TO CAMERA.



DATE:
• July 15, 2024

REVISED DATE:
•
•
•

COMMUNICATION OUTLET SCHEDULE						
DESIGNATION	JACK DESCRIPTION	JACK COLOR	NETWORK	CABLE DESCRIPTION	COLOR	REMARKS
1	CATEGORY 6 RJ45 VOIP F-CONNECTOR	WHITE		CATEGORY 6, 4-PAIR UTP	WHITE	1
2	BLANK INSERT	GREY		RG-6, COAX CABLE	WHITE	1
4		GREY				1

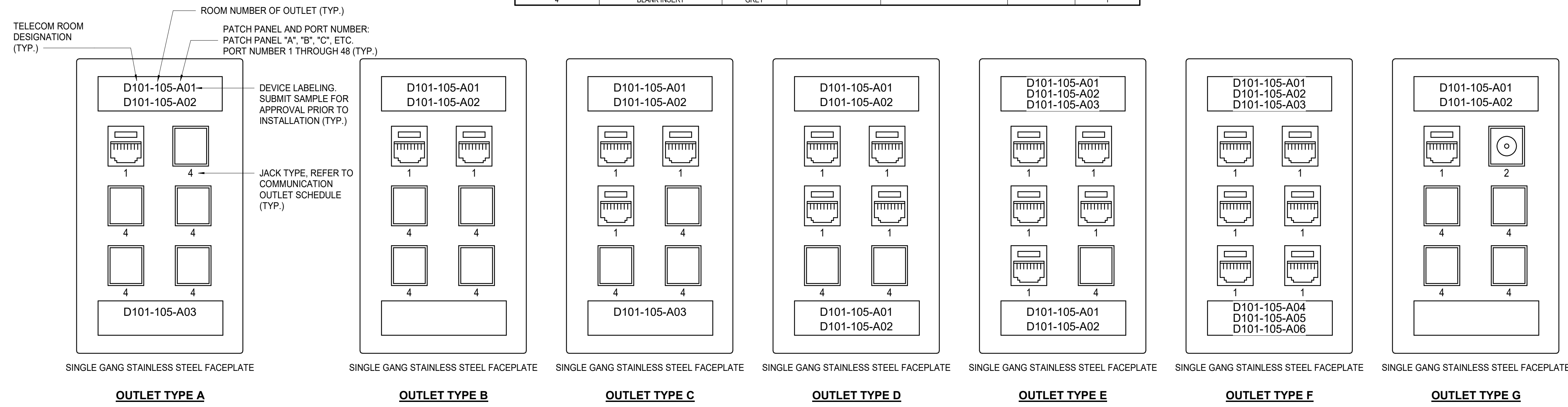

- NOTES:
- RUN EXPOSED FIBER IN 1 1/4" INNERDUCT CARLON RISER-GUARD/OPTI-GUARD DF4X1-200
 - VERIFY ROOM NUMBERS WITH OWNER PRIOR TO LABELING FACEPLATES AND PATCH PANELS.
 - PROVIDE BONDING JUMPERS BETWEEN ALL SECTIONS OF WIRE BASKET RUNWAY.
 - PROVIDE A #6 GREEN GROUND WIRE FROM BUSBAR TO ALL RACKS. LABEL ACCORDING TO OWNER SPECIFICATIONS. SEE DETAIL.
 - CONTRACTOR TO FIELD VERIFY ALL MEASUREMENTS PRIOR TO INSTALLATION.
 - PROVIDE LABELING OF ALL RACKS AND LOCATE ON TOP RAIL. SUBMIT SAMPLE TO OWNER FOR APPROVAL PRIOR TO INSTALLATION.
 - PROVIDE LABELING FOR ALL GROUND WIRE AT EVERY TERMINATION POINT. SUBMIT SAMPLE TO OWNER FOR APPROVAL PRIOR TO INSTALLATION.
 - T/C TO INSTALL FIRE STOP IN ALL SLEEVES AND CONDUITS. INSTALL PER MANUFACTURERS LISTED UL SYSTEM.
 - CONDUITS THAT HAVE AN INTERNAL DIAMETER OF 2" OR LESS SHALL HAVE A BEND RADIUS OF AT LEAST 6 TIMES THE INTERNAL CONDUIT DIAMETER AND 10 TIMES THE INTERNAL DIAMETER FOR CONDUITS LARGER THAN 2".
 - MOUNT ALL CABLES WITH A D-RING OR OTHER ACCEPTABLE FASTENER. PROVIDE WIRE TIES EVENLY SPACED TO PROVIDE A CLEAN INSTALLATION.

1 COMMUNICATION OUTLET DETAIL

NOT TO SCALE

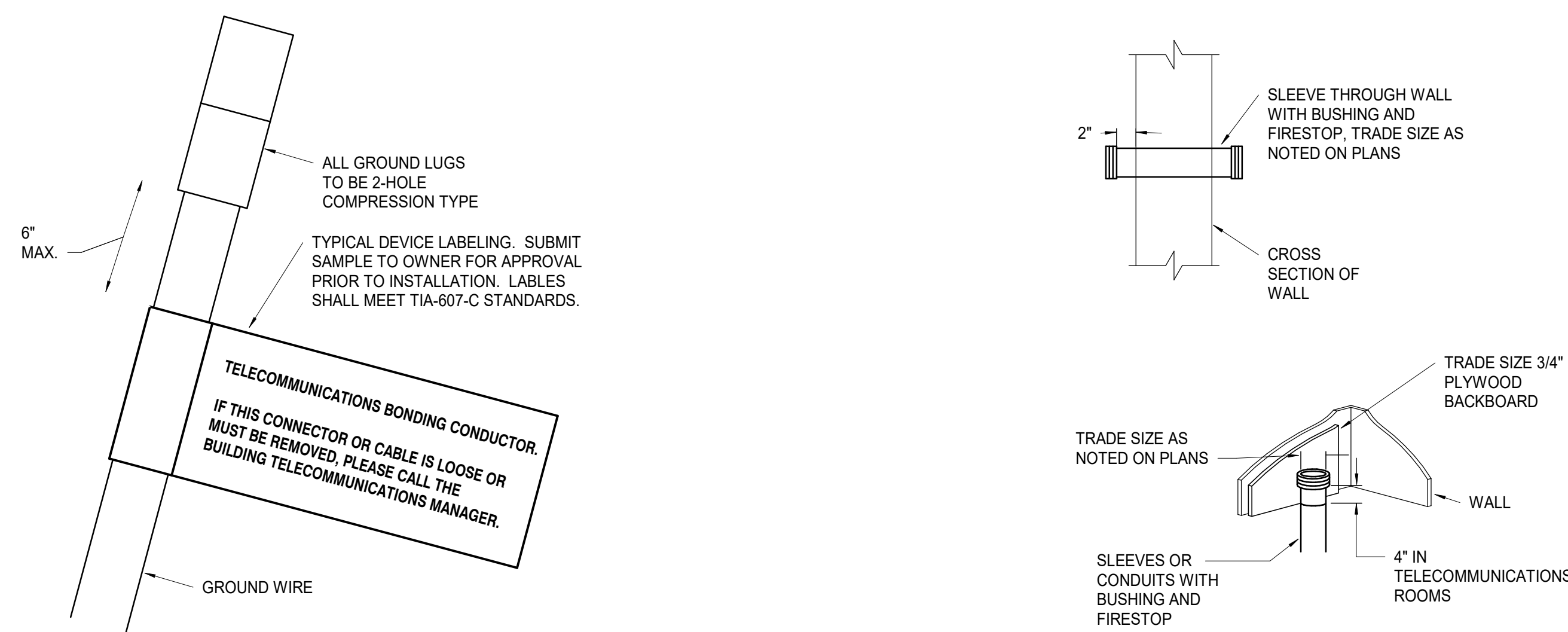

TELECOMMUNICATION CABLEING SCHEDULE									
MARK	DESCRIPTION	CABLE CONDUCTORS	MANUFACTURER	MODEL NUMBER	NOMINAL O.D.	JACKET COLOR	REMARKS	PROVIDED BY	INSTALLED BY
[1]	CATEGORY 6 COPPER CABLE (CMP)	4 PAIR	SUPERIOR ESSEX	66-240-2B	0.22"	BLUE		T/C	T/C
[2]	1 FT CATEGORY 6 PATCH CABLE (DATA)	4 PAIR	ORTRONICS	OR-MC601-06		BLUE	PROVIDE 250	T/C	T/C
[3]	5 FT CATEGORY 6 PATCH CABLE (DATA)	4 PAIR	ORTRONICS	OR-MC605-06		BLUE	PROVIDE 45	T/C	T/C
[4]	7 FT CATEGORY 6 PATCH CABLE (DATA)	4 PAIR	ORTRONICS	OR-MC607-06		BLUE	PROVIDE 150	T/C	T/C
[5]	9 FT CATEGORY 6 PATCH CABLE (DATA)	4 PAIR	ORTRONICS	OR-MC609-06		BLUE	PROVIDE 45	T/C	T/C
[6]	15 FT CATEGORY 6 PATCH CABLE (DATA)	4 PAIR	ORTRONICS	OR-MC615-06		BLUE	PROVIDE 15	T/C	T/C

REMARKS:
1 - USE OSP-RATED CABLING FOR VOICE/DATA OUTLETS THAT PASS BELOW GRADE

2 GROUND WIRE DETAIL

NOT TO SCALE

3 SLEEVE/CONDUIT DETAIL

NOT TO SCALE

TELECOMMUNICATIONS HARDWARE SCHEDULE							
MARK	MANUFACTURER	MODEL/PART NUMBER	PROVIDED BY	INSTALLED BY	DESCRIPTION	REMARKS	
[1]	CABLOFIL	SIZE AS NOTED ON PLANS	E/C	E/C	WIRE BASKET	3	
[2]	ORTRONICS	OR-40300158	T/C	T/C	SINGLE GANG SERIES II FACEPLATE (FOG WHITE)		
[3]	ORTRONICS	OR-S22600	T/C	T/C	CATEGORY 6 T568 A/B SERIES II MODULE	2	
[4]	ORTRONICS	OR-40300144	T/C	T/C	SERIES II BLANK (BLACK BLANKS IN POKE-THRU'S)		
[5]	ORTRONICS	OR-40300100	T/C	T/C	VOICE COLOR CODED TABS - BLACK		
[6]	ORTRONICS	OR-40326200	T/C	T/C	DATA COLOR CODED TABS - BLUE		
[7]	ORTRONICS	OR-PHD66U48	T/C	T/C	48 PORT CATEGORY 6 PATCH PANEL	2	
[8]	BY OWNER	BY OWNER	OWNER	OWNER	48-PORT POE GIGABIT SWITCH	1	
[9]	BY OWNER	BY OWNER	OWNER	T/C	WIRELESS ACCESS DEVICE	1	

REMARKS:
1 - ITEM SHALL BE FURNISHED BY OWNER AND INSTALLED BY CONTRACTOR. COORDINATE LABELING REQUIREMENTS WITH OWNER.
2 - WIRE CABLING T568B
3 - PROVIDE CABLE DROP-OUTS AS REQUIRED.

ACCESS CONTROL HARDWARE SCHEDULE				
MARK	MANUFACTURER	MODEL/PART NUMBER	DESCRIPTION	REMARKS
[10]	BELDEN	538AFS	ACCESS CONTROL CABLE	1
[11]	BELDEN	5302FE	ACCESS CONTROL CABLE	1
[12]	HOFFMAN	AH24N24	HOFFMAN ACCESS CONTROL ENCLOSURE (24"x24" NEMA 1)	1, 3
[13]	HID	RMPK40 (925PTNTEK0002L)	MULTICLASS MAGNETIC CARD SWIPE READER	1
[14]	ALTRONIX	AL1024LXP16	POWER SUPPLY FOR ACCESS CONTROL PANEL (24V, OUTPUTS)	1, 4
[15]	ALTRONIX	AL1012LXP16	POWER SUPPLY FOR ACCESS CONTROL PANEL (12V, OUTPUTS)	1, 4
[16]	N/A	N/A	DOOR POSITION SWITCH	2
[17]	N/A	N/A	REQUEST TO EXIT DETECTOR	2
[18]	N/A	N/A	POWER SUPPLY (24V DC)	2

REMARKS:
1 - PROVIDED AND INSTALLED BY CBS.
2 - PROVIDED AS A PART OF THE DOOR HARDWARE PACKAGE.
3 - PROVIDE EXISTING PANEL WITH DOOR READER INTERFACE (PERSONA/HID MODEL #100).
4 - POWER SUPPLY SHALL BE LOCATED IN TELECOM ROOM.

SECURITY HARDWARE SCHEDULE				
MARK	MANUFACTURER	MODEL/PART NUMBER	DESCRIPTION	REMARKS
[19]	AVIGILON	4.0C-H6X-D01-IR	4MP INDOOR IR DOME, 4.4-9.3MM	1

REMARKS:
1. CONTRACTOR SHALL PROVIDE LICENSING AND PROGRAM INTO OWNER'S EXISTING VIDEO SURVEILLANCE SYSTEM. PROVIDE WITH IN-CEILING MOUNT, MODEL #CLADP-1001.

CABLE LEGEND:		ACCESS CONTROL DEVICE LEGEND:	
[19A]	PROXIMITY CARD READER (ORANGE) 18GA. 4 COND. TWISTED OVERALL SHIELD, RISER RATED CABLE.	[ACP]	ACCESS CONTROL PANEL
[19B]	MAGNETIC SWITCH (WHITE) 18GA. 4 COND. TWISTED OVERALL SHIELD, RISER RATED CABLE.	[CR]	HID CARD READER
[19C]	ELECTRIC LOCK (GRAY) 18GA. 4 COND. TWISTED OVERALL SHIELD, RISER RATED CABLE.	[REX]	REQUEST TO EXIT *
[19D]	REQUEST TO EXIT (BLUE) 18GA. 4 COND. TWISTED OVERALL SHIELD, RISER RATED CABLE.	[DP]	DOOR POSITION SWITCH *
[19E]	ELECTRIC LOCK FROM PS TO PUSHBAR 18GA. 4 COND. TWISTED OVERALL SHIELD, RISER RATED CABLE.	[EL]	ELECTRIC LOCK (24V, DC) *
[19F]	ELECTRIC LOCK FROM PS TO PUSHBAR 18GA. 4 COND. TWISTED OVERALL SHIELD, RISER RATED CABLE.	[PS]	POWER SUPPLY (24V, DC) *
[19G]	ELECTRIC LOCK FROM PS TO PUSHBAR 18GA. 4 COND. TWISTED OVERALL SHIELD, RISER RATED CABLE.	[ADA]	ADA PUSHBUTTON *
[19H]	ELECTRIC LOCK FROM PS TO PUSHBAR 18GA. 4 COND. TWISTED OVERALL SHIELD, RISER RATED CABLE.	[ADA]	DUAL ADA PUSHBUTTON *
[19I]	ELECTRIC LOCK FROM PS TO PUSHBAR 18GA. 4 COND. TWISTED OVERALL SHIELD, RISER RATED CABLE.	[ADM]	ADA MOTORIZED OPERATOR *
[19J]	ELECTRIC LOCK FROM PS TO PUSHBAR 18GA. 4 COND. TWISTED OVERALL SHIELD, RISER RATED CABLE.	[VMS]	VIDEO INTERCOM MASTER STATION
[19K]	ELECTRIC LOCK FROM PS TO PUSHBAR 18GA. 4 COND. TWISTED OVERALL SHIELD, RISER RATED CABLE.	[VIC]	VIDEO INTERCOM

* - INDICATES PROVIDED BY DOOR HARDWARE SUPPLIER. REFER TO DOOR HARDWARE SPECIFICATIONS FOR FURTHER WIRING, POWER, AND PROGRAMMING REQUIREMENTS.

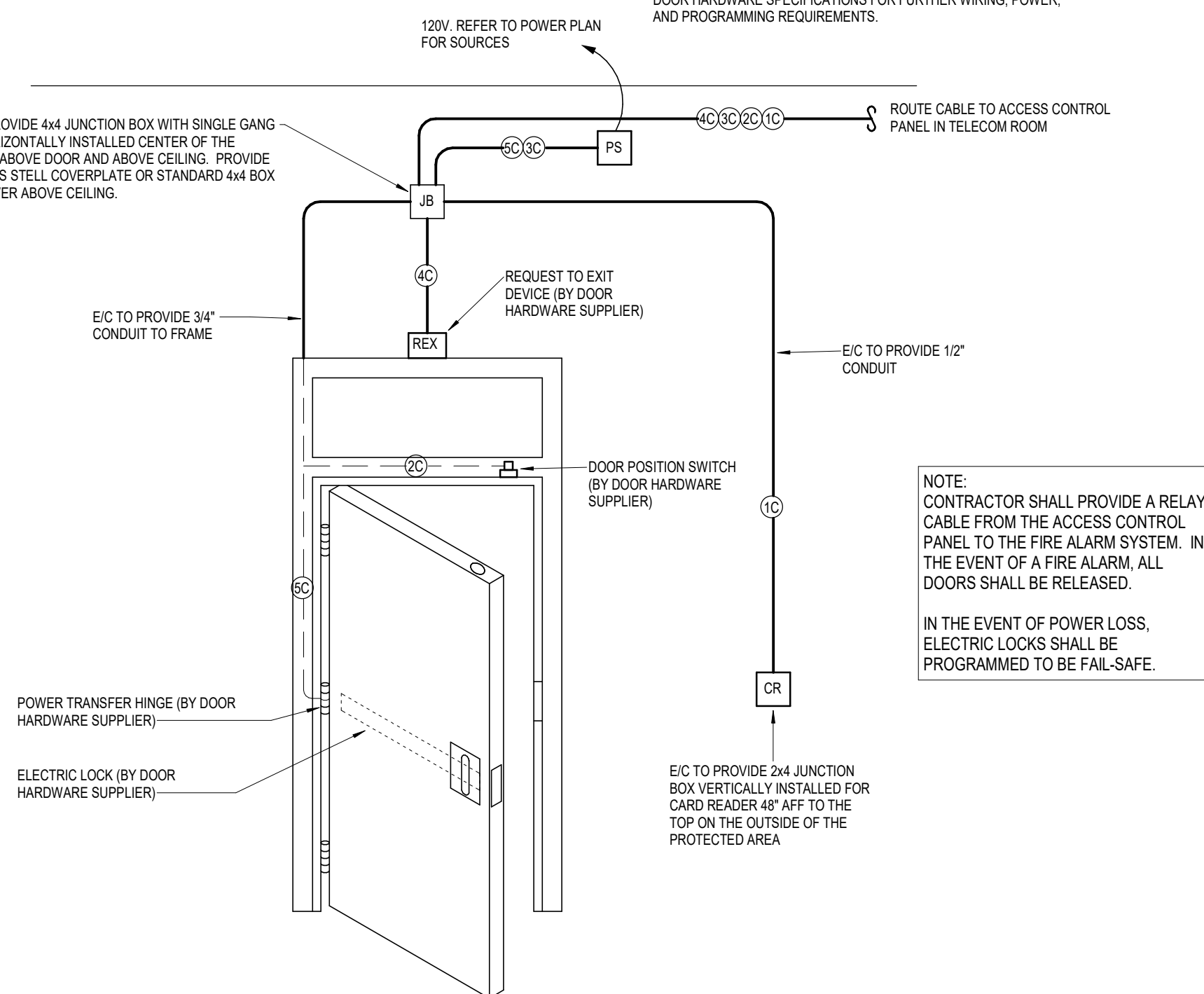

4 TYPICAL ACCESS DOOR DETAIL

NOT TO SCALE



7/16/2024

DATE:
July 15, 2024

REVISED DATE:

SHEET CONTENTS:
TELECOM DETAILS

HTK PROJECT NUMBER:
2312.03

SHEET NUMBER:

T201

ORIGINAL CONTRACT DOCUMENTS